

**ATTACHMENT N**  
**VOLATILE ORGANIC COMPOUND MONITORING PLAN**

Waste Isolation Pilot Plant  
Hazardous Waste Permit  
July 2, 2010

(This page intentionally blank)

## ATTACHMENT N

### VOLATILE ORGANIC COMPOUND MONITORING PLAN

#### TABLE OF CONTENTS

N-1	Introduction .....	1
N-1a	Background .....	1
N-1b	Objectives of the Volatile Organic Compound Monitoring Plan.....	2
N-2	Target Volatile Organic Compounds .....	2
N-3	Monitoring Design .....	2
N-3a	Sampling Locations .....	2
N-3a(1)	Sampling Locations for Repository VOC Monitoring .....	3
N-3a(2)	Sampling Locations for Disposal Room VOC Monitoring .....	3
N-3a(3)	Ongoing Disposal Room VOC Monitoring in Panels 3 through 7 .....	4
N-3b	Analytes to Be Monitored .....	4
N-3c	Sampling and Analysis Methods .....	4
N-3d	Sampling Schedule .....	5
N-3d(1)	Sampling Schedule for Repository VOC Monitoring .....	5
N-3d(2)	Sampling Schedule for Disposal Room VOC Monitoring.....	6
N-3e	Data Evaluation and Reporting .....	6
N-3e(1)	Data Evaluation and Reporting for Repository VOC Monitoring.....	6
N-3e(2)	Data Evaluation and Reporting for Disposal Room VOC Monitoring.....	7
N-4	Sampling and Analysis Procedures .....	8
N-4a	Sampling Equipment .....	8
N-4a(1)	SUMMA <sup>®</sup> Canisters .....	8
N-4a(2)	Volatile Organic Compound Canister Samplers .....	8
N-4a(3)	Sample Tubing.....	9
N-4b	Sample Collection .....	9
N-4c	Sample Management .....	9
N-4d	Sampler Maintenance .....	10
N-4e	Analytical Procedures.....	10
N-5	Quality Assurance .....	11
N-5a	Quality Assurance Objectives for the Measurement of Precision, Accuracy, Sensitivity, and Completeness .....	11
N-5a(1)	Evaluation of Laboratory Precision .....	12
N-5a(2)	Evaluation of Field Precision .....	12
N-5a(3)	Evaluation of Laboratory Accuracy .....	12
N-5a(4)	Evaluation of Sensitivity.....	13
N-5a(5)	Completeness.....	13
N-5b	Sample Handling and Custody Procedures.....	13
N-5c	Calibration Procedures and Frequency .....	13
N-5d	Data Reduction, Validation, and Reporting .....	13
N-5e	Performance and System Audits .....	14
N-5f	Preventive Maintenance .....	14
N-5g	Corrective Actions .....	14

N-5h	Records Management .....	15
N-6	Sampling and Analysis Procedures for Disposal Room VOC Monitoring in Filled Panels .....	15
N-7	References .....	16

### LIST OF TABLES

<b>Table</b>	<b>Title</b>
Table N-1	Target Analytes and Methods for Repository VOC (Station VOC-A and VOC-B) Monitoring and Disposal Room Monitoring
Table N-2	Quality Assurance Objectives for Accuracy, Precision, Sensitivity, and Completeness

### LIST OF FIGURES

<b>Figure</b>	<b>Title</b>
Figure N-1	Panel Area Flow
Figure N-2	VOC Monitoring System Design
Figure N-3	Disposal Room VOC Monitoring
Figure N-4	VOC Sample Head Arrangement

## ACRONYMS AND ABBREVIATIONS

BS/BSD	blank spike/blank spike duplicate
CH	Contact-handled
CLP	Contract Laboratory Program
COC	concentration of concern
CRQL	contract-required quantitation limit
DOE	U.S. Department of Energy
EPA	U.S. Environmental Protection Agency
ft	feet
GC/MS	gas chromatography/mass spectrometry
HWDU	Hazardous Waste Disposal Unit
LCS	laboratory control sample
m	meter
MDL	method detection limit
MOC	Management and Operating Contractor (Permit Condition I.D.3)
MRL	method reporting limit
NIST	National Institute of Standards and Testing
ppbv	parts per billion by volume
QA	quality assurance
QAPD	Quality Assurance Program Description
QC	quality control
RCRA	Resource Conservation and Recovery Act
RPD	relative percent difference
SOP	standard operating procedure
TIC	tentatively identified compound
TRU	Transuranic
VOC	volatile organic compound
WIPP	Waste Isolation Pilot Plant

1 **ATTACHMENT N**

2 **VOLATILE ORGANIC COMPOUND MONITORING PLAN**

3 N-1 Introduction

4 This Permit Attachment describes the monitoring plan for volatile organic compound (**VOC**)  
5 emissions from mixed waste that may be entrained in the exhaust air from the U.S. Department  
6 of Energy (**DOE**) Waste Isolation Pilot Plant (**WIPP**) Underground Hazardous Waste Disposal  
7 Units (**HWDUs**) during the disposal phase at the facility. The purpose of VOC monitoring is to  
8 ensure compliance with the VOC limits specified in Permit Module IV. This VOC monitoring plan  
9 consists of two programs as follows; (1) Repository VOC Monitoring, which assesses  
10 compliance with the environmental performance standards in Table IV.F.2.c; and (2) Disposal  
11 Room VOC Monitoring, which assesses compliance with the disposal room performance  
12 standards in Table IV.F.3.b. This plan includes the monitoring design, a description of sampling  
13 and analysis procedures, quality assurance (**QA**) objectives, and reporting activities.

14 N-1a Background

15 The Underground HWDUs are located 2,150 feet (ft) (655 meters [m]) below ground surface, in  
16 the WIPP underground. As defined for this Permit, an Underground HWDU is a single  
17 excavated panel consisting of seven rooms and two access drifts designated for disposal of  
18 contact-handled (**CH**) and remote-handled (**RH**) transuranic (**TRU**) mixed waste. Each room is  
19 approximately 300 ft (91 m) long, 33 ft (10 m) wide, and 13 ft (4 m) high. Access drifts connect  
20 the rooms and have the same cross section. The Permittees shall dispose of TRU mixed waste  
21 in Underground HWDUs designated as Panels 1 through 7.

22 This plan addresses the following elements:

23 1. Rationale for the design of the VOC monitoring programs, based on:

- 24
- Possible pathways from WIPP during the active life of the facility
  - 25 • Demonstrating compliance with the disposal room performance standards by
  - 26 monitoring VOCs in underground disposal rooms
  - 27 • VOC sampling operations at WIPP
  - 28 • Optimum location of the ambient mine air monitoring stations

29 2. Descriptions of the specific elements of the VOC monitoring programs, including:

- 30
- The type of monitoring conducted
  - 31 • The location of the monitoring stations
  - 32 • The monitoring interval
  - 33 • The specific hazardous constituents monitored
  - 34 • The implementation schedule for the VOC monitoring programs
  - 35 • The equipment used at the monitoring stations
  - 36 • Sampling and analytical techniques used

- 1 • Data recording/reporting procedures
- 2 • Action levels for remedial action if limits are approached

3 The results of baseline VOC monitoring at WIPP were used, in part, to define the VOC  
4 monitoring programs. The baseline VOC monitoring results were presented in Appendix D21 of  
5 the WIPP Resource Conservation Recovery Act (**RCRA**) Part B Permit Application (DOE,  
6 1997). These data represent the anticipated background levels of VOCs during operations at  
7 WIPP. The technical basis for Disposal Room VOC Monitoring is discussed in detail in the  
8 Technical Evaluation Report for Room-Based VOC Monitoring (WRES, 2003).

#### 9 N-1b Objectives of the Volatile Organic Compound Monitoring Plan

10 The CH and RH TRU mixed waste disposed in the WIPP Underground HWDUs contain VOCs  
11 which could be released from WIPP during the disposal phase of the project. This plan  
12 describes how:

- 13 • VOCs released from waste panels will be monitored to confirm that the annual average  
14 concentration of VOCs in the air emissions from the Underground HWDUs do not  
15 exceed the VOC concentrations of concern (**COC**) identified in Permit Module IV,  
16 Table IV.F.2.c. Appropriate remedial action, as specified in Permit Condition IV.F.2.d,  
17 will be taken if the limits in Permit Module IV, Table IV.F.2.c are reached.
- 18 • VOCs released from waste containers in disposal rooms will be monitored to confirm  
19 that the concentration of VOCs in the air of closed and active rooms in active panels  
20 do not exceed the VOC disposal room limits identified in Permit Module IV, Table  
21 IV.D.1. Appropriate remedial action, as specified in Permit Condition IV.F.3.c, will be  
22 taken if the Action Levels in Permit Module IV, Table IV.F.3.b are reached.

#### 23 N-2 Target Volatile Organic Compounds

24 The target VOCs for repository monitoring (Station VOC-A and VOC-B) and disposal room  
25 monitoring presented in Table N-1.

26 These target VOCs were selected because together they represent approximately 99 percent of  
27 the risk due to air emissions.

#### 28 N-3 Monitoring Design

29 Detailed design features of this plan are presented in this section. This plan uses available  
30 sampling and analysis techniques to measure VOC concentrations in air. Sampling equipment  
31 includes the WIPP VOC canister samplers both the Repository and Disposal Room VOC  
32 Monitoring Programs.

#### 33 N-3a Sampling Locations

34 Air samples will be collected in the underground to quantify airborne VOC concentrations as  
35 described in the following sections.



1 N-3a(1) Sampling Locations for Repository VOC Monitoring

2 The initial configuration for the repository VOC monitoring stations is shown in Figure N-1. All  
3 mine ventilation air which could potentially be impacted by VOC emissions from the  
4 Underground HWDUs identified as Panels 1 through 7 will pass monitoring Station VOC-A,  
5 located in the E-300 drift as it flows to the exhaust shaft. Air samples will be collected at two  
6 locations in the facility to quantify airborne VOC concentrations. VOC concentrations attributable  
7 to VOC emissions from open and closed panels containing CH TRU mixed waste will be  
8 measured by placing one VOC monitoring station just downstream from Panel 1 at VOC-A. The  
9 location of Station VOC-A will remain the same throughout the term of this Permit. The second  
10 station (Station VOC-B) will always be located upstream from the open panel being filled with  
11 waste (starting with Panel 1 at monitoring Station VOC-B (Figure N-1). In this configuration,  
12 Station VOC-B will measure VOC concentrations attributable to releases from the upstream  
13 sources and other background sources of VOCs, but not releases attributable to open or closed  
14 panels. The location of Station VOC-B will change when disposal activities begin in the next  
15 panel. Station VOC-B will be relocated to ensure that it is always upstream of the open panel  
16 that is receiving TRU mixed waste. Station VOC-A will also measure upstream VOC  
17 concentrations measured at Station VOC-B, plus any additional VOC concentrations resulting  
18 from releases from the closed and open panels. A sample will be collected from each monitoring  
19 station on designated sample days. For each quantified target VOC, the concentration  
20 measured at Station VOC-B will be subtracted from the concentration measured at Station  
21 VOC-A to assess the magnitude of VOC releases from closed and open panels.

22 The sampling locations were selected based on operational considerations. There are several  
23 different potential sources of release for VOCs into the WIPP mine ventilation air. These  
24 sources include incoming air from above ground and facility support operations, as well as open  
25 and closed waste panels. In addition, because of the ventilation requirements of the  
26 underground facility and atmospheric dispersion characteristics, any VOCs that are released  
27 open or closed panels may be difficult to detect and differentiate from other sources of VOCs at  
28 any underground or above ground location further downstream of Panel 1. By measuring VOC  
29 concentrations close to the potential source of release (i.e., at Station VOC-A), it will be possible  
30 to differentiate potential releases from background levels (measured at Station VOC-B).

31 N-3a(2) Sampling Locations for Disposal Room VOC Monitoring

32 For purposes of compliance with Section 310 of Public Law 108-447, the VOC monitoring of  
33 airborne VOCs in underground disposal rooms in which waste has been emplaced will be  
34 performed as follows:

- 35 1. A sample head will be installed inside the disposal room behind the exhaust drift  
36 bulkhead and at the inlet side of the disposal room.
- 37 2. TRU mixed waste will be emplaced in the active disposal room.
- 38 3. When the active disposal room is filled, another sample head will be installed to the  
39 inlet of the filled active disposal room. (Figure N-3 and N-4)
- 40 4. The exhaust drift bulkhead will be removed and re-installed in the next disposal room  
41 so disposal activities may proceed.

- 1           5. A ventilation barrier will be installed where the bulkhead was located in the active  
2           disposal room's exhaust drift. Another ventilation barrier will be installed in the active  
3           disposal room's air inlet drift, thereby closing that active disposal room.
- 4           6. Monitoring of VOCs will continue in the now closed disposal room. Monitoring of VOCs  
5           will occur in the active disposal room and all closed disposal rooms in which waste has  
6           been emplaced until commencement of panel closure activities (i.e., completion of  
7           ventilation barriers in Room 1).

8           This sequence for installing sample locations will proceed in the remaining disposal rooms until  
9           the inlet air ventilation barrier is installed in disposal room one. An inlet sampler will not be  
10          installed in disposal room one because disposal room sampling proceeds to the next panel.

11          N-3a(3) Ongoing Disposal Room VOC Monitoring in Panels 3 through 7

12          The Permittees shall continue VOC monitoring in Room 1 of Panels 3 through 7 after  
13          completion of waste emplacement until final panel closure unless an explosion-isolation wall is  
14          installed in the panel.

15          N-3b Analytes to Be Monitored

16          The nine VOCs that have been identified for repository and disposal room monitoring are listed  
17          in Table N-1. The analysis will focus on routine detection and quantification of these compounds  
18          in collected samples. As part of the analytical evaluations, the presence of other compounds will  
19          be investigated. The analytical laboratory will be directed to classify and report all of these  
20          compounds as Tentatively Identified Compounds (**TICs**).

21          TICs detected in 10% or more of any VOC monitoring samples (exclusive of those collected  
22          from Station VOC-B) that are VOCs listed in Appendix VIII of 20.4.1.200 NMAC (incorporating  
23          40 CFR §261), collected over a running twelve-month timeframe, will be added to the target  
24          analyte lists for both the repository and disposal room VOC monitoring programs, unless the  
25          Permittees can justify the exclusion from the target analyte list(s).

26          TICs detected in the repository and disposal room VOC monitoring programs will be placed in  
27          the WIPP Operating Record and reported to NMED in the Semi-Annual VOC Monitoring Report  
28          as specified in Permit Condition IV.F.2.b.

29          N-3c Sampling and Analysis Methods

30          The VOC monitoring programs include a comprehensive VOC monitoring program established  
31          at the facility; equipment, training, and documentation for VOC measurements are already in  
32          place.

33          The method used for VOC sampling is based on the concept of pressurized sample collection  
34          contained in the U.S. Environmental Protection Agency (**EPA**) Compendium Method TO-15  
35          (EPA, 1999). The TO-15 sampling concept uses 6-liter SUMMA<sup>®</sup> passivated (or equivalent)  
36          stainless-steel canisters to collect integrated air samples at each sample location. This  
37          conceptual method will be used as a reference for collecting the samples at WIPP. The samples  
38          will be analyzed using gas chromatography/mass spectrometry (**GC/MS**) under an established  
39          QA/quality control (**QC**) program. Laboratory analytical procedures have been developed based

1 on the concepts contained in both TO-15 and 8260B. Section N-5 contains additional QA/QC  
2 information for this project.

3 The TO-15 method is an EPA-recognized sampling concept for VOC sampling and speciation. It  
4 can be used to provide integrated samples, or grab samples, and compound quantitation for a  
5 broad range of concentrations. The sampling system can be operated unattended but requires  
6 detailed operator training. This sampling technique is viable for use while analyzing the sample  
7 using other EPA methods such as 8260B.

8 The field sampling systems will be operated in the pressurized mode. In this mode, air is drawn  
9 through the inlet and sampling system with a pump. The air is pumped into an initially evacuated  
10 SUMMA<sup>®</sup> passivated (or equivalent) canister by the sampler, which regulates the rate and  
11 duration of sampling. The treatment of tubing and canisters used for VOC sampling effectively  
12 seals the inner walls and prevents compounds from being retained on the surfaces of the  
13 equipment. By the end of each sampling period, the canisters will be pressurized to about two  
14 atmospheres absolute. In the event of shortened sampling periods or other sampling conditions,  
15 the final pressure in the canister may be less than two atmospheres absolute. Sampling  
16 duration will be approximately six hours, so that a complete sample can be collected during a  
17 single work shift.

18 The canister sampling system and GC/MS analytical method are particularly appropriate for the  
19 VOC Monitoring Programs because a relatively large sample volume is collected, and multiple  
20 dilutions and reanalyses can occur to ensure identification and quantification of target VOCs  
21 within the working range of the method. The contract-required quantitation limits (**CRQL**) are 5  
22 parts per billion by volume (**ppbv**) or less for the nine target compounds. Consequently, low  
23 concentrations can be measured. CRQLs are the EPA-specified levels of quantitation proposed  
24 for EPA contract laboratories that analyze canister samples by GC/MS. For the purpose of this  
25 plan, the CRQLs will be defined as the method reporting limits (**MRL**). The MRL is a function of  
26 instrument performance, sample preparation, sample dilution, and all steps involved in the  
27 sample analysis process.

28 Disposal room VOC monitoring system in open panels will employ the same canister sampling  
29 method as used in the repository VOC monitoring. Passivated or equivalent sampling lines will  
30 be installed in the disposal room as described in Section N-3a(2) and maintained once the room  
31 is closed until the panel associated with the room is closed. The independent lines will run from  
32 the sample inlet point to the individual sampler located in the access drift to the disposal panel.  
33 The air will pass through dual particulate filters to prevent sample and equipment contamination.

#### 34 N-3d Sampling Schedule

35 The Permittees will evaluate whether the monitoring systems and analytical methods are  
36 functioning properly. The assessment period will be determined by the Permittees.

#### 37 N-3d(1) Sampling Schedule for Repository VOC Monitoring

38 Repository VOC sampling at Stations VOC-A and VOC-B will begin with initial waste  
39 emplacement in Panel 1. Sampling will continue until the certified closure of the last  
40 Underground HWDU. Routine sampling will be conducted two times per week.

1 N-3d(2) Sampling Schedule for Disposal Room VOC Monitoring

2 The disposal room sampling in open panels will occur once every two weeks, unless the need to  
3 increase the frequency to weekly occurs in accordance with Permit Condition IV.F.3.c.

4 Beginning with Panel 3, disposal room sampling in filled panels will occur monthly until final  
5 panel closure unless an explosion-isolation wall is installed. The Permittees will sample VOCs in  
6 Room 1 of each filled panel.

7 N-3e Data Evaluation and Reporting

8 N-3e(1) Data Evaluation and Reporting for Repository VOC Monitoring

9 When the Permittees receive laboratory analytical data from an air sampling event, the data will  
10 be validated as specified in Section N-5d. After obtaining validated data from an air sampling  
11 event, the data will be evaluated to determine whether the VOC emissions from the  
12 Underground HWDUs exceed the COCs. The COCs for each of the nine target VOCs are  
13 presented in Permit Module IV, Table IV.F.2.c. The values are presented in terms of  
14 micrograms per cubic meter ( $\mu\text{g}/\text{m}^3$ ) and ppbv.

15 The COCs were calculated assuming typical operational conditions for ventilation rates in the  
16 mine. The typical operational conditions were assumed to be an overall mine ventilation rate of  
17 425,000 standard cubic feet per minute and a flow rate through the E-300 Drift at Station VOC-A  
18 of 130,000 standard cubic feet per minute.

19 Since the mine ventilation rates at the time the air samples are collected may be different than  
20 the mine ventilation rates during typical operational conditions, the Permittees will measure  
21 and/or record the overall mine ventilation rate and the ventilation rate in the E-300 Drift at  
22 Station VOC-A that are in use during each sampling event. The Permittees shall also measure  
23 and record temperature and pressure conditions during the sampling event to allow all  
24 ventilation rates to be converted to standard flow rates.

25 If the air samples were collected under the typical mine ventilation rate conditions, then the  
26 analytical data will be used without further manipulation. The concentration of each target VOC  
27 detected at Station VOC-B will be subtracted from the concentration detected at Station VOC-A.  
28 The resulting VOC concentration represents the concentration of VOCs being emitted from the  
29 open and closed Underground HWDUs upstream of Station VOC-A (or the Underground HWDU  
30 VOC emission concentration.)

31 If the air samples were not collected under typical mine ventilation rate operating conditions, the  
32 air monitoring analytical results from both Station VOC-A and Station VOC-B will be normalized  
33 to the typical operating conditions. This will be accomplished using the mine ventilation rates in  
34 use during the sampling event and the following equation:

35 
$$NVOC_{AB} = VOC_{AB} * \left( \frac{425,000_{scfm} / 130,000_{scfm}}{V_{O_{scfm}} / V_{E-300_{scfm}}} \right) \quad (N-1)$$

- 1 Where:  $NVOC_{AB}$  = Normalized target VOC concentration from Stations VOC-A or  
2 VOC-B
- 3  $VOC_{AB}$  = Concentration of the target VOC detected at Station VOC-A or  
4 VOC-B under non-typical mine ventilation rates
- 5 scfm = Standard cubic feet per minute
- 6  $V_o$  = Sampling event overall mine ventilation rate (in standard cubic feet  
7 per minute)
- 8  $VE-300$  = Sampling event mine ventilation rate through the E-300 Drift (in  
9 standard cubic feet per minute)

10 The normalized concentration of each target VOC detected at Station VOC-B will be subtracted  
11 from the normalized concentration detected at Station VOC-A. The resulting concentration  
12 represents the Underground HWDU VOC emission concentration.

13 The Underground HWDU VOC emission concentration for each target VOC that is calculated for  
14 each sampling event will be compared directly to its COC listed in Permit Module IV, Table  
15 IV.F.2.c. This will establish whether any of the concentrations of VOCs in the emissions from the  
16 Underground HWDUs exceeded the COCs at the time of the sampling.

17 As specified in Permit Module IV, the Permittees shall notify the Secretary in writing, within  
18 seven(7) calendar days of obtaining validated analytical results, whenever the concentrations of  
19 any target VOC listed in exceeds the concentration of concern specified in Permit Module IV,  
20 Table IV.F.2.c.

21 The Underground HWDU VOC emission concentration for each target VOC that is calculated for  
22 each sampling event will then be averaged with the Underground HWDU VOC emission  
23 concentrations calculated for the air sampling events conducted during the previous 12 months.  
24 This will be considered the running annual average concentration for each target VOC. For the  
25 first year of air sampling, the running annual average concentration for each target VOC will be  
26 calculated using all of the previously collected data.

27 As specified in Permit Module IV, the Permittees shall notify the Secretary in writing, within  
28 seven (7) calendar days of obtaining validated analytical results, whenever the running annual  
29 average concentration (calculated after each sampling event) for any target VOC exceeds the  
30 concentration of concern specified in Permit Module IV, Table IV.F.2.c.

31 If the results obtained from an individual air sampling event do not trigger the notification  
32 requirements of Permit Module IV, then the Permittees will maintain a database with the VOC  
33 air sampling data and the results will be reported to the Secretary as specified in Permit  
34 Module IV.

### 35 N-3e(2) Data Evaluation and Reporting for Disposal Room VOC Monitoring

36 When the Permittees receive laboratory analytical data from an air sampling event, the data will  
37 be validated as specified in Section N-5a, within fourteen (14) calendar days of receiving the  
38 laboratory analytical data. After obtaining validated data from an air sampling event, the data will

1 be evaluated to determine whether the VOC concentrations in the air of any closed room, the  
2 active open room, or the immediately adjacent closed room exceeded the Action Levels for  
3 Disposal Room Monitoring specified in Permit Module IV, Table IV.F.3.b.

4 The Permittees shall notify the Secretary in writing, within seven (7) calendar days of obtaining  
5 validated analytical results, whenever the concentration of any VOC specified in Permit Module  
6 IV, Table IV.D.1 exceeds the action levels specified in Permit Module IV, Table IV.F.3.b.

7 The Permittees shall submit to the Secretary the Semi-Annual VOC Monitoring Report specified  
8 in Permit Condition IV.F.2.b that also includes results from disposal room VOC monitoring.

#### 9 N-4 Sampling and Analysis Procedures

10 This section describes the equipment and procedures that will be implemented during sample  
11 collection and analysis activities for VOCs at WIPP.

#### 12 N-4a Sampling Equipment

13 The sampling equipment that will be used includes the following: 6-liter (L) stainless-steel  
14 SUMMA<sup>®</sup> canisters, VOC canister samplers, treated stainless steel tubing, and a dual filter  
15 housing. A discussion of each of these items is presented below.

#### 16 N-4a(1) SUMMA<sup>®</sup> Canisters

17 Six-liter, stainless-steel canisters with SUMMA<sup>®</sup> passivated interior surfaces will be used to  
18 collect and store all ambient air and gas samples for VOC analyses collected as part of the  
19 monitoring processes. These canisters will be cleaned and certified prior to their use, in a  
20 manner similar to that described by Compendium Method TO-15. The canisters will be certified  
21 clean to below the required reporting limits for the VOC analytical method for the target VOCs  
22 (see Table N-2). The vacuum of certified clean samplers will be verified at the sampler upon  
23 initiation of a sample cycle.

#### 24 N-4a(2) Volatile Organic Compound Canister Samplers

25 A conceptual diagram of a VOC sample collection unit is provided in Figure N-2. Such units will  
26 be used at monitoring Stations VOC-A and VOC-B and at sampling locations for disposal room  
27 measurements. The sampling unit consists of a sample pump, flow controller, sample inlet, inlet  
28 filters in series to remove particulate matter, vacuum/pressure gauge, electronic timer, inlet  
29 purge vent, two sampling ports, and sufficient collection canisters so that any delays attributed  
30 to laboratory turnaround time and canister cleaning and certification will not result in canister  
31 shortages. Knowledge of sampler flow rates and duration of sampling will allow calculation of  
32 sample volume. The set point flow rate will be verified before and after sample collection from  
33 the mass flow indication. Prior to their initial use and annually thereafter, the sample collection  
34 units will be tested and certified to demonstrate that they are free of contamination above the  
35 reporting limits of the VOC analytical method (see Section N-5). Ultra-high purity humidified zero  
36 air will be pumped through the inlet line and sampling unit and collected in previously certified  
37 canisters as sampler blanks for analysis. The cleaning and certification procedure is derived  
38 from concepts contained in the EPA Compendium Method TO-15 (EPA, 1999).

1 N-4a(3) Sample Tubing

2 Treated stainless steel tubing is used as a sample path, from the desired sample point to the  
3 sample collection unit. This tubing is treated to prevent the inner walls from absorbing  
4 contaminants when they are pulled from the sample point to the sample collection unit.

5 N-4b Sample Collection

6 Six-hour integrated samples will be collected on each sample day. Alternative sampling  
7 durations may be defined for experimental purposes. The VOC canister sampler at each  
8 location will sample ambient air on the same programmed schedule. The sample pump will be  
9 programmed to sample continuously over a six-hour period during the workday. The units will  
10 sample at a nominal flow rate of 33.3 actual milliliters per minute over a six-hour sample period.  
11 This schedule will yield a final sample volume of approximately 12 L. Flow rates and sampling  
12 duration may be modified as necessary for experimental purposes and to meet the data quality  
13 objectives.

14 Sample flow will be checked each sample day using an in-line mass flow controller. The flow  
15 controllers are initially factory-calibrated and specify a typical accuracy of better than 10 percent  
16 full scale. Additionally, each air flow controller is calibrated at a manufacturer-specified  
17 frequency using a National Institute of Standards and Testing (NIST) primary flow standard.

18 Upon initiation of waste disposal activities in Panel 1, samples will be collected twice each week  
19 (at Stations VOC-A and VOC-B). Samples collected at the panel locations should represent the  
20 same matrix type (i.e., elevated levels of salt aerosols). To verify the matrix similarity and  
21 assess field sampling precision, field duplicate samples will be collected (two canisters filled  
22 simultaneously by the same sampler) from each sampling station (Stations VOC-A and VOC-B)  
23 during the first sampling event and at an overall frequency of 5 percent thereafter (see  
24 Section N-5a).

25 Prior to collecting the active open disposal room and closed room samples, the sample lines are  
26 purged to ensure that the air collected is not air that has been stagnant in the tubing. This is  
27 important in regard to the disposal room sample particularly because of the long lengths of  
28 tubing associated with these samples. The repository samples do not require this action due to  
29 the short lengths of tubing required at these locations.

30 N-4c Sample Management

31 Field sampling data sheets will be used to document the sampler conditions under which each  
32 sample is collected. These data sheets have been developed specifically for VOC monitoring at  
33 the WIPP facility. The individuals assigned to collect the specific samples will be required to fill  
34 in all of the appropriate sample data and to maintain this record in sample logbooks. The  
35 program team leader will review these forms for each sampling event.

36 All sample containers will be marked with identification at the time of collection of the sample. A  
37 Request-for-Analysis Form will be completed to identify the sample canister number(s), sample  
38 type and type of analysis requested.

39 All samples will be maintained, and shipped if necessary, at ambient temperatures. Collected  
40 samples will be transported in appropriate containers. Prior to leaving the underground for

1 analysis, sample containers may undergo radiological screening. No potentially contaminated  
2 samples or equipment will be transported to the surface. No samples will be accepted by the  
3 receiving laboratory personnel unless they are properly labeled and sealed to ensure a tamper  
4 free shipment.

5 An important component of the sampling program is a demonstration that collected samples  
6 were obtained from the locations stated and that they reached the laboratory without alteration.  
7 To satisfy this requirement, evidence of collection, shipment, laboratory receipt, and custody will  
8 be documented with a completed Chain-of-Custody Form. Chain-of-custody procedures will be  
9 followed closely, and additional requirements imposed by the laboratory for sample analysis will  
10 be included as necessary.

11 Individuals collecting samples will be responsible for the initiation of custody procedures. The  
12 chain of custody will include documentation as to the canister certification, location of sampling  
13 event, time, date, and individual handling the samples. Deviations from procedure will be  
14 considered variances. Variances must be preapproved by the program manager and recorded  
15 in the project files. Unintentional deviations, sampler malfunctions, and other problems are  
16 nonconformances. Nonconformances must be documented and recorded in the project files. All  
17 field logbooks/data sheets must be incorporated into WIPP's records management program.

#### 18 N-4d Sampler Maintenance

19 Periodic maintenance for canister samplers and associated equipment will be performed during  
20 each cleaning cycle. This maintenance will include, but not be limited to, replacement of  
21 damaged or malfunctioning parts without compromising the integrity of the sampler, leak testing,  
22 and instrument calibration. Additionally, complete spare units will be maintained on-site to  
23 minimize downtime because of sampler malfunction. At a minimum, canister samplers will be  
24 certified for cleanliness initially and annually thereafter upon initial use, after any parts that are  
25 included in the sample flow path are replaced, or any time analytical results indicate potential  
26 contamination. All sample canisters will be certified prior to each usage.

#### 27 N-4e Analytical Procedures

28 Analytical procedures used in the analysis of VOC samples from canisters are based on  
29 concepts contained in Compendium Method TO-15 (EPA, 1999) and in SW-846 Method 8260B  
30 (EPA, 1996).

31 Analysis of samples will be performed by a certified laboratory. Methods will be specified in  
32 procurement documents and will be selected to be consistent with Compendium Method TO-15  
33 (EPA, 1999) or EPA recommended procedures in SW-846 (EPA, 1996). Additional detail on  
34 analytical techniques and methods will be given in laboratory SOPs.

35 The Permittees will establish the criteria for laboratory selection, including the stipulation that  
36 the laboratory follow the procedures specified in the appropriate Air Compendium or SW-846  
37 method and that the laboratory follow EPA protocols. The selected laboratory shall demonstrate,  
38 through laboratory SOPs, that it will follow appropriate EPA SW-846 requirements and the  
39 requirements specified by the EPA Air Compendium protocols. The laboratory shall also provide  
40 documentation to the Permittees describing the sensitivity of laboratory instrumentation. This  
41 documentation will be retained in the facility operating record and will be available for review  
42 upon request by NMED.



1 The SOPs for the laboratory currently under contract will be maintained in the operating record  
2 by the Permittees. The Permittees will provide NMED with an initial set of applicable laboratory  
3 SOPs for information purposes, and provide NMED with any updated SOPs on an annual basis.

4 Data validation will be performed by the Permittees. Copies of the data validation report will be  
5 kept on file in the operating record for review upon request by NMED.

#### 6 N-5 Quality Assurance

7 The QA activities for the VOC monitoring programs will be conducted in accordance with the  
8 documents: *EPA Guidance for Quality Assurance Project Plans QA/G-5* (EPA, 2002) and the  
9 *EPA Requirements for Preparing Quality Assurance Project Plans, QA/R-5* (EPA, 2001). The  
10 QA criteria for the VOC monitoring programs are listed in Table N-2. This section addresses the  
11 methods to be used to evaluate the components of the measurement system and how this  
12 evaluation will be used to assess data quality. The QA limits for the sampling procedures and  
13 laboratory analysis shall be in accordance with the limits set forth in the specific EPA Method  
14 referenced in standard operating procedures employed by either the Permittees or the  
15 laboratory. The Permittees standard operating procedures will be in the facility Operating  
16 Record and available for review by NMED at anytime. The laboratory standard operating  
17 procedures will also be in the facility Operating Record and will be supplied to the NMED as  
18 indicated in Section N-4e.

#### 19 N-5a Quality Assurance Objectives for the Measurement of Precision, Accuracy, Sensitivity, 20 and Completeness

21 QA objectives for this plan will be defined in terms of the following data quality parameters.

22 **Precision.** For the duration of this program, precision will be defined and evaluated by the RPD  
23 values calculated between field duplicate samples and between laboratory duplicate samples.

$$24 \quad RPD = \left( \frac{(A - B)}{(A + B)/2} \right) * 100 \quad (N-2)$$

25 where: A = Original sample result

26 B = Duplicate sample result

27 **Accuracy.** Analytical accuracy will be defined and evaluated through the use of analytical  
28 standards. Because recovery standards cannot reliably be added to the sampling stream,  
29 overall system accuracy will be based on analytical instrument performance evaluation criteria.  
30 These criteria will include performance verification for instrument calibrations, laboratory control  
31 samples, sample surrogate recoveries (when required by method or laboratory SOPs), and  
32 sample internal standard areas. Use of the appropriate criteria as determined by the analytical  
33 method performed, will constitute the verification of accuracy for target analyte quantitation  
34 (i.e., quantitative accuracy). Evaluation of standard ion abundance criteria for BFB will be used  
35 to evaluate the accuracy of the analytical system in the identification of targeted analytes, as  
36 well as the evaluation of unknown contaminants (i.e., qualitative accuracy).

1 **Sensitivity.** Sensitivity will be defined by the required MRLs for the program. Attainment of  
2 required MRLs will be verified by the performance of statistical method detection limit (**MDL**)  
3 studies in accordance with 40 *Code of Federal Regulations* § 136. The MDL represents the  
4 minimum concentration that can be measured and reported with 99 percent confidence that the  
5 analyte concentration is greater than zero. An MDL study will be performed by the program  
6 analytical laboratory prior to sampling and analysis, and annually thereafter.

7 **Completeness.** Completeness will be defined as the percentage of the ratio of the number of  
8 valid sample results received (i.e., those which meet data quality objectives) versus the total  
9 number of samples collected. Completeness may be affected, for example, by sample loss or  
10 destruction during shipping, by laboratory sample handling errors, or by rejection of analytical  
11 data during data validation.

#### 12 N-5a(1) Evaluation of Laboratory Precision

13 Laboratory sample duplicates and blank spike/blank spike duplicates (**BS/BSD**) will be used to  
14 evaluate laboratory precision. QA objectives for laboratory precision are listed in Table N-2, and  
15 are based on precision criteria proposed by the EPA for canister sampling programs (EPA,  
16 1994). These values will be appropriate for the evaluation of samples with little or no matrix  
17 effects. Because of the potentially high level of salt-type aerosols in the WIPP underground  
18 environment, the analytical precision achieved for WIPP samples may vary with respect to the  
19 EPA criteria. RPDs for BS/BSD analyses will be tracked through the use of control charts. RPDs  
20 obtained for laboratory sample duplicates will be compared to those obtained for BS/BSDs to  
21 ascertain any sample matrix effects on analytical precision. BS/BSDs and laboratory sample  
22 duplicates will be analyzed at a frequency of 10 percent, or one per analytical lot, whichever is  
23 more frequent.

#### 24 N-5a(2) Evaluation of Field Precision

25 Field duplicate samples will be collected at a frequency of 5 percent for both monitoring  
26 locations. The data quality objective for field precision is 35 percent for each set of duplicate  
27 samples.

#### 28 N-5a(3) Evaluation of Laboratory Accuracy

29 Quantitative analytical accuracy will be evaluated through performance criteria on the basis of  
30 (1) relative response factors generated during instrument calibration, (2) analysis of laboratory  
31 control samples (**LCS**), and (3) recovery of internal standard compounds. The criteria for the  
32 initial calibration (5-point calibration) is  $\leq 30$  percent relative standard deviation for target  
33 analytes. After the successful completion of the 5-point calibration, it is sufficient to analyze only  
34 a midpoint standard for every 24 hours of operation. The midpoint standard will pass a 30  
35 percent difference acceptance criterion for each target compound before sample analysis may  
36 begin.

37 A blank spike or LCS is an internal QC sample generated by the analytical laboratory by spiking  
38 a standard air matrix (humid zero air) with a known amount of a certified reference gas. The  
39 reference gas will contain the target VOCs at known concentrations. Percent recoveries for the  
40 target VOCs will be calculated for each LCS relative to the reference concentrations. Objectives  
41 for percent recovery are listed in Table N-2, and are based on accuracy criteria proposed by the

1 EPA for canister sampling programs (EPA, 1994). LCSs will be analyzed at a frequency of 10  
2 percent, or one per analytical lot, whichever is more frequent.

3 Internal standards will be introduced into each sample analyzed, and will be monitored as a  
4 verification of stable instrument performance. In the absence of any unusual interferences,  
5 areas should not change by more than 40 percent over a 24-hour period. Deviations larger than  
6 40 percent are an indication of a potential instrument malfunction. If an internal standard area in  
7 a given sample changes by more than 40 percent, the sample will be reanalyzed. If the 40  
8 percent criterion is not achieved during the reanalysis, the instrument will undergo a  
9 performance check and the midpoint standard will be reanalyzed to verify proper operation.  
10 Response and recovery of internal standards will also be compared between samples, LCSs,  
11 and calibration standards to identify any matrix effects on analytical accuracy.

#### 12 N-5a(4) Evaluation of Sensitivity

13 The presence of aerosol salts in underground locations may affect the MDL of the samples  
14 collected in those areas. The intake manifold of the sampling systems will be protected  
15 sufficiently from the underground environment to minimize salt aerosol interference.

16 The MDL for each of the nine target compounds will be evaluated by the analytical laboratories  
17 before sampling begins. The initial and annual MDL evaluation will be performed in accordance  
18 with 40 *Code of Federal Regulations* §136 and with EPA/530-SW-90-021, as revised and  
19 retitled, "Quality Assurance and Quality Control" (Chapter 1 of SW-846) (1996).

#### 20 N-5a(5) Completeness

21 The expected completeness for this program is greater than or equal to 90 percent. Data  
22 completeness will be tracked monthly.

#### 23 N-5b Sample Handling and Custody Procedures

24 Sample packaging, shipping, and custody procedures are addressed in Section N-4c.

#### 25 N-5c Calibration Procedures and Frequency

26 Calibration procedures and frequencies for analytical instrumentation are listed in Section N-4e.

#### 27 N-5d Data Reduction, Validation, and Reporting

28 A dedicated logbook will be maintained by the operators. This logbook will contain  
29 documentation of all pertinent data for the sampling. Sample collection conditions, maintenance,  
30 and calibration activities will be included in this logbook. Additional data collected by other  
31 groups at WIPP, such as ventilation airflow, temperature, pressure, etc., will be obtained to  
32 document the sampling conditions.

33 Data validation procedures will include at a minimum, a check of all field data forms and  
34 sampling logbooks will be checked for completeness and correctness. Sample custody and  
35 analysis records will be reviewed routinely by the QA officer and the laboratory supervisor.

1 Electronic Data Deliverables (**EDDs**) are provided by the laboratory prior to receipt of hard copy  
2 data packages. EDDs will be evaluated within five (5) calendar days of receipt to determine if  
3 VOC concentrations are at or above action levels in Table IV.F.3.b for disposal room monitoring  
4 data or concentrations of concern in Table IV.F.2.c for repository monitoring data. If the EDD  
5 indicates that VOC concentrations are at or above these action levels or concentrations, the  
6 hard copy data package will be validated within five (5) calendar days as opposed to the  
7 fourteen (14) calendar day time frame provided by Section N-3e(2).

8 Data will be reported as specified in Section N-3(e) and Permit Module IV.

9 Acceptable data for this VOC monitoring plan will meet stated precision and accuracy criteria.  
10 The QA objectives for precision, accuracy, and completeness as shown in Table N-2 can be  
11 achieved when established methods of analyses are used as proposed in this plan and  
12 standard sample matrices are being assessed.

### 13 N-5e Performance and System Audits

14 System audits will initially address start-up functions for each phase of the project. These audits  
15 will consist of on-site evaluation of materials and equipment, review of canister and sampler  
16 certification, review of laboratory qualification and operation and, at the request of the QA  
17 officer, an on-site audit of the laboratory facilities. The function of the system audit is to verify  
18 that the requirements in this plan have been met prior to initiating the program. System audits  
19 will be performed at or shortly after to the initiation of the VOC monitoring programs and on an  
20 annual basis thereafter.

21 Performance audits will be accomplished as necessary through the evaluation of analytical QC  
22 data by performing periodic site audits throughout the duration of the project, and through the  
23 introduction of third-party audit cylinders (laboratory blinds) into the analytical sampling stream.  
24 Performance audits will also include a surveillance/review of data associated with canister and  
25 sampler certification, a project-specific technical audit of field operations, and a laboratory  
26 performance audit. Field logs, logbooks, and data sheets will be reviewed weekly. Blind-audit  
27 canisters will be introduced once during the sampling period. Details concerning scheduling,  
28 personnel, and data quality evaluation are addressed in the QAPjP.

### 29 N-5f Preventive Maintenance

30 Sampler maintenance is described briefly in Section N-4d Maintenance of analytical equipment  
31 will be addressed in the analytical SOP.

### 32 N-5g Corrective Actions

33 If the required completeness of valid data (95 percent) is not maintained, corrective action may  
34 be required. Corrective action for field sampling activities may include recertification and  
35 cleaning of samplers, reanalysis of samples, additional training of personnel, modification to  
36 field and laboratory procedures, and recalibration of test equipment.

37 Laboratory corrective actions may be required to maintain data quality. The laboratory  
38 continuing calibration criteria indicate the relative response factor for the midpoint standard will  
39 be less than 30 percent different from the mean relative response factor for the initial calibration.  
40 Differences greater than 30 percent will require recalibration of the instrument before samples

1 can be analyzed. If the internal standard areas in a sample change by more than 40 percent,  
2 the sample will be reanalyzed. If the 40 percent criterion is not achieved during the reanalysis,  
3 the instrument will undergo a performance check and the midpoint standard reanalyzed to verify  
4 proper operation. Deviations larger than 40 percent are an indication of potential instrument  
5 malfunction.

6 The laboratory results for samples, duplicate analyses, LCSs, and blanks should routinely be  
7 within the QC limits. If results exceed control limits, the reason for the nonconformances and  
8 appropriate corrective action must be identified and implemented.

#### 9 N-5h Records Management

10 The VOC Monitoring Programs will require administration of record files (both laboratory and  
11 field data collection files). The records control systems will provide adequate control and  
12 retention for program-related information. Records administration, including QA records, will be  
13 conducted in accordance with applicable DOE, MOC, and WIPP requirements.

14 Unless otherwise specified, VOC monitoring plan records will be retained as lifetime records.  
15 Temporary and permanent storage of QA records will occur in facilities that prevent damage  
16 from temperature, fire, moisture, pressure, excessive light, and electromagnetic fields. Access  
17 to stored VOC Monitoring Program QA Records will be controlled and documented to prevent  
18 unauthorized use or alteration of completed records.

19 Revisions to completed records (i.e., as a result of audits or data validation procedures) may be  
20 made only with the approval of the responsible program manager and in accordance with  
21 applicable QA procedures. Original and duplicate or backup records of project activities will be  
22 maintained at the WIPP site. Documentation will be available for inspection by internal and  
23 external auditors.

#### 24 N-6 Sampling and Analysis Procedures for Disposal Room VOC Monitoring in Filled Panels

25 Disposal room VOC samples in filled panels will be collected using the subatmospheric  
26 pressure grab sampling technique described in Compendium Method TO-15 (EPA, 1999). This  
27 method uses an evacuated SUMMA<sup>®</sup> passivated canister (or equivalent) that is under vacuum  
28 (0.05 mm Hg) to draw the air sample from the sample lines into the canister. The sample lines  
29 will be purged prior to sampling to ensure that a representative sample is collected. The  
30 passivation of tubing and canisters used for VOC sampling effectively seals the inner walls and  
31 prevents compounds from being retained on the surfaces of the equipment. By the end of each  
32 sampling period, the canisters will be near atmospheric pressure.

33 The analytical procedures for disposal room VOC monitoring in filled panels are the same as  
34 specified in Section N-4e.

35

1 N-7 References

- 2 U.S. Department of Energy. 1997. *Resource Conservation and Recovery Act Part B Permit*  
3 *Application, Waste Isolation Pilot Plant (WIPP)*, Carlsbad New Mexico, Re. 6.4, 1997
- 4 U.S. Environmental Protection Agency. 1996. SW-846, *Test Methods for Evaluating Solid*  
5 *Waste, Physical/Chemical Methods*. 3rd Edition. Office of Solid Waste and Emergency  
6 Response, Washington, D.C.
- 7 U.S. Environmental Protection Agency. 1999 *Compendium Method TO-15: Determination of*  
8 *Volatile Organic Compounds (VOCs) In Air Collected in Specially Prepared Canisters and*  
9 *Analyzed by Gas Chromatography/Mass Spectrometry*, EPA 625/R-96/010b. Center for  
10 Environmental Research Information, Office of Research and Development, Cincinnati, OH,  
11 January 1999.
- 12 U.S. Environmental Protection Agency. 2000. *Guidance for the Data Quality Objectives*  
13 *Process*, QA/G-4. EPA 600/R-96/055, August 2000, Washington, D.C.
- 14 U.S. Environmental Protection Agency. 2001. *EPA Guidance for Quality Assurance Project*  
15 *Plans*, QA/G, EPA 240/B-01/003, March 2001, Washington, D.C.
- 16 U.S. Environmental Protection Agency. 2002. *EPA Requirements for Preparing Quality*  
17 *Assurance Project Plans*, QA/R-5, EPA 240/R-01/009, December 2002, Washington, D.C.
- 18 Washington Regulatory and Environmental Services, 2004. *Technical Evaluation Report for*  
19 *WIPP Room-Based VOC Monitoring*.
- 20

1

## **TABLES**

2

1  
2

(This page intentionally blank)



1  
2  
3

**Table N-1**  
**Target Analytes and Methods for Repository VOC (Station VOC-A and VOC-B)**  
**Monitoring and Disposal Room Monitoring**

<b>Target Analyte</b>	<b>EPA Standard Analytical Method</b>
Carbon tetrachloride	EPA TO-15 <sup>a</sup> EPA 8260B <sup>b</sup>
Chlorobenzene	
Chloroform	
1,1-Dichloroethylene	
1,2-Dichloroethane	
Methylene chloride	
1,1,2,2 -Tetrachloroethane	
Toluene	
1,1,1- Trichloroethane	

<sup>a</sup> U.S. Environmental Protection Agency, 1999, Compendium of Methods for the Determination of Toxic Organic Compounds in Ambient Air- Second Edition, <http://www.epa.gov/ttn/amtic/airtox.html>

<sup>b</sup> U.S. Environmental Protection Agency, SW-846 Test Methods for Evaluation Solid Wastes, Chemical and Physical Methods, <http://www.epa.gov/epaoswer/hazwaste/test/main.htm>

4

1  
2

**Table N-2**  
**Quality Assurance Objectives for Accuracy, Precision, Sensitivity, and Completeness**

Compound	Accuracy (Percent Recovery)	Precision (RPD)		Required MRL (ppbv)	Completeness (Percent)
		Laboratory	Field		
Carbon tetrachloride	60 to 140	25	35	2	95
Chlorobenzene	60 to 140	25	35	2	95
Chloroform	60 to 140	25	35	2	95
1,1-Dichloroethylene	60 to 140	25	35	5	95
1,2-Dichloroethane	60 to 140	25	35	2	95
Methylene chloride	60 to 140	25	35	5	95
1,1,2,2-Tetrachloroethane	60 to 140	25	35	2	95
Toluene	60 to 140	25	35	5	95
1,1,1-Trichloroethane	60 to 140	25	35	5	95

MRL method reporting limit

RPD relative percent difference

3

1

## FIGURES

2

1

(This page intentionally blank)

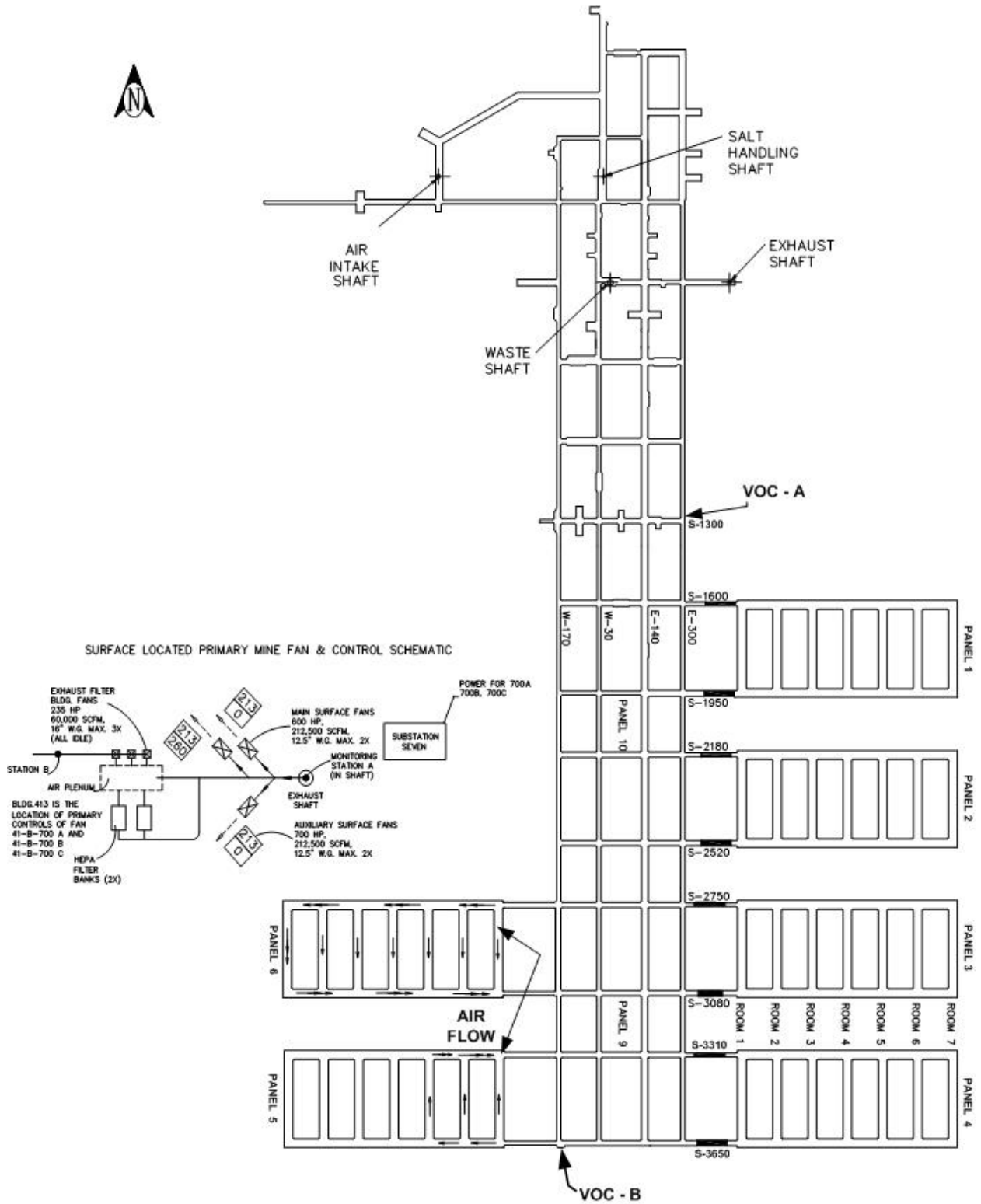

**Figure N-1  
 Panel Area Flow**

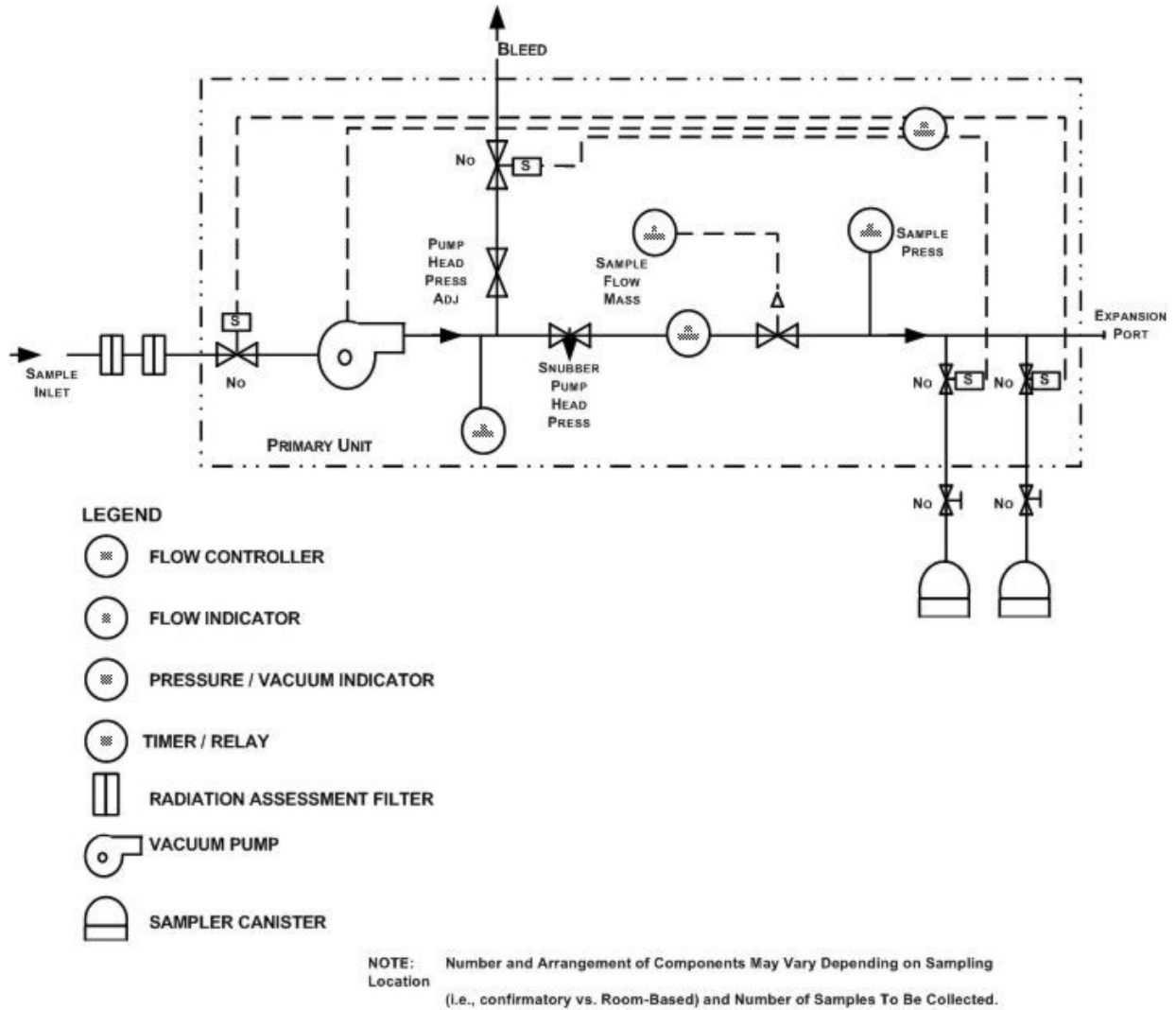

**Figure N-2  
 VOC Monitoring System Design**

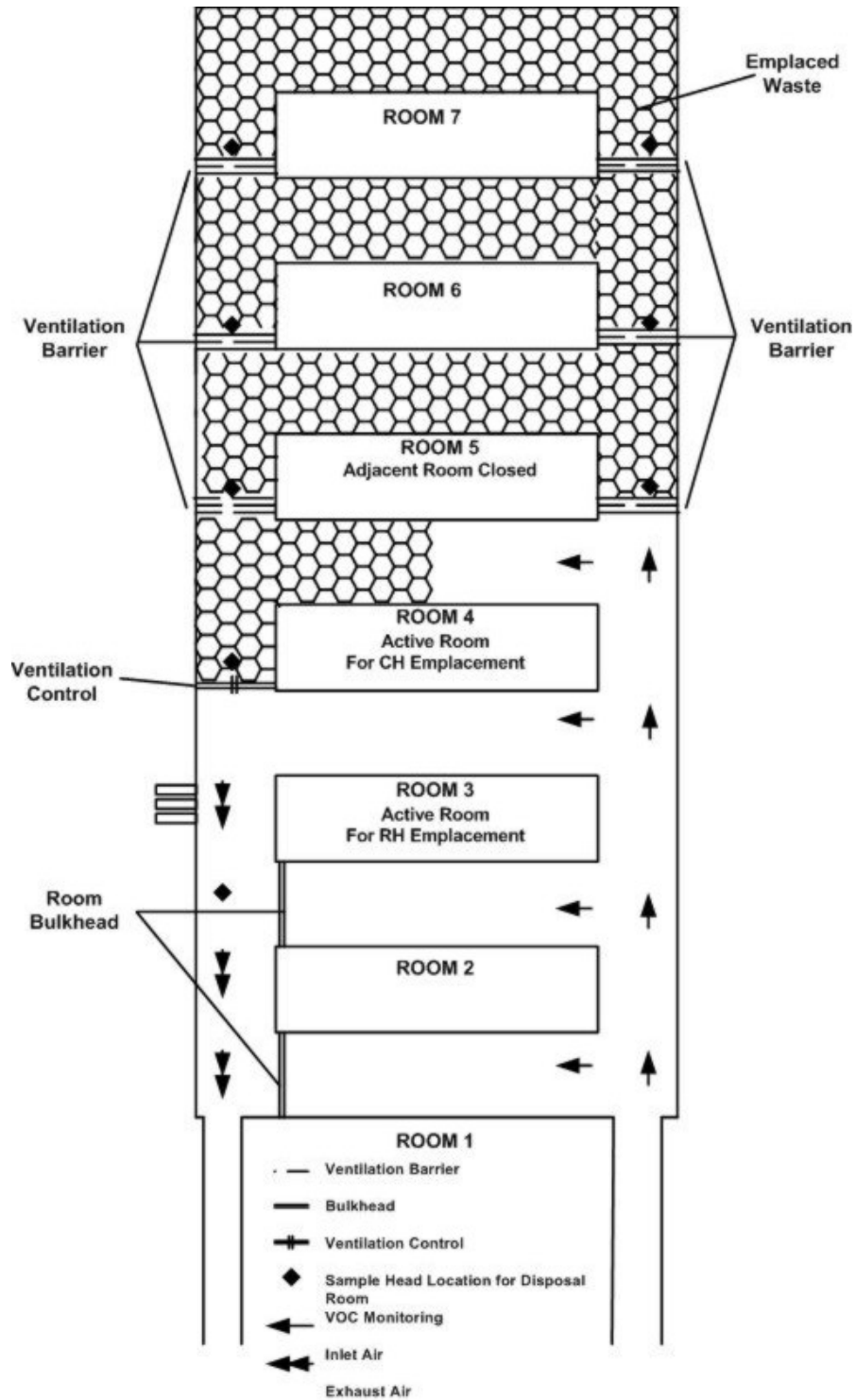

**Figure N-3**  
**Disposal Room VOC Monitoring**

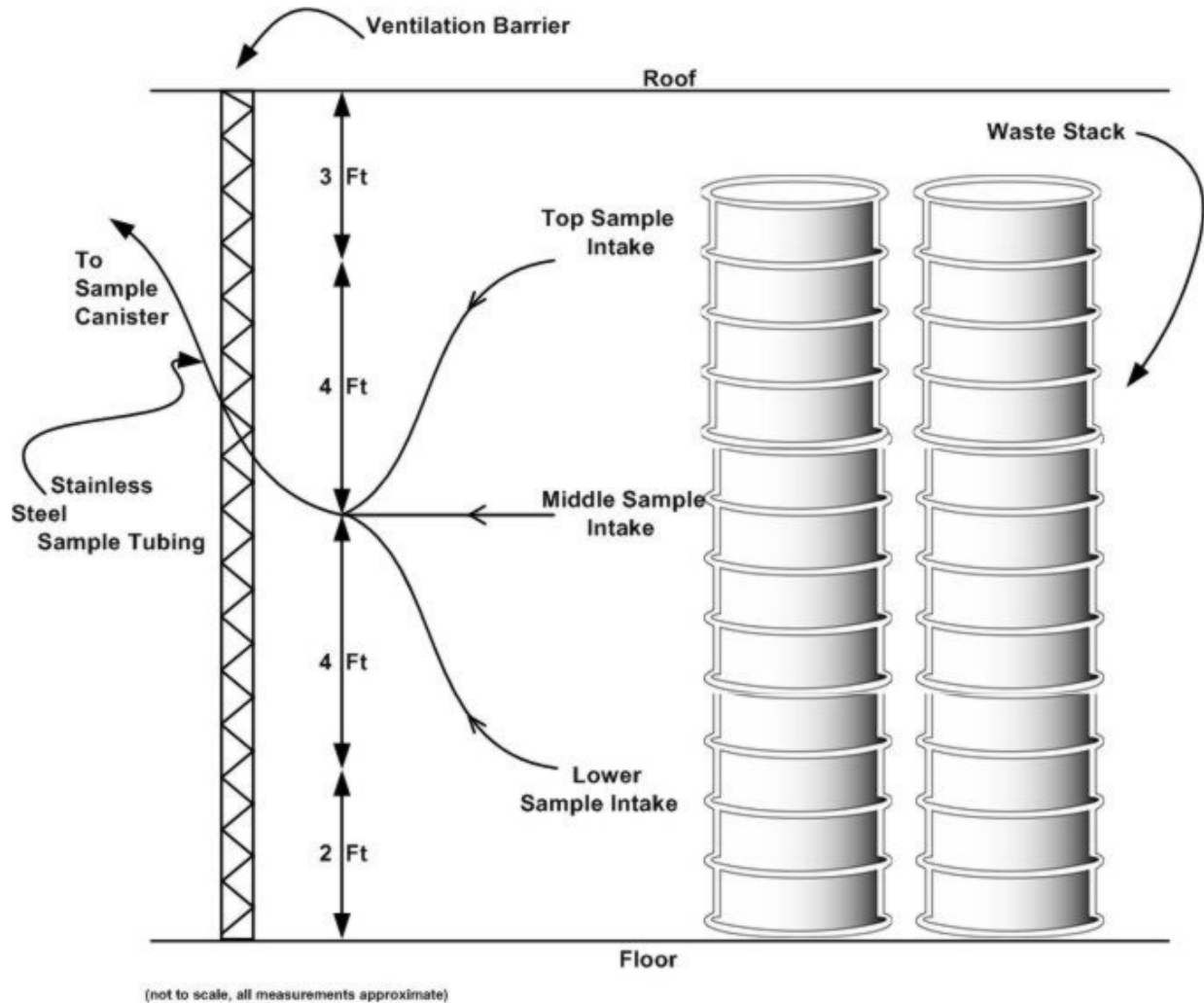

**Figure N-4**  
**VOC Sample Head Arrangement**