

**BRINE SAMPLING AND EVALUATION PROGRAM
1992—1993 REPORT AND SUMMARY OF
BSEP DATA SINCE 1982**

DOE-WIPP 94-011

April 1995

AUTHORS

D. E. Deal—IT Corporation
R. J. Abitz—IT Corporation
D. S. Belski—Westinghouse Electric Corporation
J. B. Case—IT Corporation
M. E. Crawley—IT Corporation
C. A. Givens—IT Corporation
P. P. James Lipponer—IT Corporation
D. J. Milligan—IT Corporation
J. Myers—IT Corporation
D. W. Powers—Consulting Geologist
M. A. Valdivia—IT Corporation

Any comments or questions regarding this report should
be directed to the
U.S. Department of Energy
WIPP Project Office
P. O. Box 3090
Carlsbad, New Mexico 88221

or to the
Manager
Engineering Department
Westinghouse Electric Corporation
Waste Isolation Division
P.O. Box 2078
Carlsbad, New Mexico 88221

This report was prepared for the U.S. Department of Energy by the Engineering Department of the Management and Operating Contractor, Waste Isolation Pilot Plant, under Contract No. DE-AC04-86AL31950.

DISCLAIMER

Portions of this document may be illegible in electronic image products. Images are produced from the best available original document.

**BRINE SAMPLING AND EVALUATION PROGRAM
1992—1993 REPORT AND SUMMARY OF
BSEP DATA SINCE 1982**

DOE-WIPP 94-011

April 1995

AUTHORS

D. E. Deal—IT Corporation
R. J. Abitz—IT Corporation
D. S. Belski—Westinghouse Electric Corporation
J. B. Case—IT Corporation
M. E. Crawley—IT Corporation
C. A. Givens—IT Corporation
P. P. James Lipponer—IT Corporation
D. J. Milligan—IT Corporation
J. Myers—IT Corporation
D. W. Powers—Consulting Geologist
M. A. Valdivia—IT Corporation

Any comments or questions regarding this report should
be directed to the
U.S. Department of Energy
WIPP Project Office
P. O. Box 3090
Carlsbad, New Mexico 88221

or to the
Manager
Engineering Department
Westinghouse Electric Corporation
Waste Isolation Division
P.O. Box 2078
Carlsbad, New Mexico 88221

DISCLAIMER

This report was prepared as an account of work sponsored by an agency of the United States Government. Neither the United States Government nor any agency thereof, nor any of their employees, makes any warranty, express or implied, or assumes any legal liability or responsibility for the accuracy, completeness, or usefulness of any information, apparatus, product, or process disclosed, or represents that its use would not infringe privately owned rights. Reference herein to any specific commercial product, process, or service by trade name, trademark, manufacturer, or otherwise does not necessarily constitute or imply its endorsement, recommendation, or favoring by the United States Government or any agency thereof. The views and opinions of authors expressed herein do not necessarily state or reflect those of the United States Government or any agency thereof.

This report was prepared for the U.S. Department of Energy by the Engineering Department of the Management and Operating Contractor, Waste Isolation Pilot Plant, under Contract No. DE-AC04-86AL31950.

MASTER
DISTRIBUTION OF THIS DOCUMENT IS UNLIMITED

56

This document is issued by Westinghouse Electric Corporation, Waste Isolation Division, as the Management and Operating Contractor for the U. S. Department of Energy, Waste Isolation Pilot Plant, Carlsbad, New Mexico 88221.

DOE CONTRACT NUMBER: DE-ACO4-86AL31950

This document has been submitted as required to:

Office of Scientific and Technical Information
PO Box 62
Oak Ridge, TN 37831
(615) 576-8401

Additional information about this document may be obtained by calling 1-800-336-9477. Copies may be obtained by contacting the National Technical Information Service, US Department of Commerce, 5285 Port Royal Road, Springfield, VA 22161.

Acknowledgments

Dr. Dwight Deal provides overall direction to the Brine Sampling and Evaluation Program (BSEP) at the Waste Isolation Pilot Plant (WIPP) located in Carlsbad, New Mexico.

Dr. Rich Abitz coordinates the geochemical analyses.

Mr. Dave Belski is responsible for the routine collection of brine from the drill holes in the repository, sample measurement and processing, and data analysis.

Mr. Darin Milligan prepared the statistical analysis of the geochemical data (Chapter 3.0).

Mr. Mark Crawley prepared the 1993 file report of the hydrologic testing of the fractured part of the disturbed rock zone beneath the WIPP excavations, which is summarized in Chapter 4.0 and Appendix E.

Dr. Dennis Powers contributed the observations in the air intake shaft (Appendix C).

Ms. Pamela James-Lipponer was responsible for entry, analysis, and quality assurance of the brine inflow data and prepared Appendices A, B, and D.

Mr. Craig Givens edited and condensed Appendices C and E, prepared the final graphs in Appendix B, and wrote Chapter 4.0.

Dr. John Case performed the numerical modeling of brine seepage from clay compaction presented in Appendix F.

Mr. Miguel Valdivia provided extensive support to both the statistical analysis and the numerical modeling. He prepared the final version of Appendix F.

Dr. Jonathan Myers provided input to the discussion of brine geochemistry and on the importance of the BSEP to the assessment of long-term facility performance.

THIS PAGE INTENTIONALLY LEFT BLANK

Table of Contents

Acknowledgments	i
List of Tables	v
List of Figures	vi
List of Abbreviations/Acronyms	vii
Executive Summary	ix
1.0 Introduction	1-1
2.0 Monitoring of Brine Inflow Parameters	2-1
2.1 Introduction	2-1
2.2 Damp or Wet Areas on Drift Floors	2-1
2.3 Downholes and Brine Beneath the Floor	2-1
2.3.1 Downholes	2-1
2.3.2 Shaft Sumps	2-6
2.4 Upholes and Brine Above the Roof	2-6
2.5 Subhorizontal Holes	2-8
2.6 Air Intake Shaft	2-9
2.7 Discussion of Data Acquisition and Analysis	2-10
3.0 Statistical Analysis of the BSEP Brines	3-1
3.1 Introduction	3-1
3.2 Sources of Data	3-2
3.3 Temporal Trends	3-2
3.4 Duplicate Analysis	3-4
3.5 Determination of Statistical Distributions	3-4
3.6 Handling of Values	3-7
3.7 Rejection of Outliers	3-7
3.8 Average Brine Chemistry	3-9
3.9 Composition of Non-Salado Brine from the WIPP Underground	3-19
3.10 Conclusions	3-19
4.0 Hydrologic Testing of the Fractured Part of the Disturbed Rock Zone Beneath the WIPP Excavations	4-1
5.0 Numerical Modeling of Brine Seepage as a Result of Clay Compaction	5-1
5.1 Introduction	5-1
5.2 Modeling Assumptions	5-1
5.3 Room Q	5-2

Table of Contents (Continued)

5.4	Standard WIPP Waste Storage Room	5-2
5.5	Axial Consolidation Around a Borehole	5-3
5.6	Summary	5-4
6.0	Summary and Conclusions	6-1
7.0	References	7-1
	Appendix A—Brine Accumulation	
	Appendix B—Graphs of Brine Accumulation Data	
	Appendix C—AIS Observations	
	Appendix D—1993 Analytical Results	
	Appendix E—Hydrologic Testing	
	Appendix F—Numerical Modeling of Brine Seepage from Clay Compaction	

List of Tables

<i>Table</i>	<i>Title</i>
1-1	Points to be Considered When Evaluating BSEP Data
2-1	Brine Accumulation Summary
3-1	BSEP Drillholes Sampled for Brine between 1987 and 1993
3-2	Simple Statistics for BSEP Analyses
3-3	Average Composition of Salado Formation Brine
3-4	Composition of Salado and Nonsalado Brines
5-1	Seepage Rate in Drillholes Penetrating Clay B

List of Figures

<i>Figure</i>	<i>Title</i>
1-1	WIPP Location in Southeastern New Mexico
1-2	Surface and Underground Layout of the WIPP Facility
1-3	Generalized Stratigraphic Cross Section of the WIPP Site
2-1	Map of the WIPP Underground Workings Showing BSEP Observation Locations as of December 31, 1993
2-2	Correlation of the Stratigraphy to the Downholes in the Northern Part of the Facility
2-3	Correlation of the Stratigraphy to the Upholes in the Northern Part of the Facility
3-1	Uphole A1X02 Concentration vs. Time for B, Br, Mg, and K
3-2	Means Plots for BSEP Drill Holes for B, Br, K, and Mg

List of Abbreviations/Acronyms

AIS	Air Intake Shaft
Al	aluminum
ALK	alkalinity
ANOVA	Analysis of Variance
As	arsenic
ASTM	American Society for Testing and Materials
B	boron
Ba	barium
Br	bromine
BSEP	Brine Sampling and Evaluation Program
Ca	calcium
Cl	chlorine
cm	centimeter(s)
cm/s	centimeter/second
Cs	cesium
DOE	U.S. Department of Energy
DRZ	disturbed rock zone
EPA	U.S. Environmental Protection Agency
F	florine
Fe	iron
ft	foot/feet
I	iodine
K	potassium
Kg	kilogram(s)
L	liter(s)
m	meter(s)
M	Mean
MB	Marker Bed
Mg	magnesium
mg/kg	milligrams per kilogram
mL	milliliter(s)
mm	millimeter(s)
Mn	manganese
MPa	megapascal(s)
N	number of samples
Na	sodium
ND	Not detected
NH ₄	Ammonium
NO ₃	Nitrate
P	phosphorous
Pa	pascal(s)

List of Abbreviations/Acronyms (Continued)

PA	Performance Assessment
Rb	rubidium
S	standard deviation
SO ₄	sulfate
SG	specific gravity
Si	silicon
SNL/NM	Sandia National Laboratories/New Mexico
SPDV	Site and Preliminary Design Validation
Sr	strontium
TDS	total dissolved solids
TIC	total inorganic carbon
TOC	total organic carbon
TRU	transuranic
WIPP	Waste Isolation Pilot Plant

Executive Summary

The data in this report are the result of activities associated with the Brine Sampling and Evaluation Program (BSEP) at the Waste Isolation Pilot Plan (WIPP) during 1992 and 1993. This report is the last one that is currently scheduled in the sequence of reports of new data, and therefore, also includes summary comments referencing important data obtained by BSEP since 1983. These BSEP activities document and investigate the origins, hydraulic characteristics, extent, and composition of brine occurrences in the Permian Salado Formation and seepage of that brine into the excavations at the WIPP. A project concern is that enough brine might be present after sealing and closure to generate large quantities of hydrogen gas by corroding the metal in the waste drums and waste inventory.

When excavations began at the WIPP in 1982, small brine seepages (weeps) were observed on the walls. Brine studies began as part of the Site Validation Program and were formalized as the BSEP in 1985. During eleven years of observations (1982-1993), evidence has mounted that the amount of brine seeping into the WIPP excavations is limited, local, and only a small fraction of that required to produce a maximum amount of hydrogen gas. The data collected through 1991 are discussed in detail and are summarized by Deal and others (1993). This report describes progress made during the calendar years 1992 and 1993 and focuses on four major areas: (1) monitoring of brine inflow, e.g., measuring brines recovered from holes drilled downward from the underground drifts (downholes), upward from the underground drifts (upholes), and from subhorizontal holes from the underground drifts; (2) observations of weeps in the Air Intake Shaft (AIS); (3) further characterization of brine geochemistry; and (4) additional characterization of the hydrologic conditions in the fractured zone beneath the excavations.

Damp or Wet Areas on Drift Floors. Seepage into the one persistently wet area on the floor of the WIPP excavations in Room G (GSEEP), continued to decline in 1992 and 1993, reaching a low value of 0.03 liter (L) per day by December see Comment Section 2.2. GSEEP had, for all practical purposes, dried up by December 31, 1993. No evidence was found of brine flowing upward out of fractures beneath the drift floors in the northern part of the workings. Observations of drillholes penetrating anhydrite Marker Bed (MB) 139 in Room G and in Site and Preliminary Design Validation (SPDV) Room 4 showed that the anhydrite is fractured; however, no brine was seeping out of either the anhydrite or the fractures, providing evidence for no significant flow of brine into the excavations from MB 139. If far-field flow exists through MB 139, moisture or evidence of moisture should be observed at these locations. No evidence of moisture was found. (In the context of brine flow toward the WIPP excavations, far-field flow refers to flow far enough beyond the disturbed rock zone [DRZ] where the salt does not deform in response to the presence of the WIPP excavations.)

Seepage into Drillholes. Seepage into selected vertical downholes in the repository floor were monitored. Four of the ten downholes monitored in 1993 showed fairly steady seepage rates ranging from 0.008 to 0.1 L per day. Six downholes showed decreasing seepage trends. In those downholes where MB 139 could be observed, seepage was not found to be entering

the hole from MB 139. Rather, seepage was observed to be from deeper horizons, which will not be intersected by waste storage rooms or be subjected to the fracturing expected to occur around waste storage rooms.

None of the monitored upholes continue to produce brine. Eleven subhorizontal observation holes (drilled at a slight downward angle) continue to be monitored. Only those four that intersect the orange band (Map Unit 1) continue to have measurable seepage, which was 0.005 to 0.01 L per day.

Seepage into Shaft Sumps. Observations in the shaft sumps show that open fractures in MB 139 remain dry. The shaft sumps are, in effect, long-term far-field flow experiments.

Seepage into the Air Intake Shaft. The AIS was inspected for evidence of brine inflow and only one small moist area was observed. It occurs at the base of MB 103, in the upper part of the Salado Formation not far below the Rustler-Salado contact. Salt encrustations (evidence of past brine seepage) occur more commonly below 1,500-ft depth, are clearly stratigraphically controlled, and are associated with clay interbeds and argillaceous halite. The AIS is, in effect, a long-term far-field flow experiment. The anhydrite exposures are typically dry and free of salt encrustations, indicating that no significant amount of brine flows through them to the shaft.

Geochemistry. The general trends of the 1992-1993 geochemistry data are similar to those discussed by Deal and others (1991b, Chapter 3, Table 3-5 and 3-3). Long-term trends of strontium values have been decreasing for samples collected from drillhole DHP402A. A high strontium signature is characteristic of brine that originated as water from the Rustler Formation and was spread for dust control. The lowering of strontium values is consistent with the hypothesis that there is less dilution from construction water derived from the Rustler Formation occurring at the location of DHP402A in Panel 1.

Data from eleven drillholes that have not been contaminated with construction brine form two very similar brine populations. One population are those holes that contain brine derived from the repository horizon and the other, holes that contain brine only from horizons below the floor of the repository. Brines associated with the repository horizon are slightly higher in Mg and Br and lower in K and B than brines from stratigraphic horizons (probably clay B) below the excavations. An average composition for the repository horizon brines that might come into contact with the waste after sealing and closure is presented in Table 3-3.

Hydraulic Tests in the Fractured Part of the DRZ. Fractures are common in the WIPP underground, and fracture systems locally connect brine-filled drillholes at some drift intersections. Fracturing creates pathways that can greatly alter apparent flow rates to individual downholes.

Hydrologic tests were performed in the fractured part of the DRZ at the following three locations:

- Intersection of S90 and W620 near the AIS
- Intersection of W170 and S400 at the Underground Core Storage Area
- Intersection of E0 and N620.

The test results confirmed that the width of an excavation influences the development of integrated fractures and showed that integrated fracture systems were only found beneath intersections. This supports the concept of limited, bounded, fractured fluid reservoirs. Since brine stands at different levels in closely spaced drillholes in the floor and is not seeping out of fractures observed in the Salt Shaft and Waste Shaft sumps, it can be concluded that large-scale hydrologically interconnected fracture systems do not exist below the WIPP underground excavation.

Numerical Modeling of Brine Seepage as a Result of Clay Compaction. It has previously been pointed out (Deal and others, 1993, Sections 4 and 5; Deal and Bills, 1994) that there appears to be enough moisture present in the clays within the Salado Formation to account for all the brine that is observed to seep into the WIPP excavations. The excavation of WIPP rooms result in stress redistribution around those openings that can cause the consolidation of thin clays within the stratigraphic sequence. Additionally, the excavations (including drillholes) provide a sink at atmospheric pressure allowing brine to flow from the consolidating clays.

A series of order-of-magnitude seepage calculations (Appendix F) were made in order to numerically model clay consolidation and estimate the resultant brine seepage into the WIPP.

These order-of-magnitude seepage calculations compare well with the observed seepage into Room Q. Calculated seepage rate after 1,600 days is on the order of 0.3 L/day, where the actual observed rate is 0.17 L/day. In this case the model is for flow towards the room along a thin clay seam. Extending this model to a waste storage room predicts that the total seepage into the room will be on the order of 9,000 L, far short of the 220,000 L necessary to react anoxically with all the susceptible metal placed in the room (Deal and others, 1991b, Section 4.6). Furthermore, seepage into the room will cease after about 100 years.

The case for seepage into a downhole drilled into the strata below a WIPP excavation behaves differently, as flow is radially toward the drillhole rather than parallel to the wall of a room. In this case, some seepage continues for a long time, perhaps a thousand years or more. It is clear that seepage into drillholes is strikingly different from seepage into a repository excavation. Deal and others (1994, Section 2.7.2) pointed out that seepage into drillholes probably should not be used to predict long term seepage into a WIPP waste storage room. The calculation provides additional support for this caution.

THIS PAGE INTENTIONALLY LEFT BLANK

1.0 Introduction

The Waste Isolation Pilot Plant (WIPP), a U.S. Department of Energy (DOE) research facility, was established to demonstrate the safe disposal of defense-generated transuranic (TRU) waste in the United States. The WIPP facility is 26 miles (42 kilometers) east of Carlsbad, New Mexico (Figure 1-1). The surface and underground layout of the facility is presented in Figure 1-2. The repository is approximately 2,150 feet (ft) (655 meters [m]) below the surface in the Salado Formation. The Salado Formation and underlying Castile Formation make up an evaporite sequence over 3,300 ft (1,000 m) thick (Figure 1-3). An extensive program of site characterization was initiated in 1976 (Powers and others, 1978; Bechtel, 1983) and continued through 1991 (Deal and others, 1993). The hydrogeological activities of the Brine Sampling and Evaluation Program (BSEP) are part of a continuing effort to refine the understanding of the repository geology. The data in this report update the previous studies summarized in Deal and others (1993) and in Deal and Bills (1994).

Brine studies began in 1982 as part of the Site Validation Program (Black and others, 1983) and were formalized in 1985 by Morse and Hassinger (1985). The focus of the BSEP is the origin, hydraulic characteristics, extent, and chemical composition of brine in the Salado Formation at the repository horizon and seepage of brine into the excavations at the WIPP. Although the repository is dry, brine weeps from exposed surfaces, accumulates in drillholes and sumps, and forms encrustations on the walls as the brine evaporates over time. The chemistry of the brine may affect chemical reactions in the buried waste, and the volume of brine and the hydrologic system that drives the brine seepage need to be known in order to assess the long-term performance of the repository after closure.

Brine inflow systems have been discussed in previous BSEP reports. There are three different conceptual models that have been considered:

- Far-field Flow Model: flow from the far-field, either by radial flow to the excavation or laterally through stratigraphically-constrained flow.
- Redistribution Model: movement of interstitial brine within the disturbed rock zone (DRZ) toward the excavations by excavation-induced stress redistribution. This does not consider displacement of brine from inside the clays, only redistribution of brine already in available pore spaces in the salt, polyhalite, and anhydrite units.

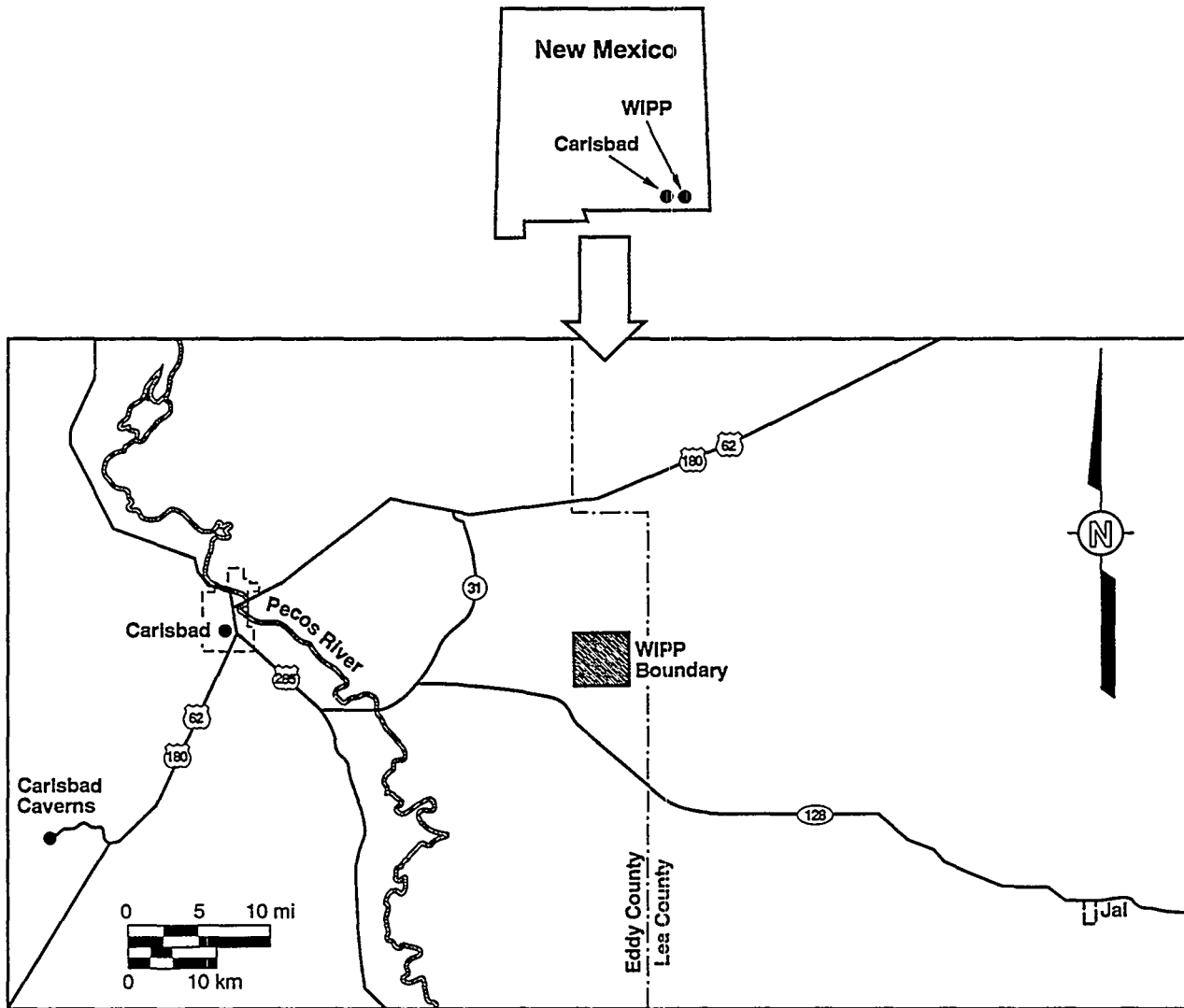

Figure 1-1
WIPP Location in Southeastern New Mexico

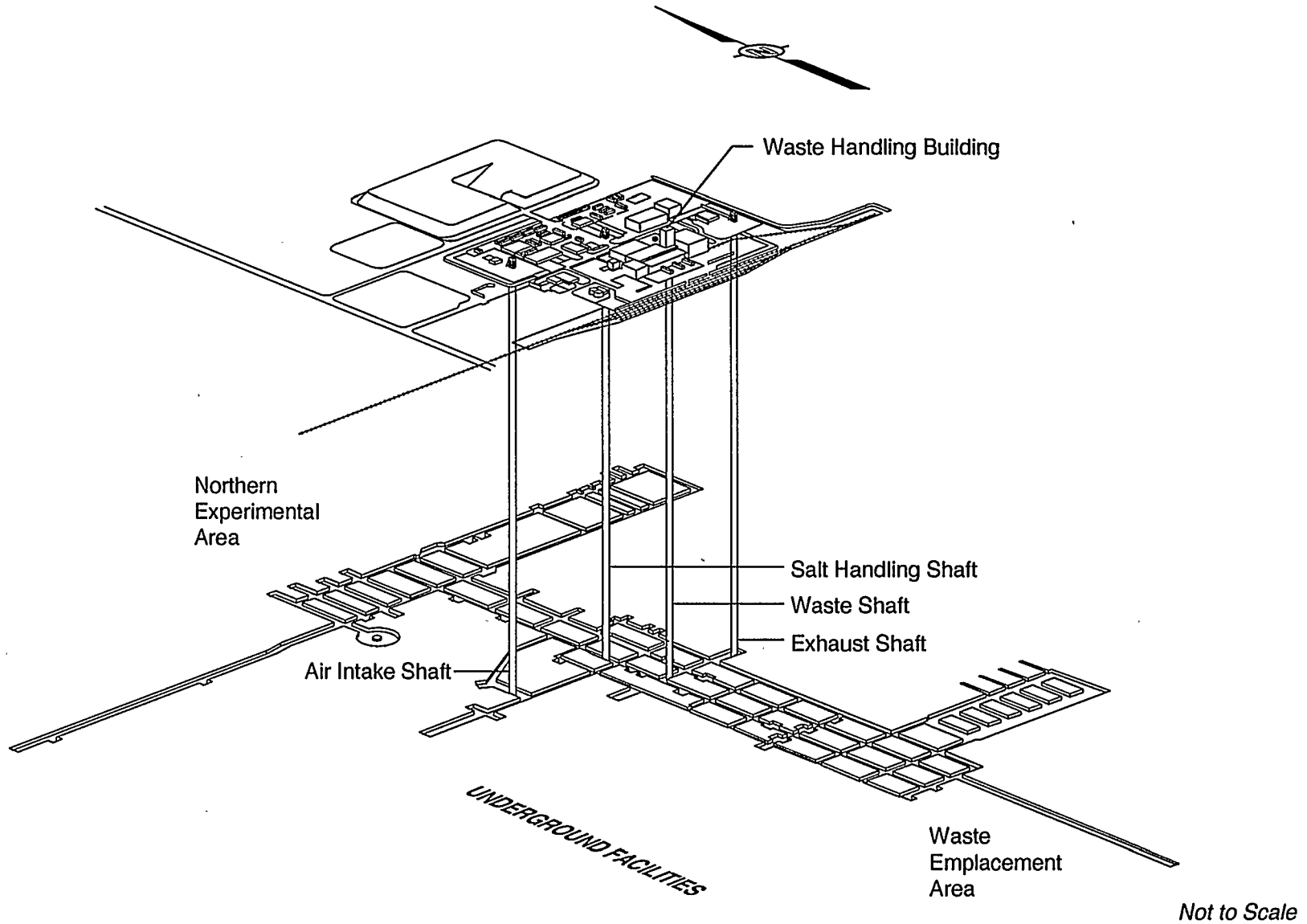

Figure 1-2
Surface and Underground Layout of the WIPP Facility

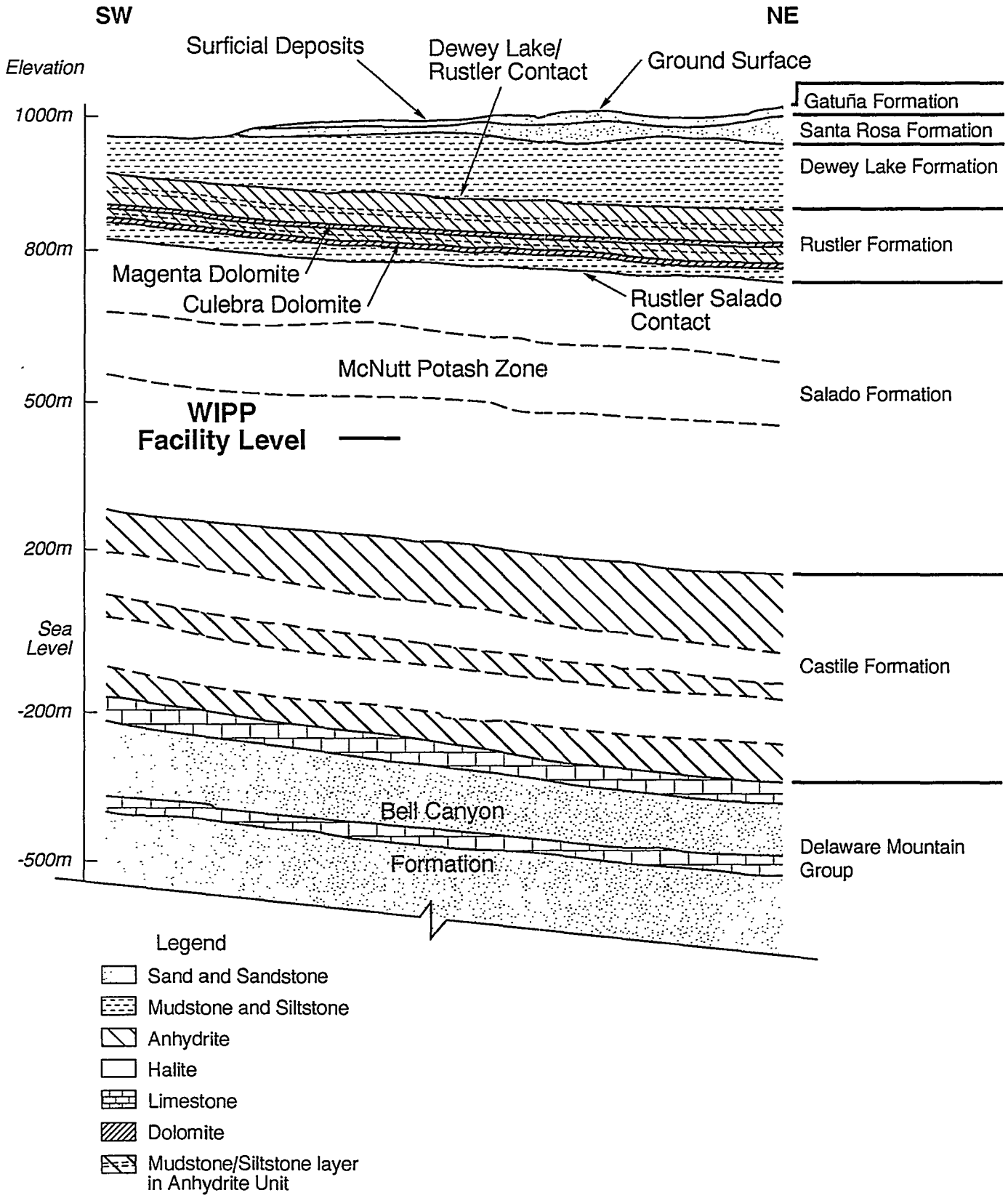

Figure 1-3
Generalized Stratigraphic Cross Section
of the WIPP Site

- Clay Compaction Model: brine squeezed from clays within a short distance (a few m) of the excavations.

Additional effects, such as gas exsolution, development of enhanced porosity and permeability within the DRZ, and preferential flow along bedding planes, may modify brine inflow. However, it is fundamentally important to distinguish between far-field sources and local, relatively limited redistribution of brine in the immediate vicinity of the WIPP excavations. In both cases, the driving mechanism is the pressure gradient caused by the excavation of the underground openings. Flow pathways are through permeable interbeds, along stratigraphic discontinuities, or through fractures.

The relative importance of these systems needs to be determined. For example, if there is sufficient far-field flow into the repository, enough brine may come into the excavations to completely corrode the metal in the waste and the waste drums. In that case, the potential for hydrogen generation due to the corrosion would be limited by the total metal inventory. If brine seepage is a purely local phenomenon that occurs as a result of redistribution of brine in the immediate vicinity of the excavations, there would be insufficient brine available to cause much corrosion after closure. In the latter case, gas generation would be limited by brine availability and would not be a problem. Evidence suggests that brine is derived from clay within a few meters of the excavations, and will not result in the production of large quantities of hydrogen gas by anoxic corrosion.

The predicted consequences of human-intrusion events, the fate of the waste-generated gases, and the migration of the hazardous constituents during undisturbed performance are all sensitive to brine inflow assumptions. If the far-field model is valid, a human-intrusion event (i.e., drilling into the sealed repository at a future date) will lower fluid pressure in the waste storage rooms, create pressure gradients toward the rooms, and reinstate far-field flow. This will lead to a greater release of radionuclides from the repository, because the inflowing brine would infiltrate through the waste and flow up the drillhole. Alternatively, if a near-field model is valid, the only brine available for transport of radionuclides is the volume of brine that is trapped in the room at the time of sealing.

Collection techniques and certain general observations should be kept in mind when evaluating the BSEP data. These are listed in Table 1-1. Care should also be exercised when

Table 1-1
Points to be Considered When Evaluating BSEP Data

<p>Many of the downholes and sumps are contaminated with water spread on the floor for construction purposes or salt-dust control (Deal and others, 1989).</p>
<p>Redistribution of stress around the WIPP excavations as the openings age can cause significant changes in inflow rates, as observable in upholes and downholes.</p>
<p>All downholes were originally pumped with a bailer on a two-week interval. During 1989, pressure-suction moisture-collection devices were installed in the holes. These devices have a capacity of less than one liter, and the sampling frequency was increased to once a week. The limited capacity of the collection device requires sampling on the following day for quantities of a half liter or more, after which the two-day volume measurements are then summed (see Appendix A).</p>
<p>Brine seepages in the Salado Formation (Deal and others, 1989) are small and chemically distinct from brines in the Rustler Formation. The Salado brines are also chemically distinct from brines in the Castile Formation.</p>
<p>Brine occurrences, particularly those evidenced as halite efflorescences or salt encrustations, are ubiquitous on walls but not on the roof in recently mined areas throughout the WIPP underground.</p>
<p>Brine seepage rates into test drillholes are low, usually on the order of a few hundredths of a liter per day or less.</p>
<p>Although small when measured in terms of liters per day at any given location, cumulative seepage volumes may be significant when measured in terms of the entire repository over many years.</p>
<p>Brine seepage into downholes can vary several orders of magnitude between locations, even when locations are less than one meter apart.</p>
<p>Upholes and downholes show a pattern of an initial, maximum flow rate that declines to a steadier flow rate during the observation period. Many upholes dried up completely.</p>
<p>Vertical drillholes yield inconsistent data, but horizontal drillholes provide consistent and comparable data sets.</p>
<p>Flow in these very low-permeability units is quite complex, has very low velocities, appears to involve small volumes of brine, and requires testing over long periods of time during which the very properties being tested change; therefore, the flow parameters are difficult to quantify.</p>

interpreting the various diagrams of drillhole lengths and stratigraphic thicknesses. Although the strata at the WIPP are quite uniform in both composition and thickness, some variation occurs.

Activities in 1992 and 1993 provided additional information on the brine seepage in the repository (Chapter 2.0), geochemical properties of the brine (Chapter 3.0), and additional hydrologic testing (Chapter 4.0). This report supplements the summary of data through 1991 reported and discussed by Deal and others (1993).

Appendix A provides detailed information of the brine seepage into drillholes monitored for this program. The information includes the name of the drillhole; the date and time of brine collection or sampling; the volume (in liters) removed; the number of days since January 1, 1985 (an arbitrary reference date); the cumulative volume (L) collected; the inflow rates in L per day, and specific remarks. Appendix B contains graphs of the data from Appendix A, presented as an 11-point moving average of the data. This averaging reduces variation introduced by collection techniques and presents a more realistic picture of the real variations in brine seepage rates than would be presented by plots of raw data. Appendix C documents brine weeps observed in the AIS. Appendix D shows the results of the chemical analyses, including ion concentrations in milligrams per liter (mg/L), pH, specific conductivity, and alkalinity. Appendix E documents additional hydrologic testing of the fractured zone beneath the floor of the WIPP excavations.

THIS PAGE INTENTIONALLY LEFT BLANK

2.0 Monitoring of Brine Inflow Parameters

2.1 Introduction

Brine seepage observations have been made at underground locations at the WIPP from 1982 to December 31, 1993. Information regarding the inflow of brine was derived from observations and mapping of moist areas and measurements of brine seeping into downholes, upholes, and subhorizontal holes drilled from the underground excavation. The locations of the 1992–1993 BSEP observation holes, along with other reference locations, are shown in Figure 2-1. Descriptions and the underground locations of these boreholes are listed in Table A-1 of Appendix A. Part II of Appendix A lists the quantity of brine removed, calculated inflow rates in liters per day, and cumulative volume in liters for all of the boreholes monitored in 1992 and 1993.

2.2 Damp or Wet Areas on Drift Floors

A brine seep, GSEEP, on the floor of Room G, at approximately N1100-W1140, has been the only persistently moist area in the WIPP excavations. Inflow data for GSEEP are contained in Appendix A, with a smoothed, moving-average graph of the data presented in Appendix B. A description of the location and a discussion of the brine chemistry and seepage history through December 1990 are contained in Deal and others (1991b, Section 2.5), who conclude that the brine from GSEEP has a component from brine spread in the G Access drift for salt-dust control. Note that although no construction water was spread at the location of GSEEP in Room G, water was spread in the G Access Drift which is topographically higher (uphill) of GSEEP. The seepage rate reached a maximum of 0.75 L per day in April 1989 but declined to 0.03 L per day by December 1993. GSEEP had, for all practical purposes, dried up by December 31, 1993. A total of 1,099 L have been collected, and a thick salt encrustation on the floor indicates that more has evaporated into the air circulated through the WIPP workings for ventilation.

2.3 Downholes and Brine Beneath the Floor

2.3.1 Downholes

Downholes are drilled vertically downward into the repository floor. Deal and Case (1987, Table 3-1) discussed brine inflow in 13 downholes, with observations beginning in late 1984 and early 1985. A detailed discussion of sampling, data scattering, and inflow rates through

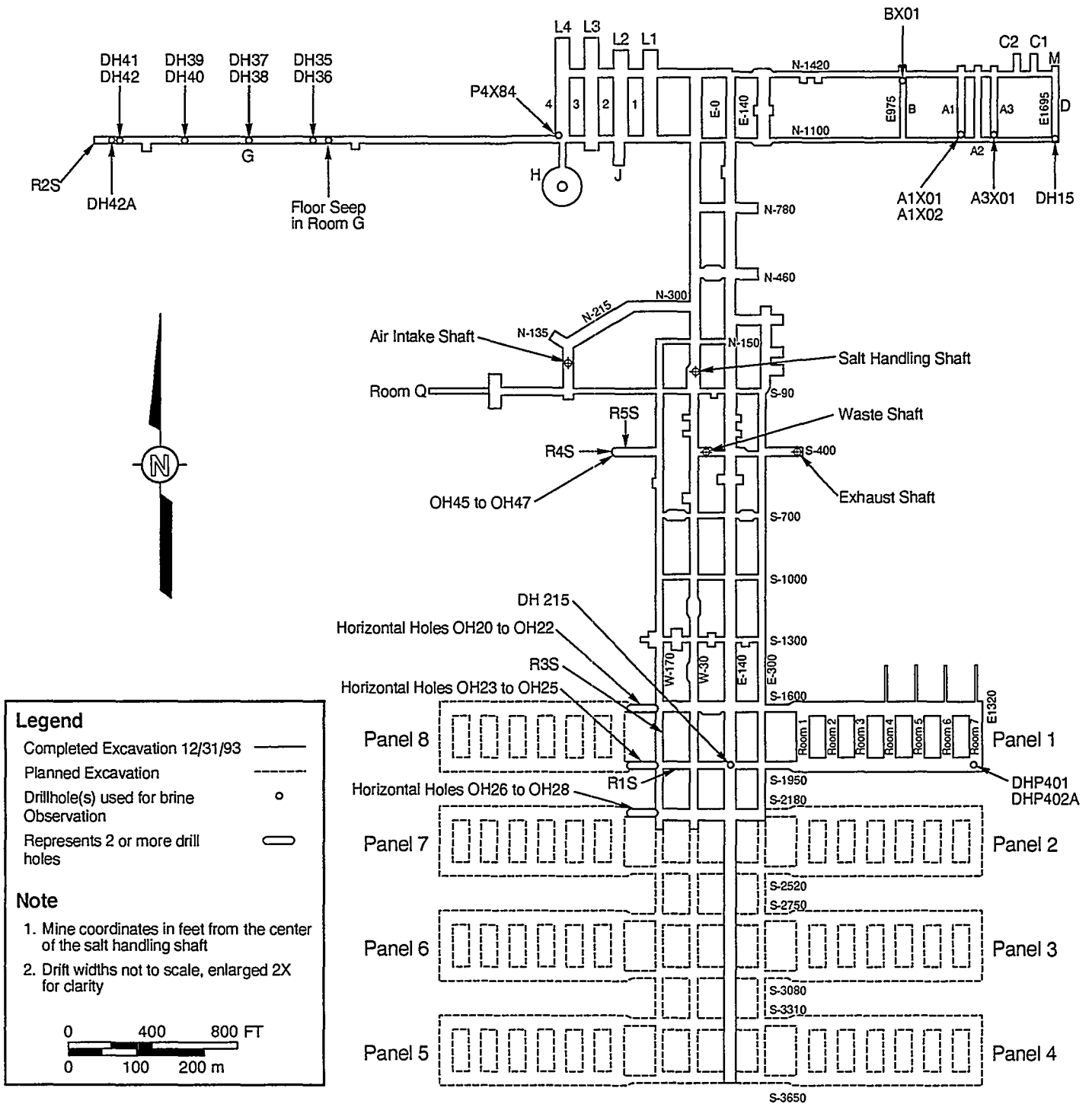

Figure 2-1

Map of WIPP Underground Workings Showing BSEP Observation Locations as of December 31, 1993

the end of 1990 is presented in Deal and others (1991b). Five of the ten downholes monitored in 1993 showed steady inflow (A3X01, BX01, DH36, DH38, and DH40). Downholes DH42 and DH42A showed a decrease in inflow rate as did DHP402A in Panel 1 and OH46 neither of which were included in the original 13 downholes drilled in 1984. Five of the original 13 holes (A1X01, IG201, IG202, L1X00, and NG252) could no longer be observed. Table 2-1 summarizes the data obtained from the downholes, with additional information presented in Appendix A.

Contamination with non-Salado water used for construction purposes has been confirmed in most downholes by the chemical composition of the brine, which clearly indicates the mixing of waters with discrete and different chemical signatures (Deal and others, 1989; 1991b; 1993). In some cases, inflow rates vary directly with known water-spreading practices. The first seven downholes in Table 2-1 are located in the northern part of the repository (Figure 2-1), where water was not spread during construction; therefore, the brine collected from these downholes was derived from within the Salado Formation. Brine chemistries from these holes differ from chemical signatures associated with construction brines.

These seven downholes have a similar nine-year seepage pattern (Appendix B), although these holes penetrate different stratigraphic horizons (Figure 2-2) and the seepage rates vary more than two orders of magnitude. These holes were drilled into relatively undisturbed salt shortly after excavation and then monitored. The following observations, first made in 1986 (Deal and Case, 1987), have been confirmed:

- After drilling a hole, a few days elapse where little or no brine seeps into the hole.
- After the initial no-flow or low-flow period, brine seepage quickly reaches a maximum and then begins to decline.
- Seepage rates decrease over a period of several months to steadier, long-term trends.

Five of the downholes demonstrated a steady flow (within the scatter of the data points) through 1993, though slightly decreased from past years, and four showed a decrease in inflow.

Table 2-1
Brine Accumulation Summary

Downholes								
Hole	Location	Date Area Excavated	Date Hole Drilled	Date First Observed	Approx. Maximum Inflow (L/Day) ^a	Approx. Inflow 12/93 (L/Day)	Inflow Trend 12/93 ^b	Approx. Total Vol. Removed by 12/93 (L)
A3X01	Room A3	11/84	1/85	2/85	0.03	0.02	S	65
BX01	Room B	6/84	1/85	1/85	0.06	0.03	S	118
DH36	Room G	12/84	1/85	1/85	0.28	0.1	S	482
DH38	Room G	12/84	1/85	1/85	0.18	0.03	S	135
DH40	Room G	12/84	1/85	1/85	0.04	0.008	S	22
DH42	Room G	12/84	1/85	1/85	0.05	0.01	D	68
DH42A	Room G	12/84	1/85	1/85	0.2	0.02	D	245
DHP402A	S1950/E1330	10/86	12/86	12/86	4.0	0.02	D	644
OH46	S390/W320	5/89	6/89	7/89	0.04	0.005	D	21
Upholes								
Hole	Location	Date Area Excavated	Date Hole Drilled	Date First Observed	Approx. Maximum Inflow (L/Day) ^a	Approx. Inflow 12/93 (L/Day)	Inflow Trend 12/93 ^b	Approx. Total Vol. Removed by 12/93 (L)
A1X02	Room A1	10/84	3/85	3/85	0.09	0	DRY	83
DH15	N1104/E1688	3/84	3/84	5/86	0.01	0	DRY	4
DH35	Room G	12/84	1/85	2/85	0.02	0	DRY	4
DH37	Room G	12/84	1/85	2/85	0.01	0	DRY	1
DH39	Room G	12/84	1/85	2/85	Trace	0	DRY	0
DH41	Room G	12/84	1/85	2/85	Trace	0	DRY	0
DH215	S1960/E153	1/83	2/83	4/84	0.09	0	DRY	18
DHP401	S1950/E1330	10/86	1/87	3/87	0.008	0	DRY	2
OH47	S390/W320	5/89	7/89	8/89	0.030	0	DRY	4
Subhorizontal Holes								
Hole	Location	Date Area Excavated	Date Hole Drilled	Date First Observed	Approx. Maximum Inflow (L/Day) ^a	Approx. Inflow 12/93 (L/Day)	Inflow Trend 12/93 ^b	Approx. Total Vol. Removed by 12/93 (L)
OH20	S1600/W170	9/85	3/89	3/89	0.02	0.005	S	16
OH21	S1600/W170	9/85	12/88	2/89	0	0	DRY	0
OH22	S1600/W170	9/85	12/88	2/89	0.006	0	DRY	1
OH23	S1950/W170	12/85	2/89	2/89	0.06	0.01	D	28
OH24	S1950/W170	12/85	3/89	3/89	0.002	0	DRY	1
OH25	S1950/W170	12/85	3/89	3/89	0.001	0	DRY	0.1
OH26	S2150/W170	8/86	3/89	3/89	0.04	0.01	D	27
OH28	S2150/W170	8/86	4/89	4/89	0.008	0	DRY	2
OH45	S390/W325	5/89	6/89	6/89	0.03	0.003	S	7

^aLiters (L) per day.^bTrend derived from data presented in Appendices A and B—Dry; Decreasing (D); Steady (S).

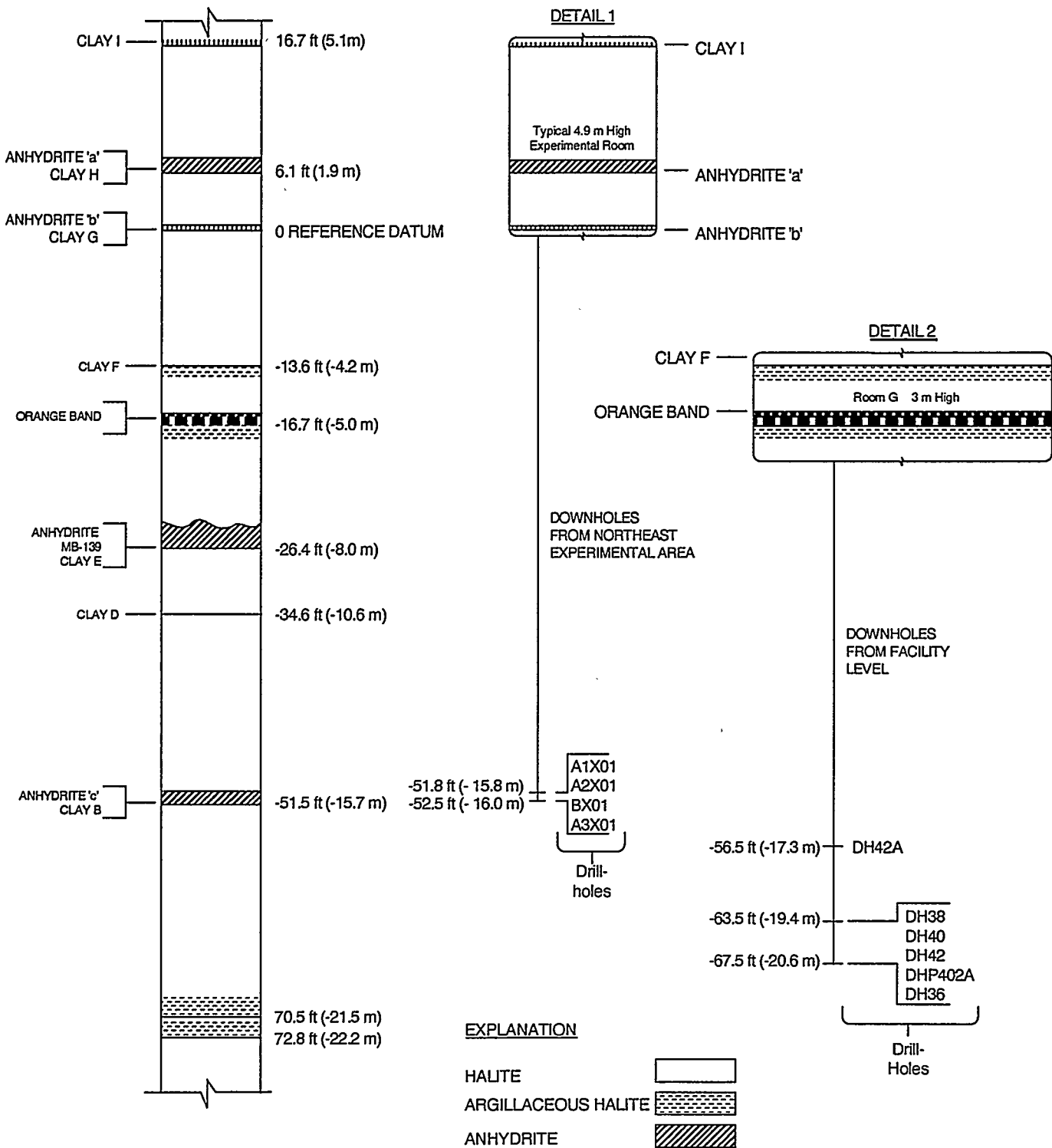

NOTE: Distances above and below anhydrite "b" (clay G) vary from place to place in the WIPP excavations due to natural changes in stratigraphic thickness. This figure represents thicknesses in the northern part of the facility. Distances from clay E down are from Room G and from the orange band up are from Room A1.

Figure 2-2
Correlation of the Stratigraphy to the Downholes
in the Northern Part of the Facility

2.3.2 Shaft Sumps

Deal and others (1991b, Section 2.7.1) discuss observations made in the Salt Shaft and Waste Shaft sumps, where MB 139 and open fractures can be seen. The sumps were inspected again in 1991 (Deal and others, 1993) and again in 1993. The fractures and MB 139 were found to be dry and did not contain large quantities of salt encrustations. The shaft sumps are, in effect, long-term far-field brine inflow experiments. If significant amounts of brine were flowing toward the repository through MB 139, brine should be found in the shaft sumps. The fact that brine is not observed seeping from MB 139 in the shafts is evidence that significant far-field flow does not exist.

2.4 Upholes and Brine Above the Roof

Upholes are drilled vertically upward into the repository roof. Upholes characteristically produce less brine for shorter periods of time than downholes. Part of this can be attributed to greater evaporation caused by less effective sealing of upholes (Deal and Case, 1987) and loss of moisture by dispersion from the hole collar into the salt. Loss of moisture by evaporation is evident from salt-crust buildup in and around most of the upholes. Chemical data (Chapter 3.0 of this report; Deal and others, 1989, 1991a, and 1991b; Abitz and others, 1990) confirm compositional differences between brine samples from upholes and downholes, which can be explained by the partial evaporation of a brine with typical downhole composition to produce the uphole brine. Although the stratigraphy exposed in the upholes (Figure 2-3) is slightly different from the stratigraphy exposed in the downholes, it is unclear whether this contributes significantly to the differences in either brine quantity or chemistry (Deal and others, 1989).

Summary data for selected upholes are presented in Table 2-1. None of the nine upholes listed in 1985 continue to produce brine (upholes A2X02, A3X02, and BX02 are no longer monitored). As discussed in Deal and others (1991b), A1X02 is longer than any of the other upholes (59 ft [18 m]) and intersects an additional anhydrite unit not penetrated by any other uphole. No associated clay was observed in the core, but clay commonly occurs below anhydrite stringers and may be discontinuous at this horizon. Additional data are presented in Appendix A. During 1992 and 1993, inflow data for A1X02 continues to be sporadic. The hole is in Room A1, which is inaccessible. A1X02 has not been monitored since August 19, 1993.

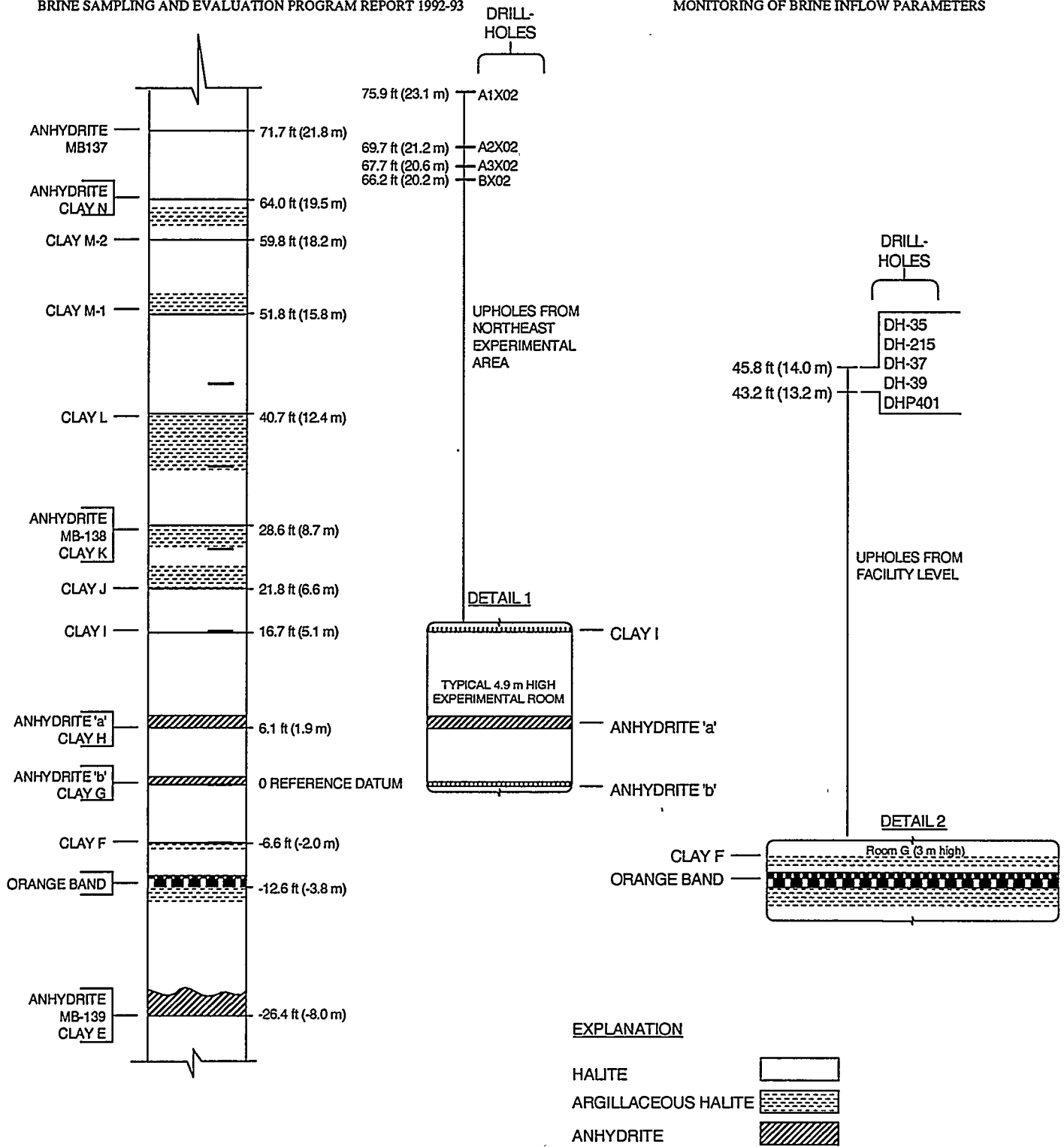

NOTE: Distances above and below anhydrite "b" (clay G) vary from place to place in the WIPP excavations due to natural changes in stratigraphic thickness. This figure represents thicknesses in the northern part of the facility. Distances below the zero datum (clay G) are from Room G, distances above clay G are from Room A1.

Figure 2-3
Correlation of the Stratigraphy to the Upholes
in the Northern Part of the Facility

Drillholes in the roof that intersect overlying clay layers (clays J and K and argillaceous halite between the two clays), including those for the placement of rock bolts, commonly drip brine for a period of several months, often forming halite stalactites. Seepage is particularly notable when the drifts are allowed to age for several years, allowing bed separations to form prior to drilling.

The undisturbed roof of the workings at the WIPP rarely shows evidence of brine seeps or weeps (Deal and others, 1987, Section 2.2). Drill holes provide a route for brine to move across effectively impermeable clear halite beds, and seepage from drillholes in the roof is a common occurrence at the WIPP. Typically upholes start to show evidence of brine seepage a month or so after drilling, exhibit their most active seepage for the following year or so, and then gradually dry up. Rooms C1 and C2 show this very typical behavior (Deal and others, 1991b, Section 2.8.1).

2.5 Subhorizontal Holes

Subhorizontal brine sampling holes are drilled at a slight downward angle. During 1989, 11 subhorizontal holes were drilled to investigate brine seepage from the WIPP facility stratigraphic horizon. The holes were oriented slightly downward from the opening to accumulate brine at the end of the hole where it could be collected and measured without loss to fractures near the surface of excavations. Ten of the eleven holes were drilled westward from the W170 drift at the location of future entries to Panels 7 and 8 at S1600, S1950, and S2180 (Figure 2-1). These portions of the W170 were excavated in September 1985 at S1600, in December 1985 at S1950, and in August 1986 at S2180 and are considered to have a mature DRZ around them. Three of the holes (OH20, OH23, and OH26), which are 150 ft (46 m) long and 3 in. (7.6 centimeters [cm]) in diameter, started in the clayey halite (Map Unit 4) above the orange band (Map Unit 1) and are deflected slightly downward (Deal and others, 1993, Figures 2-18, 2-19, and 2-20), so that they end in the clear halite (Map Unit 0) below the orange band. The 150-ft (46-m) holes reached the orange band about 50 ft (15 m) into the holes. Hole OH27A was started at the initial location for OH27 but was terminated at a depth of 4 ft (1.2 m) because of drilling problems. The six remaining 50-ft (15-m) holes were drilled either above or below the orange band. One 50-ft (15-m) hole (OH45), which cuts the same stratigraphic interval as the three 150-ft (46-m) holes, was drilled in a newer excavation in May 1989 at S400.

Several of these holes have produced measurable quantities of brine (Table 2-1, Appendix A). The 150-ft (46-m) holes provide the most uniform and comparable set of measurements yet obtained in the BSEP and have all produced several orders of magnitude more brine than the 50-ft (15-m) holes. The longer holes are still producing, while the shorter holes are essentially dry (i.e., they have not produced enough brine to be measured by the equipment and techniques used), with the exception of OH45. OH45 is a 50-ft (15-m) hole that cuts the same stratigraphic interval as the 150-ft (46-m) longer holes but that was drilled in a more recently mined area at S400, over 1,000 ft (300 m) north of OH20, OH23, and OH26. Lateral variation may play a minor role in the difference in brine seepage. This is considered to be unlikely, as Deal and others (1989) found no significant lateral variation in moisture content for any of the stratigraphic units exposed in the excavations.

Two explanations have been offered for the brine seepage observations (Deal and others, 1991b, Section 2.9): (1) The longer holes are tapping an area that is not dewatered, because they extend past the relatively old W170 drift DRZ. As a result, they may only tap about 100 ft (30 m) of undisturbed salt (in this case, the one 50-ft (15-m) hole would still produce brine, because it was drilled from a young excavation where a significant DRZ had not yet developed), and (2) Brine flows preferentially from the clay units, so the clay at the top and bottom of the orange band may be the only significant source of brine. Therefore, only the four holes (OH20, OH23, OH26, and OH45) that cut the orange band accumulate brine. Evidence presented in this report suggests that the second explanation is the more likely one.

2.6 Air Intake Shaft

The Air Intake Shaft (AIS) was inspected for evidence of brine inflow. The entire length of the shaft was viewed from the man cage, and photographs were taken of various intervals. Evidence of weep was noted, mainly in the form of salt encrustations. Appendix C provides details of the AIS inspection and includes photographs of some of the weep surfaces.

Salt encrustations, or weeps, are more common at depths below 1,500 ft, about the midpoint of the Salado Formation exposed within the AIS. Many of the weeps are stratigraphically controlled by bedding plains, as indicated by encrustations at single horizons. Most of the zones of weeping are associated with argillaceous halite; however, some weeps occur at the claystones underlying sulfate marker beds. There are few weeps within the purer halite beds deposited subaqueously, and only one wet surface (MB 103) was observed.

The anhydrite surfaces are typically dry and free of salt encrustations, indicating that no significant amount of brine flows through them to the shaft.

2.7 Discussion of Data Acquisition and Analysis

Several different sampling techniques have been used in an attempt to uniformly collect the very small amounts of brine that seep into the hole between sampling rounds; each technique has unique problems. The change in sampling methods and difficulties in sampling techniques was discussed in detail by Deal and others (1991b) and is sometimes reflected as apparent variations in seepage rates (Appendix B).

To compensate for sampling-induced apparent variations in seepage rates, the graphs of the seepage data presented in Appendix B have been smoothed using an 11-point moving average (the average of the data point and the five points on each side of the data point). At the beginning and end of each curve, the trend is distorted by the smoothing function, because the eleven point moving average reduces to a 9, 7, 5, 3 average and actual data point on both ends of the curve for a more accurate graphical representation of the seepage trends. There are slight differences between the curves presented in this report and in previous BSEP reports, because a different software package was used to create the plots.

3.0 Statistical Analysis of the BSEP Brines

3.1 Introduction

A major objective of the BSEP has been to characterize the composition of brine that seeps into the WIPP excavations from the Salado Formation. Statistical analysis of BSEP geochemical data has been used to approximate the chemistry of typical Salado Formation brine that may come into contact with waste after closure of the WIPP repository. The analysis of BSEP brine compositions contained here updates previously analysis (Deal and others 1989, 1991a, 1991b, and 1993).

The geochemistry of brines recovered from the WIPP repository horizon have been the subject of numerous studies (Stein and Krumhansl, 1986; Krumhansl and Stockman, 1987; Stein and Krumhansl, 1988; Deal and others 1989; Abitz and others, 1990; Krumhansl and others, 1991; Deal and others, 1991b; Deal and others, 1993). Both the major and trace-element compositions of the WIPP brines suggest that the brine originated from evaporating seawater, as substantiated by the high magnesium, potassium, and bromine content of the brines, which differs from the composition of a brine formed by dissolving the Salado evaporites in infiltrating groundwater (Deal and others, 1991b). The brine chemistry indicates that seawater has precipitated carbonate minerals, anhydrite, and halite and has been further modified by diagenetic reactions with gypsum, magnesite, polyhalite, and clay minerals. The major-element compositions of brines recovered from BSEP holes are distinct from fluid inclusion in WIPP halite (Stein and Krumhansl, 1988), implying that the brine recovered from the drillholes is mostly intergranular fluid, rather than fluid released by migration of fluid inclusions to grain boundaries in response to stress relief.

During 1992, 40 brine samples were recovered from 18 drillholes in the Salado Formation at the repository horizon. These brine samples were analyzed for up to 27 chemical parameters by Rust Geotech (formerly UNC Geotech of Grand Junction, Colorado). Brine chemistry data for all samples collected from 1987 to 1992 are tabulated in Appendix D.

The statistical analysis of BSEP brine compositions includes a measure of the central tendency of each measured parameter for each drillhole. In order to calculate a central tendency, such as a mean or a median, the following issues were considered:

- Evaluation of data sources
- Analysis of data for the presence of temporal trends
- Handling of duplicate analysis
- Determination of the type of statistical distributions
- Handling of values less than the detection limit of the laboratory equipment
- Rejection of outliers.

The statistical analysis also includes the calculation of an average brine chemistry for the repository horizon. This average brine chemistry was determined by grouping data together from drillholes that sample brine from below and within the repository horizon. Data were tested using an analysis-of-variance calculation to determine if it is statistically valid to group the analyses from different drillholes together.

3.2 Sources of Data

BSEP brine samples have been collected over five years from several drillholes at various locations in the underground. Many of the drillholes discussed in previous BSEP reports are no longer producing brine, and some new holes were added to sampling locations. Only drillholes that produced a significant volume of brine since sampling began in 1987 are considered in these calculations. Additionally, some BSEP drillholes have been contaminated by water spread for dust control and floor consolidation. This report only discusses data from those drillholes that were not considered to have been contaminated with waters used for dust control (spread waters), drilling fluids, or synthetic brine used in Room J. These drillholes, sampled in 1992, are located in areas where contaminating brines have not been spread (Rooms A1, A2, A3, B, and G) or in subhorizontal holes located where water spread on floors could not enter them (Table 3-1).

Only geochemical data from Rust Geotech were used in the statistical analysis. Previous sampling rounds were analyzed by both Rust Geotech and IT analytical laboratories. Comparisons of geochemical data analyzed by these two laboratories are misleading, because differences in laboratory technique produce slightly different values for parameters analyzed (Deal and others, 1991b).

3.3 Temporal Trends

In order to perform a statistical analysis of the brine compositions, it was necessary to first determine if brine chemistry changes as a function of time. Changes in brine chemistry with

Table 3-1
BSEP Drillholes Sampled for Brine between 1987 and 1993

Downholes	Suspect ^a Downholes	Upholes	Subhorizontal Holes
A1X01*	DH28	A1X02	OH20
A2X01*	DH30	OH47	OH23*
A3X01*	DH32		OH26*
BX01*	DH34		OH45*
DH36*	DHP402A		
DH38*	G090		
DH40	GSEEP		
DH42*	H090		
DH42A*	L1X00		
NG252	OH62		
OH46	OH63		
	OH66		
	OH67		

^aSuspect holes may be contaminated with water spread on drift floor for construction purposes.

*Drillholes used for statistical analysis.

time may indicate that physical processes such as evaporation or mixing are occurring. Brine chemistry affected by these processes may not be reflective of in situ conditions.

Chemical parameters that are nonsolubility-constrained (i.e., not controlled by precipitation of evaporite minerals) will behave similarly when evaporation occurs and will become concentrated in the brine. Likewise, mixing of brine with spread waters will also change the concentration of the nonsolubility constrained parameters with time. These include boron, bromide, magnesium, and potassium. Parameters that are controlled by solubility and precipitate with evaporite minerals included sodium, chloride, calcium, and sulfate.

Temporal trends were analyzed by plotting the concentration data against the sampling date for the downholes, upholes, and subhorizontal holes. No temporal trends were evident for nonsolubility-constrained parameters from the downholes and the subhorizontal holes. Thus, brine from downholes and subhorizontal holes have not been evaporated or mixed with other

waters. However, Figure 3-1 shows that uphole A1X02 is affected by evaporation. Magnesium, boron, and bromine display similar changes in concentration with time. Concentrations for these elements in uphole A2X01 all increase and decrease in the same samples. Concentrations of potassium, however, are not similar to magnesium, boron, and bromine in the latest sampling rounds. This suggests that perhaps some potassium is substituting into halite, which is precipitating from the brine during evaporation. Because magnesium, boron, and bromine have similar changes in concentrations with time and because the ratio of these parameters with each other is constant with time, brine from uphole A1X02 has undergone various amounts of evaporation between sampling events. It has been previously suspected that partial evaporation has altered the concentrations in the upholes (Deal and others, 1991b).

3.4 Duplicate Analysis

In order to measure the concentration of dissolved constituents in brine samples from the repository horizon, it was necessary for the analytical laboratories to dilute the samples. Because dilution factors were high for the BSEP brines, measurement errors sometimes occurred, particularly in earlier sampling rounds. Consequently, duplicate analyses were performed on the brine samples. Duplicate analyses were used to identify analytical errors and to indicate how precisely the concentrations can be measured.

For the purposes of the statistical analysis, the concentration values for duplicate analyses were averaged. If one of the duplicate samples was obviously erroneous (i.e., an obvious data outlier), then only the single best value of the duplicates was included. Additionally, if one of the duplicates had a value below detection limits and the other duplicate had a detectable concentration, then only the detected value was chosen for statistics.

3.5 Determination of Statistical Distributions

The first step in data analysis is to determine the distribution of each data set. In this case, a data set would consist of all data collected for a particular parameter in a particular drillhole. The specific statistical procedure used to analyze the data and the methods used to identify outliers are dependent on the assumed distributions of the data sets. If a data set was determined to be normally distributed, then a mean and a standard deviation were calculated. If a data set was not normal, then nonparametric techniques were used. For the purposes of this report, the term "nonparametric techniques" refer to statistical procedures that do not

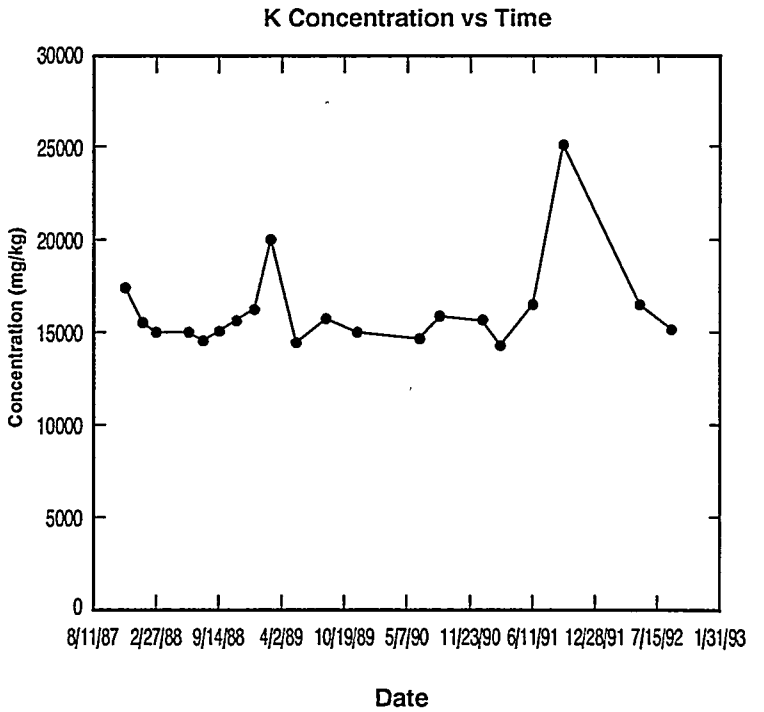
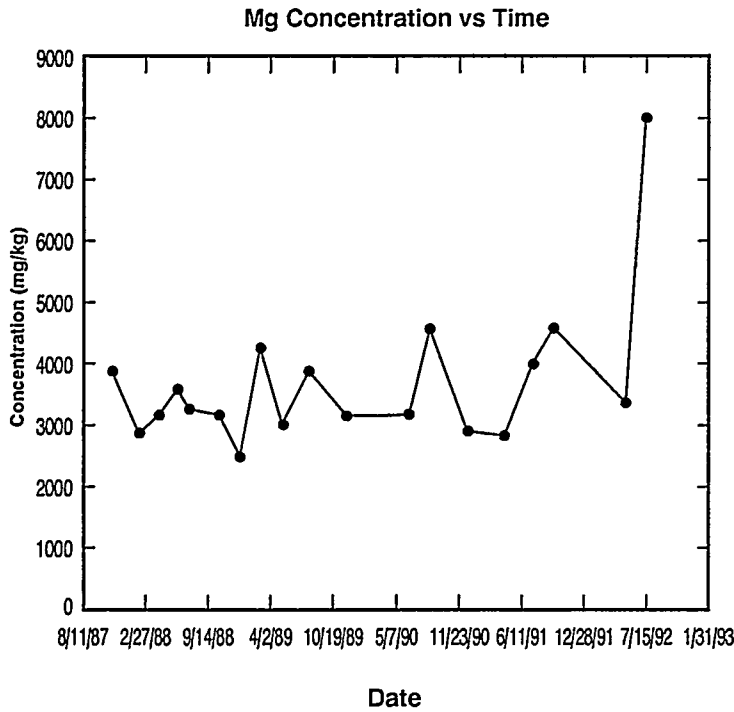
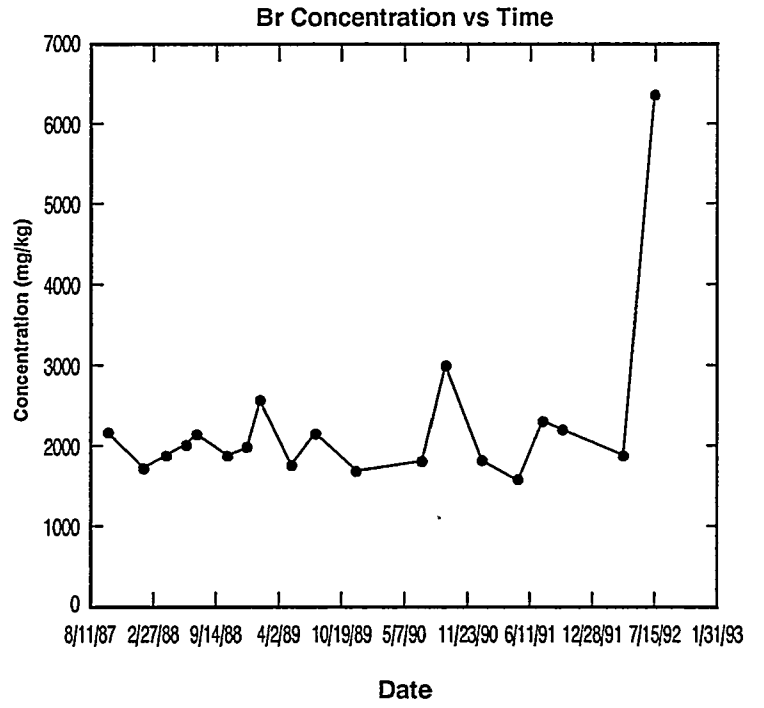
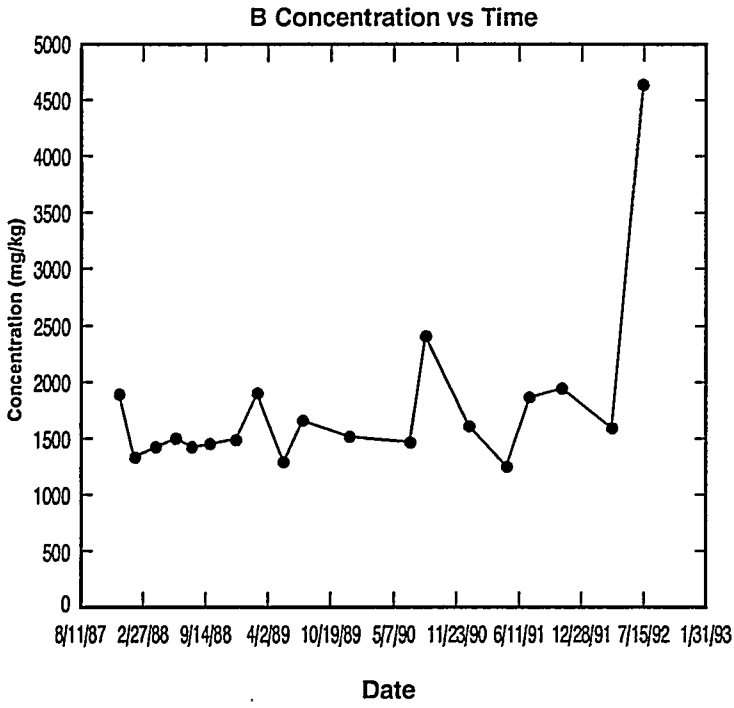

Figure 3-1
Uphole A1X02 Concentration vs. Time
for B, Br, Mg, and K

require the data to fit any particular distribution. Only a median was reported for a nonparametric data set.

For each drillhole, 27 parameters were analyzed. Thus, there are 27 data sets for each drillhole, and there are 11 drillholes that were considered in this statistical analysis (Table 3-1) for a total of 297 data sets. Because there are so many data sets, it was impractical to test each one for normality. Consequently, only the nonsolubility-constrained parameters (boron, bromine, magnesium, and potassium) were tested for normality.

A Kolmogorov-Smirnov statistical test (Kennedy and Neville, 1986) for the 95 percent confidence level was applied to the data from each drillhole (Table 3-1) for each nonsolubility-constrained parameter to test for normality. This statistical test determines how well a set of observations fit a theoretical normal distribution by calculating the maximum distance between the cumulative distribution functions of the sample and the theoretical normal distribution. If the distance is too large, the hypothesis that the theoretical distribution fits the observed distribution is rejected. In all cases, the geochemical data collected from 1987 to 1993 for each nonsolubility-constrained parameter in each drillhole were normally distributed. After it was determined that the data from nonsolubility-constrained parameters were normally distributed, it was assumed that data sets for other parameters were also normally distributed.

Because each data set was not rigorously tested to determine if it was normally distributed, the coefficient of variation was also calculated for each data set assumed to be normal. The coefficient of variation (V) is defined by Kennedy and Neville (1986) as:

$$V = S/X * 100$$

where

S = Population standard deviation

X = Population mean.

The coefficient of variation expresses the dispersion of samples on a percentage basis. If the coefficient of variation is larger than approximately 10 percent, the assumption of normality for that particular data set is questionable. Thus, data sets with a coefficient of variation larger than 10 percent were tested for normality using the Kolmogorov-Smirnov test described above. If a data set had a large coefficient of variation and did not pass the Kolmogorov-

Smirnov test at the 95 percent confidence level, the distribution was assumed to be nonparametric, and only a median was reported.

3.6 Handling of Values

A certain proportion of the values presented in this report were reported as being below the detection limits of the analytical equipment. The U.S. Environmental Protection Agency (EPA) guidance (EPA, 1989 [EPA/530-SW-89-026]) for dealing with such values was used for this report. If the data set was normal and if less than 15 percent of the values were below detection limits, the nondetected values were replaced with a value equal to one half of the detection limit, and a mean and a standard deviation were calculated. This approach should not have introduced a large bias, because the proportion of nondetected values was low, and the difference between the detection limit and zero is small using modern analytical methods.

If the percentage of nondetected values were greater than 15 percent of the data set, those values were replaced with one half of the detection limit, and a median was calculated. The percentage of those values below the detection limit was also reported. Some of the data sets contain older data points that have considerably higher detection limits than more recent data. In fact, the detection limits for some older below-detection-limit data points are higher than the median of the population. These "high nondetect" data points were deleted from the data sets because they did not add any additional information and because including them with an arbitrarily assigned value of one half the detection limit would have added a bias to the calculated median.

3.7 Rejection of Outliers

Outliers are data points whose values are anomalously high or low in relation to the rest of the data set. The following are possible reasons for outliers:

- Improper sampling, analytical error, or laboratory contamination
- Errors in transcription of data values, decimal points, or units
- The presence of foreign substances or contamination in the sample
- A true natural value that is unusually high.

Each data set that was assumed to be normally distributed was screened for outliers using the EPA-recommended technique (EPA, 1989 [EPA/530-SW-89-026]), which is based on American Society for Testing and Materials (ASTM) Procedure E178-80. This procedure determines if there is statistical evidence that an observation which appears extreme does not

fit the distribution of the rest of the data. The procedure calculates the statistic T_n , which is defined as:

$$T_n = (X_n - X)/S$$

where

X_n = Observation

X = Population mean

S = Population standard deviation.

The calculated T_n value is then compared to a table of one-sided critical values for the appropriate significance level (upper 5 percent) and sample size (a suitable table is provided in EPA, 1989 [EPA/530-SW-89-026]). The T_n statistic differs from the standard "t" critical value distribution in that the T_n statistic is calculated from the entire population, including the suspected outliers. The standard "t" critical values are used to determine if a new sample value (not yet included in the population statistics) is an outlier.

If the T_n value for the suspect data is greater than the critical value from the table, then there is evidence that the value is a statistical outlier. Because of symmetry considerations, the above equation can be applied to a suspected minimum outlier value by taking the absolute value of T_n equation and comparing it with the tabulated values. Both minimum and maximum suspected outliers can be screened from the data sets.

The specific procedure used in this investigation for the identification of outliers is as follows:

- Normal data sets. Calculate a mean and standard deviation. Calculate a T_n statistic and compare to the table. If outliers are confirmed, delete them from the data set and recalculate the mean standard deviation.
- Nonparametric data sets. The screening using the T_n statistic is not applied. The T_n procedure described above is based on an assumption of a normal distribution in which one can calculate the probability of a given value being a member of a population. Nonparametric data sets are not predictable in this sense.

For all data sets that were assumed to be normal, outliers (if present) were removed from the data sets, and the average and the standard deviation for each parameter were calculated. If a data set was nonparametric, the median, the number of nondetects, and the percentage of

nondetects was determined. Values of the mean or median and standard deviation for each drillhole are given in Table 3-2.

3.8 Average Brine Chemistry

An average brine chemistry was determined by grouping data together from drillholes used to sample brine from the repository horizon. To check the validity of grouping these drillholes together, a one-way analysis of variance (ANOVA) calculation was performed.

Drillholes were separated into two different groupings, based upon whether or not they sampled stratigraphy within the repository horizon. One group consisted of drillholes DH36, DH38, DH42, and DH42A. These drillholes are used to sample brine encountered only in stratigraphy beneath the repository horizon. The second group consisted of drillholes A1X01, A2X01, A3X01, BX01, OH23, OH26, and OH45. These drillholes are used to sample brine encountered in stratigraphy within and below the repository horizon and are the most representative of overall repository brine chemistry. Figure 2-3 shows the stratigraphic locations of the down holes. The subhorizontal holes start just above the orange band (Figure 2-2, Detail 2) and end below it, just above the floor of the drift. The subhorizontal holes are primarily to sample brine from the clays above and below the orange band.

A one-way ANOVA was performed for each of the nonsolubility-limited parameters (boron, bromine, potassium, and magnesium) to determine if the data for a particular parameter from the drillholes in their respective groupings were part of the same statistical population. ANOVA is a general method in which the total statistical variation in a set of data is considered in order to simultaneously test the differences between subpopulation means at a certain confidence level to determine if the subpopulations can be grouped. In this case, the subpopulation means consisted of a given parameter from each evaluated drillhole (listed in Table 3-2). The ANOVA calculation was performed for the 95 percent confidence level.

ANOVA calculations performed on the combined data from drillholes A1X01, A2X01, A3X01, BX01, OH23, OH26, and OH45 showed that analyses for boron, bromine, and potassium are members of the same population (i.e., they have significance at the 95 percent confidence level). Magnesium analyses for these drillholes did not have significance at the 95 percent confidence level. It is unclear why magnesium failed the ANOVA test for

Table 3-2
Simple Statistics for BSEP Analyses
(in mg/L)

	Downhole A1X01						Downhole A2X01						
	N	X	S	Median	No. ND	% ND	N	X	S	Median	No. ND	% ND	
SG	14	1.23	0.01				SG	13	1.23	0.01			
TDS	13*	376000	10000				TDS	12*	400,000	8000			
pH	14	6.1					pH	12*	6.1				
ALK	14	980	33				ALK	13	989	88			
TIC	13*	5.6	4.5				TIC	13	26.4	26.7			
TOC	12	22	20				TOC	10	53	49			
Br-	14	1500	60				Br-	12*	1510	40			
Cl-	14	193000	2000				Cl-	12*	200,000	2000			
F-	14	6	1				F-	13	7	1			
I-	14	14.6	2.6				I-	13	13.5	1.0			
NH ₄ ⁺	14	150	13				NH ₄ ⁺	12*	148	10			
NO ₃ ⁻	10			0.8	3	30	NO ₃ ⁻	9			0.8	3	33
P	8			<0.1	7	88	P	7			<0.1	6	86
SO ₄ ⁻²	14	17500	600				SO ₄ ⁻²	13	17300	1000			
Al	13*	0.18	0.16				Al	12			0.13	2	17
As	13*	0.003	0.004				As	13			<0.001	8	62
B	14	1460	110				B	13	1430	100			
Ba	13*	0.03	0.02				Ba	13	0.07	0.04			
Ca	13*	265	32				Ca	13	290	49			
Cs	9	0.36	0.04				Cs	7	0.37	0.04			
Fe	14			<0.5	8	57	Fe	13	17.1	16.3			
K	14	15900	800				K	12*	16100	500			
Mg	14	23300	1000				Mg	13	23100	1700			
Mn	14	1.6	0.2				Mn	13	1.8	0.1			
Na	14	79000	2000				Na	12*	78700	2300			
Rb	5	16.5	1.2				Rb	3	16.1	1.5			
Si	13*	1.4	0.4				Si	13	1.5	1.2			
Sr	13*	1.7	0.1				Sr	12*	1.0	0.2			

*Outlier values omitted in statistical calculations.

N = Number of samples.

X = Mean.

S = Standard deviation.

ND = Not detected.

Table 3-2 (Continued)
Simple Statistics for BSEP Analyses
 (in mg/L)

Downhole A3X01							Downhole BX01						
	N	X	S	Median	No. ND	%ND		N	X	S	Median	No. ND	% ND
SG	18	1.22	0.01				SG	17	1.22	0.01			
TDS	17*	374000	14000				TDS	16*	400,000	12000			
pH	17*	6.1					pH	17	6				
ALK	18	980	41				ALK	17	873	31			
TIC	18			4.8	1	6	TIC	16*	7.1	7.2			
TOC	14*	29	17				TOC	14	27	19			
Br-	18	1490	70				Br-	17	1470	60			
Cl-	18	192000	5000				Cl-	17	200,000	4000			
F-	18	7	1				F-	16*	7	1			
I-	17*	14.2	2.8				I-	17	14.0	1.6			
NH ₄ ⁺	18	150	17				NH ₄ ⁺	17	150	15			
NO ₃ ⁻	14			0.7	4	29	NO ₃ ⁻	15			0.7	5	33
P	14			<0.1	13	93	P	11			<0.1	11	100
SO ₄ ⁻²	18	16900	900				SO ₄ ⁻²	17	17100	700			
Al	18			0.08	8	44	Al	17			0.08	6	35
As	18			0.002	4	22	As	16*	0.002	0.001			
B	18	1490	120				B	17	1470	100			
Ba	18	0.05	0.02				Ba	17	0.04	0.02			
Ca	18	273	32				Ca	17	270	23			
Cs	13	0.36	0.03				Cs	12	0.34	0.04			
Fe	18			<0.5	10	56	Fe	17			0.7	8	47
K	18	15700	800				K	17	16100	800			
Mg	18	23200	1300				Mg	17	22500	1100			
Mn	18	1.5	0.1				Mn	16*	1.3	0.2			
Na	17*	78300	2000				Na	17	79800	1700			
Rb	8*	15.9	0.6				Rb	8	15.8	1.0			
Si	17*	1.7	0.3				Si	16*	1.6	0.8			
Sr	17*	1.9	0.2				Sr	17	2.0	0.2			

*Outlier values omitted in statistical calculations.

N = Number of samples.

X = Mean.

S = Standard deviation.

ND = Not detected.

Table 3-2 (Continued)
Simple Statistics for BSEP Analyses
 (in mg/L)

OH23-horizontal hole							OH26-horizontal hole						
	N	X	S	Median	No. ND	% ND		N	X	S	Median	No. ND	% ND
SG	15	1.22	0.01				SG	12	1.22	0.01			
TDS	14*	373000	1500				TDS	12	400,000	15000			
pH	15	6					pH	12	6				
ALK	15	716	87				ALK	11*	731	38			
TIC	15	4.0	1.3				TIC	11*	3.8	0.7			
TOC	15	97	78				TOC	12	70	25			
Br-	15	1520	60				Br-	12	1490	30			
Cl-	15	193000	3000				Cl-	12	200,000	3000			
F-	15	4	1				F-	12	4	1			
I-	14*	16.3	5.0				I-	11*	16.0	3.0			
NH ₄ ⁺	15	147	14				NH ₄ ⁺	12	144	18			
NO ₃ ⁻	15			1	3	20	NO ₃ ⁻	12	0.9	0.3			
P	15			<0.1	9	60	P	12			0.1	3	25
SO ₄ ⁻²	15	16800	900				SO ₄ ⁻²	12	16500	800			
Al	15	0.13	0.08				Al	12			0.15	2	17
As	14*			0.002	0	0	As	12			0.001	5	42
B	14*	1450	60				B	12	1400	110			
Ba	14*	0.06	0.02				Ba	12	0.07	0.03			
Ca	15	303	36				Ca	12	295	32			
Cs	14*	0.29	0.03				Cs	12	0.29	0.03			
Fe	15			<0.5	15	100	Fe	12			<0.5	12	100
K	15	15900	900				K	12	15300	600			
Mg	15	22700	1500				Mg	12	22100	1100			
Mn	15	2.0	0.4				Mn	12	1.6	0.1			
Na	15	79400	1900				Na	12	79200	2700			
Rb	9	15.6	1.1				Rb	8*	15.2	0.7			
Si	15	1.9	0.7				Si	11*	1.2	0.4			
Sr	15	1.1	0.3				Sr	11*	1.0	0.2			

*Outlier values omitted in statistical calculations.

N = Number of samples.

X = Mean.

S = Standard deviation.

ND = Not detected.

Table 3-2 (Continued)
Simple Statistics for BSEP Analyses
 (in mg/L)

OH45-horizontal hole							Downhole DH36						
	N	X	S	Median	No. ND	% ND		N	X	S	Median	No. ND	% ND
SG	6*	1.22	0.01				SG	20	1.22	0.01			
TDS	6*	372000	14000				TDS	20	400,000	10000			
pH	7	6.2					pH	19*	6.1				
ALK	6*	856	50				ALK	19*	843	17			
TIC	7	5.5	2.4				TIC	18			5.2	0	0
TOC	7	91	28				TOC	15	23	17			
Br-	6*	1550	60				Br-	19*	1430	70			
Cl-	6*	193000	5000				Cl-	20	200,000	3000			
F-	7	5	1				F-	20	5	1			
I-	7	16.2	3.9				I-	17*	15.4	1.8			
NH ₄ ⁺	7	145	23				NH ₄ ⁺	17*	164	17			
NO ₃ ⁻	7	1.0	0.3				NO ₃ ⁻	16			1.0	6	38
P	7			0.1	2	29	P	11			<0.1	10	91
SO ₄ ⁻²	6*	16400	600				SO ₄ ⁻²	20	16300	600			
Al	7			0.06	3	43	Al	20			0.19	5	25
As	7	0.002	0.001				As	20	0.010	0.004			
B	7	1350	230				B	18	1520	110			
Ba	7	0.08	0.03				Ba	19	0.04	0.03			
Ca	7	289	62				Ca	20	322	23			
Cs	7	0.25	0.03				Cs	12	0.27	0.03			
Fe	7			<0.5	7	100	Fe	20			<0.5	14	70
K	6*	16100	1000				K	20	17900	800			
Mg	6*	21100	900				Mg	20	18600	900			
Mn	6*	1.5	0.1				Mn	20	1.0	0.1			
Na	6*	78900	2400				Na	20	85900	2000			
Rb	4*	15.3	0.3				Rb	8	14.8	0.6			
Si	6	1.3	0.4				Si	20	2.6	1.0			
Sr	7	2.5	0.6				Sr	20	1.3	0.1			

*Outlier values omitted in statistical calculations.
 N = Number of samples.
 X = Mean.
 S = Standard deviation.
 ND = Not detected.

Table 3-2 (Continued)
Simple Statistics for BSEP Analyses
 (in mg/L)

	Downhole DH38						Downhole DH42						
	N	X	S	Median	No. ND	% ND	N	X	S	Median	No. ND	% ND	
SG	20	1.22	0.01				SG	16	1.23	0.01			
TDS	20	371000	9000				TDS	15*	400,000	5000			
pH	19*	6.2					pH	15*	6.3				
ALK	19	939	68				ALK	15*	927	33			
TIC	19			6.1	0	0	TIC	16			6.1	0	0
TOC	16	29	21				TOC	13	36	17			
Br-	19*	1410	60				Br-	16	1410	60			
Cl-	20	193000	4000				Cl-	16	200,000	4000			
F-	19*	5	1				F-	16	4	1			
I-	18*	16.3	2.3				I-	15*	16.0	1.8			
NH ₄ ⁺	19	165	12				NH ₄ ⁺	16	169	16			
NO ₃ ⁻	16			0.7	3	19	NO ₃ ⁻	14			1.0	2	14
P	13			<0.1	9	69	P	9			<0.1	5	56
SO ₄ ⁻²	19*	15800	600				SO ₄ ⁻²	16	15800	800			
Al	20			0.20	7	35	Al	16			0.1	6	38
As	20			0.004	4	20	As	16	0.005	0.002			
B	19	1510	90				B	16	1490	100			
Ba	19*	0.03	0.01				Ba	15*	0.04	0.02			
Ca	20	317	24				Ca	15*	319	25			
Cs	13	0.26	0.03				Cs	9*	0.26	0.02			
Fe	20			<0.5	17	85	Fe	16			<0.5	9	56
K	20	18000	700				K	16	17800	900			
Mg	19*	18200	800				Mg	15*	17800	400			
Mn	20	1.0	0.1				Mn	15*	1.1	0.1			
Na	20	85700	2000				Na	16	86400	1500			
Rb	9	14.4	0.7				Rb	7*	14.0	0.4			
Si	20	2.4	0.8				Si	15*	2.6	1.3			
Sr	18*	0.8	0.1				Sr	15*	0.9	0.2			

*Outlier values omitted in statistical calculations.

N = Number of samples.

X = Mean.

S = Standard deviation.

ND = Not detected.

Table 3-2 (Continued)
Simple Statistics for BSEP Analyses
 (in mg/L)

Downhole DH42A						
	N	X	S	Median	No.ND	%ND
SG	20	1.23	0.01			
TDS	20	372000	9000			
pH	19*	6.2				
ALK	19	882	39			
TIC	17*	5.0	1.2			
TOC	15			20	3	20
Br-	19*	1400	50			
Cl-	20	194000	3000			
F-	20	4	1			
I-	18	16.3	3.8			
NH ₄ ⁺	17*	174	17			
NO ₃ ⁻	16			1.0	5	31
P	11			<0.1	9	82
SO ₄ ⁻²	19*	15700	600			
Al	20			0.12	7	35
As	20			0.004	3	15
B	18	1480	110			
Ba	19	0.03	0.02			
Ca	20	322	27			
Cs	11*	0.24	0.03			
Fe	20			<0.5	15	75
K	20	18200	800			
Mg	20	17700	900			
Mn	20	1.0	0.1			
Na	20	87100	2000			
Rb	8	14.1	0.1			
Si	20	2.5	0.7			
Sr	20	0.8	0.1			

*Outlier values omitted in statistical calculations.

N = Number of samples.

X = Mean.

S = Standard deviation.

ND = Not detected.

these drillholes since the accuracy and precision for the magnesium measurements are similar to the other nonsolubility-constrained parameters.

ANOVA calculations were also performed on the data from drillholes DH36, DH38, DH42, and DH42A that sampled the lower stratigraphic units below the repository horizon. ANOVA calculations indicated that geochemical analyses for boron, bromine, and potassium may be grouped together for these drillholes. Again, magnesium analyses for these drillholes did not have significance at the 95 percent confidence level. In addition to the ANOVA calculation, means plots were also produced. Means plots were created using a Tukey's honest significant differences method at a 95 percent confidence level. Means plots showed the mean of each data set as well as the upper and lower 95th confidence interval of each individual population. Means plots for the nonsolubility-limited parameters indicated the two distinct groupings of drillholes mentioned above (Figure 3-2). Means plots for bromine, potassium, and magnesium show the greatest differences between the two groups of drillholes (Figure 3-2).

Because data from drillholes A1X01, A2X01, A3X01, BX01, OH23, OH26, and OH45 for the nonsolubility-limited parameters (boron, bromine, and potassium) comprise a statistically significant population, it is reasonable to assume that data for other parameters in these drillholes can also form a statistically significant population. As mentioned previously, data from drillholes A1X01, A2X01, A3X01, BX01, OH23, OH26, and OH45 are most representative of the repository brine chemistry because these drillholes sample brine encountered in the stratigraphy within and below the repository horizon. Since data from these drillholes can be grouped together, a measure of the central tendency for each parameter can be calculated; however, it was necessary to determine which type of data distribution each parameter possesses. The data was normally distributed for the nonsolubility-limited parameters. This was achieved by again applying the Kolmogorov-Smirnov test for normality to the combined data from each of the drillholes mentioned above. It was then assumed that other parameters were also normally distributed, as long as the data distributions for each drillhole were also normal. With this assumption, a mean and a standard deviation were calculated for each parameter. If the data distributions for individual drillholes were nonparametric, then only a median was calculated. The average representative brine chemistry is given in Table 3-3.

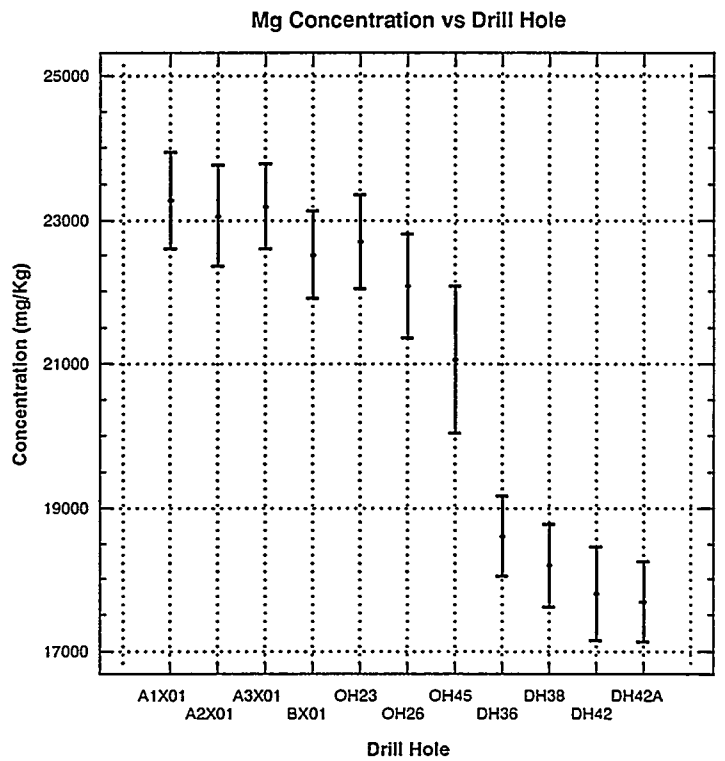
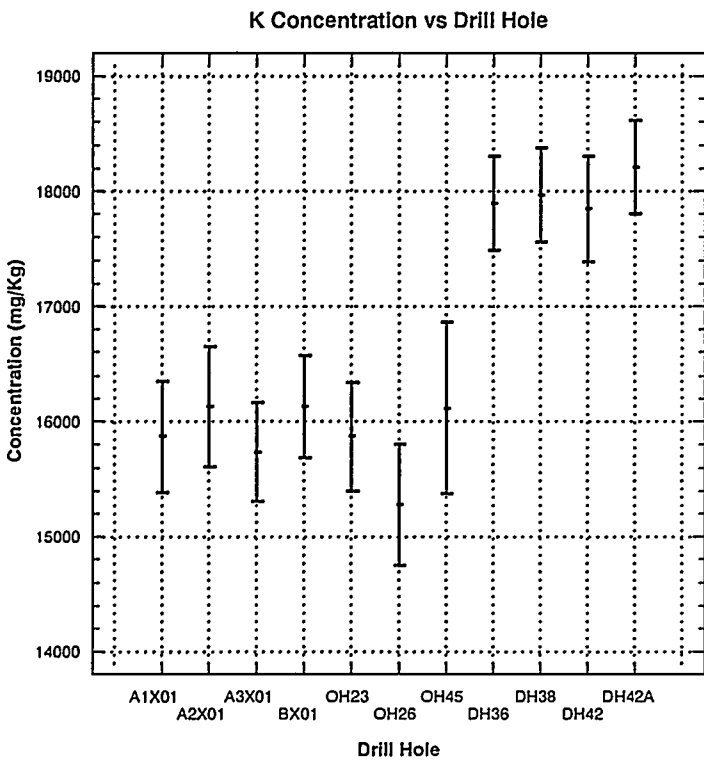
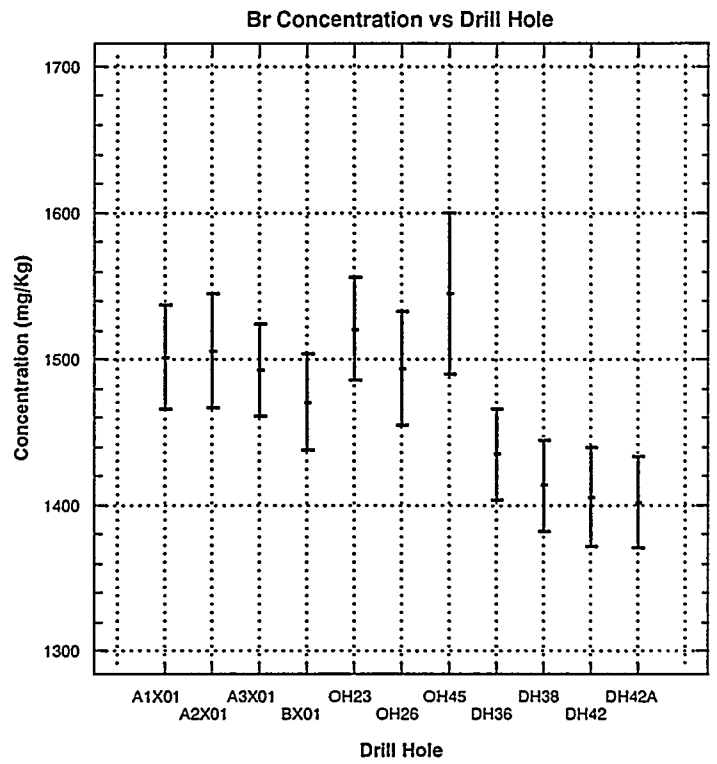
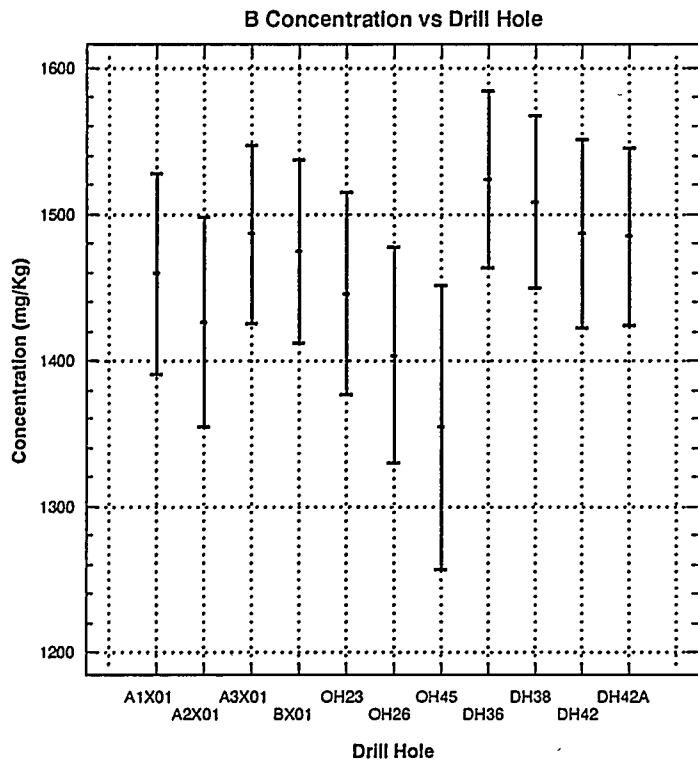

Figure 3-2
Means Plots for BSEP Drill Holes for B, Br, K, and Mg

Table 3-3
Average Composition of Salado Formation Brine

	N	X	S	Median	No. ND	% ND
SG	95	1.22	0.01			
TDS	90	374000	13000			
pH	94	6.1				
ALK	94	883	123			
TIC	96			4.6	3	3
TOC	84	54	50			
Br-	94	1500	60			
Cl-	94	193000	4000			
F-	95	6	1			
I-	93	14.8	3.1			
NH ₄ ⁺	95	148	16			
NO ₃ ⁻	82			0.8	19	23
P	74			<0.1	51	69
SO ₄ ⁻²	95	17000	900			
Al	95			0.10	21	22
As	96			0.002	19	20
B	95	1450	120			
Ba	94	0.05	0.03			
Ca	95	282	38			
Cs	74	0.32	0.05			
Fe	96			<0.5	61	64
K	94	15900	800			
Mg	95	22700	1400			
Mn	94	1.6	0.3			
Na	93	79100	2100			
Rb	45	15.7	1.0			
Si	91	1.6	0.7			
Sr	92	1.6	0.6			

N = Number of samples.

M = Mean

S = Standard deviation.

ND = Not detected.

3.9 Composition of Non-Salado Brine from the WIPP Underground

The BSEP Brine Chemistry database also contains data on some non-Salado brines that have been encountered in the WIPP excavations. The most important of these are water from the Culebra Dolomite that has been piped to the repository horizon through temporary drains in the shafts, the brine in the AIS sump, and artificial brine produced commercially (B&E Artificial Brine).

Previously unreported data are included in Part II of Appendix D and summarized in Table 3-4.

The sample for the Culebra brine was collected on March 3, 1990, at the discharge of the AIS drain on the north side of the AIS station. The Sr concentration was found to be 11 mg/l in this sample, which is considered a low value for Culebra water. The data collected for the Culebra in the vicinity of the WIPP site by the Water Quality Sampling Program show that there is quite a variation in the Sr values. Data from an individual location (well H-03b3) range between 12 and 30 mg/l as sampling is repeated (DOE/WIPP 92-007, 1992).

Underground brine samples with a relatively high (more than 3 mg/l) suggest the possibility of contamination by Culebra water or of partial evaporation of the sample prior to laboratory analysis.

The water from the Culebra is collected in a sump at the AIS, where it dissolved additional salt from the Salado. The AIS sump brine was often used for construction purposes and has been the main source of underground brine contamination. The salinity of the water in the sump varies considerable from time to time, ranging from nearly unaltered Culebra water to a saturated brine. As a result, it is not appropriate to average the analyses for the sump brines, but rather to show great variations in the chemistry as is done in Table 3-4. The only way to determine a mixing curve for any given sample that is suspected of being contaminated would be to have performed an analyses of the actual batch of brine that was spread to cause that contamination. Such analyses was performed in August 1988 and reported in Deal and others (1989), Section 3.1.1.3.

3.10 Conclusions

Temporal trends for geochemical data collected as part of the BSEP were determined for uphole A1X02. Simultaneous changes in nonsolubility-constrained parameters indicated that evaporation had occurred in this drillhole. No temporal trends were evident in other

Table 3-4
Composition of Salado and Nonsalado Brines

	WIPP Repository Horizon	Culebra from AIS Drain	Culebra from AIS Sump	B & E Artificial Brine
SG	1.22	1.04	1.06 - 1.21	1.22
TDS	374,000	48,000	96,000 - 333,000	324,000
pH	6.1	8.1	7.1 - 8.2	6.6
ALK	883	113	116 - 177	191
TIC	4.6	73	78 - 113	190
TOC	54	10	5 - 91	31
Br-	1,500	28	35 - 90	23
Cl-	193,000	20,600	50,700 - 190,000	187,000
F-	6	1	<1 - 4	3
I-	14.8	0.2	<0.1 - 0.2	1.5
NH ₄ ⁺	148	0.34	0.33 - 4.5	0.31
NO ₃ ⁻	0.8	0.1	<1 - 10	4
P	<0.1	<0.1	<1	<0.3
SO ₄ ⁻²	17,000	8,200	6,200 - 11,000	3,600
Al	0.10	<0.05	0.17 - 2.4	<0.05
As	0.002	<0.001	0.002	0.003
B	1,450	35	12 - 31	2
Ba	0.05	0.03	0.07 - 2.4	0.1
Ca	282	822	669 - 989	1,520
Cs	0.32	NA	<0.01 - 0.02	0.02
Fe	<0.5	0.5	0.1 - 1.4	<0.5
K	15,900	376	496 - 3,210	11
Mg	22,700	568	629 - 1,630	43
Mn	1.6	<0.5	<0.1 - 0.4	<0.1
Na	79,100	15,800	32,600 - 121,000	120,000
Rb	15.7	NA	NA	NA
Si	1.6	3.8	3.3 - 8.6	50
Sr	1.6	11	14 - 33	24

drillholes. Data distributions were assumed for each parameter in each drillhole, duplicate analyses were averaged, outliers were removed, and simple statistics were calculated for each drillhole (Table 3-2).

Data from different drillholes were then grouped together. One group consisted of drillholes A1X01, A2X01, A3X01, BX01, OH23, OH26, and OH45. These drillholes are used to sample brine from stratigraphy located within and below the WIPP repository. A second group consisted of data from drillholes DH36, DH38, DH42, and DH42A. These drillholes are used to sample brine from stratigraphy located beneath the repository. An ANOVA calculation indicated two separate populations for the nonsolubility-limited geochemical parameters. Because brine recovered from drillholes A1X01, A2X01, A3X01, BX01, OH23, OH26, and OH45 are more representative of the repository horizon conditions, an average geochemical composition for brine from these drillholes was calculated (Table 3-3). This brine composition was the average representative brine composition for the repository horizon.

THIS PAGE INTENTIONALLY LEFT BLANK

4.0 Hydrologic Testing of the Fractured Part of the Disturbed Rock Zone Beneath the WIPP Excavations

The main objective of the Hydrologic Testing of the Fractured Part of the Disturbed Rock Zone Beneath the WIPP Excavations Program is to characterize the fracture system beneath the floor of the repository. The data resulting from this program will be used by Waste Isolation Division personnel to develop operational plans for predicting brine and gas movement through the fracture system. Additionally, the data obtained may be useful in refining the design of seals to be used within the repository and in assessing the long-term behavior of flow through the fractured zone.

As salt creeps into the WIPP underground excavations, macrofractures develop in the DRZ beneath the excavations (Bechtel, 1986; also, see review by Deal and Roggenthen, 1991). The fractures tend to concentrate in, but are not limited to, MB 139, which is about 1 m thick, lying 1 to 2 m below the floor of most of the WIPP excavations. The developing fracture systems may provide pathways for rapid movement of brine and gas (Deal and Case, 1987; Deal and others, 1989; Deal and others, 1991b) and are considered to be one of the most likely pathways for migration of constituents away from the waste storage panels. The hydrologic characteristics of the fractured zone must be understood to predict and, if necessary, modify the movement of fluids and constituents within MB 139 if a release occurred during operation of the facility.

In 1989, a hydraulic test of short duration was conducted in the DRZ beneath the floor of the intersection of the S90 and W620 drifts (Deal and others, 1991b). The results indicated that drawdown-type pump testing in the underlying fracture system could be performed successfully and could yield useful hydrologic data about the DRZ. After evaluating the results from the preliminary testing effort, a more comprehensive field testing program was developed, and hydraulic testing was implemented at two additional underground test sites.

This section summarizes the results of short-duration hydraulic tests conducted at the two additional sites. The original file report (Crawley and others, 1992) without the test appendices, is edited and presented as Appendix E.

The hydrologic testing areas were selected to evaluate various room and drift dimensions, excavation ages, areas where water was introduced for construction purposes, and areas

isolated from construction fluids. Three sites were selected for drilling and testing as part of this program because of their age, their physical characteristics, their relationship to other excavations, the existence of fractures, and exposure to long periods of water spread for construction purposes.

- Test Site No. 1 is at the intersection of the S90 and W620 drifts near the AIS. This site consists of 20 test holes drilled at the intersection and along the length of the S90 drift (Appendix E, Figure E-2-2). This test site was not accessible during this field investigation period, but was described in detail by Deal and others (1991a, Section 4).
- Test Site No. 2 is located in the E0 drift in the general area of N620. The site includes nine test holes drilled along the E0 drift (Appendix E, Figure E-2-2).
- Test Site No. 3 is located in the W170 drift immediately in front of the underground core storage room at S400. This site consists of 11 test holes drilled along the W170 drift and into the core storage room (Appendix E, Figure E-2-2).

Test results indicate that the significant fracture systems that yield water to test holes are restricted to MB 139. For the two sites tested during this reporting period, there appears to be separate, saturated, unconnected fracture systems of fairly low transmissivity. At the E0 test site, fracture systems that are connected are confined to the immediate intersection of the drift and alcove. For the W170 site, the intersection did not contain significant connected fractures. Based on the observed drawdown response to pumping, the area within the core storage room appeared to be underlain by a somewhat more connected fracture system. This condition could be influenced by the width of the individual excavations. The W170 drift, though much older, has a relatively narrow opening in comparison to the core storage room. These data indicate that excavation dimensions may have a more important role than age in fracture development.

The post-test fluid-level recovery observed at the test sites suggests that the fracture systems beneath these areas are limited, and the available fluid reservoirs are small. Although long-term fluid-level monitoring was not conducted as part of this field program, the data gathered indicate that pumping at these sites was dewatering the fracture systems.

The results of the pumping tests support the concept of limited, bounded fractured fluid reservoir that was developed during the 1989 testing program (Deal and others, 1991a). Data

analysis from the E0 test site showed clear changes in the slope of the plotted drawdown curves for some test holes, indicating the presence of nearby no-flow or low-permeability boundaries. Testing at the W170 site did not produce adequate data for aquifer test analysis.

The Jacob and Theis methods (Lohman, 1972) were used to determine transmissivity and storage coefficients for the first test at the E0 site. The calculated transmissivities for all holes were 0.7 to 9.9 ft²/day. Storage coefficients ranged from 0.00038 to 0.0034, indicating that the fracture system at the E0 site is partially confined.

Additional test sites should be developed to better define the nature of fracturing in areas other than the intersections of drifts and rooms. The E0 test site could be expanded to both the north and south of the present site to allow comparative testing. If the test site was expanded, the results of pump testing away from the drift and alcove intersection could be compared to the results produced by this study, and the effects of excavation geometry could be quantified. Additional testing should be conducted at the lowest possible flow rates for the longest time achievable, and fluid-level recovery should be monitored long-term.

THIS PAGE INTENTIONALLY LEFT BLANK

5.0 Numerical Modeling of Brine Seepage as a Result of Clay Compaction

5.1 Introduction

There appears to be enough moisture present in the clays within the Salado Formation to account for all the brine that is observed to seep into the WIPP excavations (Deal and others, 1993, Section 5; Deal and Bills, 1994). The excavation of WIPP rooms result in stress redistribution around those openings that can cause the consolidation of thin clays within the stratigraphic sequence. Additionally, the excavations (including drillholes) provide a sink at atmospheric pressure allowing brine to flow from the consolidating clays.

A series of order-of-magnitude calculations were made for this report (Appendix F) in order to numerically model clay consolidation and estimate the resultant brine seepage into the repository horizon.

5.2 Modeling Assumptions

The modeling assumptions are as follows:

- Stress redistribution results in a localized increase in stress that is far more significant in generating excess pore pressure than in near ground surface consolidation. The stress redistribution deforms the clay plastically generating an excess pore pressure of several megapascals (MPa) within the DRZ.
- Transient flow to the excavation or boundary dissipates the excess pore pressure within the clay layer.
- The rate of flow depends on the consolidation properties of the clay (hydraulic conductivity, compressibility, and porosity), the cross sectional area of the clay seams intercepting the excavation, and the extent of the DRZ.
- The tributary method predicts the resulting increase in total stress of 3 MPa. Consider that after 1,000 days (Deal and others, 1989, Section 5), the stress abutment zone extends out about 5 excavation diameters. The average diameter for the room is about 3 m.
- The compressibility of the clay is 10^{-7} Pa^{-1} corresponding to a clay of medium compressibility. The hydraulic conductivity of the clay is 10^{-8} cm/s . Under a change in effective stress of 3 MPa after consolidation is complete, the change in porosity is 30 percent.

5.3 Room Q

For the case of Room Q, the room has a radius of 1.5 m and a length of 100 m. Two thin clay seams occur, above and below the orange band. Both are about 3.5 mm thick (Deal and others, 1993, Table 4-3) and are modeled as a single clay 7 mm thick, centered in the room. In this case flow occurs linearly along the clay seams toward the room. From previous modeling analyses (Deal and others, 1989, Section 5), the stress abutment zone around Room Q will affect the clay seams out to a distance of about 9 m. No brine was collected from Room Q for the first 800 days (Howarth and others, 1994, Section 4.2.2.3). For this calculation, brine inflow was assumed to have begun as soon as Room Q was excavated, but because no records of brine volume were made for the first 800 days, the first 800 days of predicted seepage were subtracted from these calculations so that the plot (Appendix F, Fig. F-2-2) shows calculated inflow from 800 days to 25 years after excavation. The cumulative inflow 1,600 days after excavation was calculated to be about 300 L, slightly more than the 200 L that was observed (Howarth and others, 1994, Fig. 2). Calculated inflow rates after 1600 days are on the order of 0.3 L/day (Appendix F, Fig. F-2-2), close to the observed value of 0.17 L/day (Howarth and others, 1994, Fig. 3). The calculation shows that seepage ceases after about 25 years (Appendix F, Fig. F-2-2).

5.4 Standard WIPP Waste Storage Room

In order to estimate the amount of brine that might come in contact with waste stored at the WIPP after sealing and closure, a similar calculation was made for a standard waste storage room. A waste storage room was approximated as a circular opening 3.6 m in radius and 91.4 m long with an abutment zone extending 20 m into the salt from the wall of the room. Three clay layers are observed in the walls of the rooms, the two clays associated with the orange band that are exposed in Room Q (each about 3.5 mm thick), and clay F, which is about 10 mm thick (Deal and others, 1993, Table 4-3). For this calculation, the three clays were combined as a single clay 17 mm thick occurring at the mid-point of the room. This model predicts rapid initial inflow of about 2 L/day rapidly dropping to less than 0.5 L/day after about 10 years (Appendix F, Fig. F-3-2). This calculation shows that the pore pressure is completely depleted after about 100 years (Appendix F, Fig. F-3-2) and inflow then ceases. The total inflow would be about 9,000 L, much of which would be evaporated during excavation and emplacement of waste into the air circulated for ventilation.

5.5 Axial Consolidation Around a Borehole

Brine seepage occurs into drillholes drilled vertically downward from WIPP excavations. This calculation was performed to estimate inflow into 15 m-deep downholes drilled from Room G. The vertical drillhole has a radius of 8.9 cm and intersects the clay B layer about 10 m below the floor of the room. Clay B is about 1 cm thick (Deal and others, 1991b, Section 2.7.3.2). Stress redistribution around Room G will result in compaction of clay B for a distance of about 20 m from the borehole. Brine flow is radially to the borehole along the thin clay seam. As a result, complete compaction will take a fairly long time, over 1,000 years, and would ultimately yield about 340 L of brine. Over a period of 60 to 100 years, approximately 100 to 150 L of brine will seep into the borehole (Appendix F, Fig. F-4-2). After about 10 years, inflow rate is calculated to be about .006 L/day, an order of magnitude lower than the observed inflow below Room G (Table 5-1). The only other

**Table 5-1
Seepage Rate in Drillholes Penetrating Clay B**

Drillhole	Location	Seepage Rate (L/day)
DH36	Room G	0.1
DH38	Room G	0.03
DH40	Room G	0.008
DH42	Room G	0.01
DH42A	Room G	0.02
OH46	S390/W320	0.005

drillhole that penetrates the same stratigraphy and is probably not contaminated with construction brines is OH46, which is drilled from the underground core storage area. Consolidation response should be about the same for OH46 as for the holes in Room G.

All of the drillholes listed in Table 5-1 also intersect clay E and clay D, which are potential sources for additional brine. Clay D is thin and discontinuous and was not considered in the above calculation. The intersection with clay E can be observed from the drillhole collars and is not providing brine to the downholes in Room G.

5.6 Summary

These order-of-magnitude seepage calculations compare well with the observed seepage into Room Q. Calculated seepage rate after 1,600 days is on the order of 0.3 L/day, where the actual observed rate is 0.17 L/day. In this case the model is for flow towards the room along a thin clay seam. Extending this model to a waste storage room predicts that the total seepage into the room will be on the order of 9,000 liters, far short of the 220,000 L necessary to react anoxically with all the susceptible metal placed in the room (Deal and others, 1991b, Section 4.6). Furthermore, seepage into the room will cease after about 100 years.

The case for seepage into a downhole drilled into the strata below an excavation behaves differently, as flow is radially toward the drillhole. In this case, some seepage continues for a long time, perhaps a thousand years or more. It is clear that seepage into drillholes is strikingly different from seepage into a repository excavation. Deal and others (1994, Section 2.7.2) pointed out that seepage into drillholes probably should not be used to predict long-term seepage into a WIPP waste storage room. This calculation provides additional support for this caution.

6.0 Summary and Conclusions

During eleven years of observations (1982 to 1993) the amount of brine seeping into the WIPP excavations is local, limited, and finite. Even a small amount of brine may produce hydrogen gas by anoxic corrosion of the metal in the CH-TRU waste drums and waste inventory. However, the amount of brine that will be available will be only a small percentage of that necessary to corrode all of the metal. The data through 1990 are discussed in detail by Deal and others (1991b). It was concluded that it will take on the order of 220,000 L of brine to corrode all the susceptible metal (iron and aluminum) and that there is probably less than 10 percent available (20,000 L), unless it can be proven that far-field flow does occur at the WIPP. Far-field flow is theoretically unlikely or impossible (Deal and Roggenthen, 1991), and evidence so far confirms that significant seepage of brine ceases about three years after the excavation of an opening, although small seeps can continue for a longer period of time (Deal and others, 1993, Section 5; Deal and Bills, 1994). Calculations presented in Chapter 5 of this report indicate that less than 9,000 L will be available from clay consolidation.

Data gathered in 1992 and 1993 additionally support those conclusions. Continued observations of downholes and Salt Shaft and Waste Shaft sumps where fractured MB 139 can be observed confirm that the exposed surfaces are still dry and show very little evidence of moisture. Inspection of the AIS showed that there was little evidence of moisture or past seepage. Salt encrustations are more common below a depth of 1,500 ft, are clearly stratigraphically controlled, and are associated with clay interbeds and argillaceous halite. Anhydrite exposures are typically dry and free of salt encrustations, indicating that no significant amount of brine flows through them to the shaft.

Both the shaft sumps and the AIS are, in effect, long-term far-field flow experiments. There is no evidence confirming that enough flow exists to supply the needed volume of brine for complete anoxic corrosion of the susceptible metal waste and waste containers that will be emplaced at the WIPP.

Hydrologic testing was performed during this reporting period at two additional areas in order to obtain data on the hydrologic properties of the fractured part of the DRZ that has formed beneath the WIPP excavations. The test results confirmed that the width of an excavation

influences the development of integrated fractures and showed that, in the tested areas in the EO drift and near the AIS, integrated fracture systems only exist beneath intersections. This supports the concept of limited, bounded, fractured fluid reservoirs. Additional evidence that extensive, large-scale hydrologically interconnected fracture system apparently do not exist under much of the WIPP excavation is supplied by the fact that brine stands at different levels in closely spaced drillholes in the floor and that brine is not seeping out of fractures observed in the Salt Shaft and Waste Shaft sumps.

Long-term observations of the salt encrustations (Deal and others, 1993, Section 2.2) confirm and semiquantify that the brine weeps cease about three years (1,000 days) after excavation. Calculations estimate total seepage into a full-sized waste storage room from wall weeps between 43 and 604 L, with an average of less than 300 L (Deal and others, 1993; Table 2-4 and Figure 2-14), much less than 1 percent of the 220,000 L of brine needed to corrode all the susceptible metal in the CH-TRU waste and waste storage drums.

Previous efforts to calculate the amount of moisture that might be released to the repository by clay consolidation (Deal and others, 1993, Section 4) to a full-sized waste storage room was on the order of 400 L of brine. In order to provide a somewhat more rigorous estimate, numerical calculations were performed for this report in order to provide order-of-magnitude estimates of brine seepage that might result from clay compaction. The calculations compare well with the observed seepage into Room Q. Calculated seepage rate after 1,600 days is on the order of 0.3 L/day, where the actual observed rate is 0.17 L/day. In this case the model is for flow towards the room along a thin clay seam. Extending this model to a waste storage room predicts that the total seepage into the room will be on the order of 9,000 L, much of which will evaporate during operations. Furthermore, seepage into the room will cease after about 100 years.

The case for seepage into a downhole drilled into the strata below a WIPP excavation behaves differently, as flow is radially toward the drillhole. In this case, some seepage continues for a long time, perhaps a thousand years or more. It is clear that seepage into drillholes is strikingly different from seepage into a repository excavation. Deal and others (1994, Section 2.7.2) pointed out that seepage into drillholes probably should not be used to predict long term seepage into a WIPP waste storage room. This calculation provides additional support for this caution.

Although there is no observed evidence from the WIPP excavations that brine will seep into the workings from the underlying anhydrite MB 139 (Deal and Bills, 1994), Deal and others (1994) calculated that even if far-field flow occurred in the anhydrite, only about 6,000 L could flow into a WIPP storage room over a 200-year period of time. They point out that due to evaporation during the period of time the excavations are open for waste storage, and because creep closure will repressurize the room even in the absence of gas generation, a more realistic figure may be on the order of 1,700 L.

All of these estimates and calculations are far short of the 220,000 L required to corrode all of the metal and cause maximum gas generation by anoxic corrosion.

THIS PAGE INTENTIONALLY LEFT BLANK

7.0 References

Abitz, R. J., J. Myers, P. E. Drez, and D. E. Deal, 1990, "Geochemistry of Salado Formation Brines Recovered from the Waste Isolation Pilot Plant (WIPP) Repository," *Proceedings of Waste Management '90, Waste Processing, Transportation, Storage and Disposal*, Technical Programs and Public Education, R. G. Post, ed., Tucson, Arizona, Vol. 2, pp. 881-891.

American Society for Testing and Materials (ASTM), 1980, "Recommended Practice for Dealing with Outlying Observations," *Procedure E178-80*, American Society for Testing and Materials, Philadelphia, Pennsylvania.

ASTM, see American Society for Testing and Materials.

Bechtel National, Inc. (Bechtel), 1986, "Waste Isolation Pilot Plant Design Validation Final Report," *DOE-WIPP 86-010*, prepared for the U.S. Department of Energy by Bechtel National, Inc., San Francisco, California.

Bechtel National, Inc. (Bechtel), 1983, "Waste Isolation Pilot Plant Preliminary Design Validation Report," prepared for the U.S. Department of Energy by Bechtel National, Inc., San Francisco, California.

Black, S. R., R. S. Newton, and D. K. Shukla, eds., 1983, "Results of Site Validation Experiments, Waste Isolation Pilot Plant," *DOE-TME-3177*, TSC-D'Appolonia Consulting Engineers, Albuquerque, New Mexico.

Crawley, M. E., T. W. Cooper, R. G. Richardson, 1992, "Hydrologic Testing of the Fractured Part of the Disturbed Rock Zone Beneath the WIPP Excavations," file report prepared for the U.S. Department of Energy by IT Corporation and Westinghouse Electric Corporation, Carlsbad, New Mexico.

Deal, D. E., and J. B. Case, 1987, "Brine Sampling and Evaluation Program, Phase I Report," *DOE-WIPP 87-008*, prepared for the U.S. Department of Energy by IT Corporation and Westinghouse Electric Corporation, Carlsbad, New Mexico, 163 pp.

Deal, D. E., and R. A. Bills, 1994, "Conclusions After Eleven Years of Studying Brine at the Waste Isolation Pilot Plant," *Waste Management '94, Tucson, Arizona, March 2, 1994*, IT Corporation, Albuquerque, New Mexico, and U.S. Department of Energy, Carlsbad, New Mexico.

Deal, D. E., and R. M. Roggenthen, 1991, "Evolution of Hydrologic Systems and Brine Geochemistry in a Deforming Salt Medium: Data from WIPP Brine Seeps," *Waste Management '91, Waste Processing, Transportation, Storage and Disposal*, Technical Programs and Public Education, R. G. Post, ed., Vol. 2, pp. 507-516.

Deal, D. E., R. H. Holt, J. M. Melvin, and S. M. Djordevic, 1994, "Calculation of Brine Seepage from Anhydrite Marker Bed 139 into a Waste Storage Room at the Waste Isolation Pilot Plant," *DOE-WIPP 94-007*, Westinghouse Electric Corporation, Carlsbad, New Mexico.

Deal, D. E., R. J. Abitz, D. S. Belski, J. B. Case, M. E. Crawley, R. M. Deshler, P. E. Drez, C. A. Givens, R. B. King, B. A. Lauctes, J. Myers, S. Niou, J. M. Pietz, W. M. Roggenthen, J. R. Tyburski, and M. G. Wallace, 1989, "Brine Sampling and Evaluation Program Report, 1988," *DOE-WIPP 89-015*, prepared for the U.S. Department of Energy by IT Corporation and Westinghouse Electric Corporation, Carlsbad, New Mexico.

Deal, D. E., R. J. Abitz, D. S. Belski, J. B. Clark, M. E. Crawley, and M. L. Martin, 1991a, "Brine Sampling and Evaluation Program Report, 1989," *DOE-WIPP 91-009*, prepared for U.S. Department of Energy by IT Corporation and Westinghouse Electric Corporation, Carlsbad, New Mexico.

Deal, D. E., R. J. Abitz, J. Myers, D. S. Belski, M. L. Martin, D. J. Milligan, R. W. Sobocinski, and P. P. James Lipponer, 1993, "Brine Sampling and Evaluation Program Report 1991," *DOE-WIPP 93-026*, prepared for U.S. Department of Energy by IT Corporation and Westinghouse Electric Corporation, Carlsbad, New Mexico.

Deal, D. E., R. J. Abitz, J. Myers, J. B. Case, D. S. Belski, M. L. Martin, W. M. Roggenthen, 1991b, "Brine Sampling and Evaluation Program Report, 1990," *DOE-WIPP 91-036*, prepared for U.S. Department of Energy by IT Corporation and Westinghouse Electric Corporation, Carlsbad, New Mexico.

EPA, see U.S. Environmental Protection Agency.

Howarth, S., K. Larson, T. Christian-Frear, R. Beauheim, D. Borns, D. Deal, A. L. Jensen, K. Pickens, R. Roberts, M. Tierney, P. Vaughn, and S. Webb, 1994, "Salado Formation Fluid Flow and Transport Containment Group—White Paper for Systems Prioritization and Technical Baseline, Rev. 1," prepared by Sandia National Laboratories/New Mexico for the U.S. Department of Energy, Carlsbad, New Mexico.

Kennedy and Neville, 1986, (ref) (§ 3.5)

Krumhansl, J. L., and H. W. Stockman, 1987, Memorandum to M. A. Molecke, Sandia National Laboratories, New Mexico, "Test Progress Report—Room J."

Krumhansl, J. L., K. M. Kimball, and C. L. Stein, 1991, "Intergranular Fluid Compositions from the Waste Isolation Pilot Plant (WIPP), Southeastern New Mexico," *SAND90-0584*, Sandia National Laboratories, New Mexico.

Lohman, S. W., 1972, "Ground-Water Hydraulics," U.S. Geological Survey Professional Paper 708, U.S. Government Printing Office, 70 pp.

- Morse, J. G., and B. W. Hassinger, April, 1985, "Brine Testing Program Plan: Waste Isolation Pilot Plant (WIPP) Project, Carlsbad, New Mexico, Revision 2," *WD:85:01214*, internal document transmitted as a letter from W. R. Cooper to R. H. Neil, Waste Isolation Pilot Plant, AEH 85:086.
- Powers, D. W., S. J. Lambert, S. E. Shaffer, L. R. Hill, and W. D. Weart, eds., 1978, "Geological Characterization Report, Waste Isolation Pilot Plant (WIPP) Site, Southeastern New Mexico," *SAND78-1596*, Vols. I and II, Sandia National Laboratories, Albuquerque, New Mexico.
- SNL/NM, see Sandia National Laboratories/New Mexico.
- Stein, C. L., and J. L. Krumhansl, 1988, "A Model for the Evolution of Brines in Salt from the Lower Salado Formation, Southeastern New Mexico," *Geochimica et Cosmochimica Acta*, Vol. 52, pp. 1037-1046.
- Stein, C. L., and J. L. Krumhansl, 1986, "Chemistry of Brines in Salt From the Waste Isolation Pilot Plant (WIPP), Southeastern New Mexico: A Preliminary Investigation," *SAND85-0897*, Sandia National Laboratories, New Mexico.
- U.S. Environmental Protection Agency (EPA), 1989, (supply elements) ¶3.6 530-SW-89-026.
- DOE/WIPP 92-007, 1992, Waste Isolation Pilot Plant Site Environmental Report for Calendar Year 1991, prepared for the U. S. Department of Energy by Westinghouse Electric Corporation and IT Corporation, Carlsbad, New Mexico.

THIS PAGE INTENTIONALLY LEFT BLANK

APPENDIX A BRINE ACCUMULATION

**PART I—LIST OF UNDERGROUND LOCATIONS WHERE BRINE
OCCURRENCES WERE OBSERVED AND MONITORED**

PART II—BRINE ACCUMULATION DATA TABLES

THIS PAGE INTENTIONALLY LEFT BLANK

APPENDIX A BRINE ACCUMULATION

PART I—LIST OF UNDERGROUND LOCATIONS WHERE BRINE OCCURRENCES WERE OBSERVED AND MONITORED

THIS PAGE INTENTIONALLY LEFT BLANK

Table A-1
List of Underground Locations Where Brine Occurrences
Were Observed and Monitored Through December, 1993
As Part of the Brine Sampling and Evaluation Program at WIPP

Hole Number	Room or Location	Survey Accuracy S=Surveyed A=Approximate	North-South Coordinates*	East-West Coordinates*	Elevation m	Dia. cm	Length m	Direction U=Up D=Down H=Horiz.	Angle in Degrees	References**	Remarks
A1X01	A1	S	N1147.02	E1254.40	400.28	10	15.2	D	90	B, D, E	Monitored as part of the BSEP from 3/85 to 2/91.
A1X02	A1	S	N1146.88	E1254.24	405.78	10	18	U	90	B, D, E	Monitored as part of the BSEP since it was drilled in 3/85, to 8/93 when collecting device malfunctioned and became erratic.
A2X01	A2	S	N1393.72	E1338.88	399.65	10	15.3	D	90	B, D, E	Monitored as part of the BSEP from 2/85 to 10/90.
A2X02	A2	S	N1393.65	E1338.89	405.03	10	16.1	U	90	B, D, E	Monitored as part of the BSEP from 2/85 to 9/89.
A3X01	A3	S	N1137.94	E1406.84	399.22	10	15.4	D	90	B, D, E	Monitored as part of the BSEP from when it was drilled in 1/85 to 6/93. Drillers did not report any moisture while drilling. Hole started producing brine a few weeks later.
A3X02	A3	S	N1138.00	E1406.89	404.75	10	15.5	U	90	B, D, E	Monitored from 1/85 to 9/89. Drillers did not encounter moisture while drilling. Hole started producing brine a few weeks later.
BTPA1	S1620/W170	A	S1638	W162	384	7.6	1.6	D	90	B	Open from 0 to 1.6 m. Drilled for the BSEP study 7/86 and monitored until 12/02/88.
BTPA2	S1620/W170	A	S1638	W166	384	7.6	2.8	D	90	B	Cased from 0 to 1.6 m. Open from 1.6 to 2.8 m. Drilled for the BSEP study 7/86 and monitored until 12/02/88.
BTPA3	S1620/W170	A	S1638	W170	384	7.6	4.1	D	90	B	Cased from 0 to 3.1 m. Open from 3.1 to 4.1 m. Drilled for the BSEP study 7/86 and monitored until 12/02/88.
BTPA4	S1620/W170	A	S1638	W166	388	7.6	1.4	U	90	B	Open from 0 to 1.4 m. Drilled for the BSEP study 7/86 and monitored until 9/27/88. Dry.
BTPA5	S1620/W170	A	S1638	W170	388	7.6	1.6	U	90	B	Open from 0 to 1.6 m. Drilled for the BSEP study 7/86 and monitored until 9/27/88. Dry.

*The repository is referenced in feet; therefore, the North-South and East-West coordinates are presented in feet.

**For references, see footnote at end of table.

Table A-1 (Continued)
List of Underground Locations Where Brine Occurrences
Were Observed and Monitored Through December, 1993
As Part of the Brine Sampling and Evaluation Program at WIPP

Hole Number	Room or Location	Survey Accuracy S=Surveyed A=Approximate	North-South Coordinates*	East-West Coordinates*	Elevation m	Dia. cm	Length m	Direction U=Up D=Down H=Horiz.	Angle in Degrees	References**	Remarks
BTPB1	S1620/W170	A	S1636	W162	384	7.6	1.6	D	90	B	Open from 0 to 1.6 m. Drilled for the BSEP study 7/86 and monitored until 9/27/88.
BTPB2	S1620/W170	A	S1636	W166	384	7.6	2.9	D	90	B	Cased 0 to 1.8 m. Open from 1.8 to 2.9 m. Drilled for the BSEP study 7/86 and monitored until 9/27/88.
BTPB3	S1620/W170	A	S1636	W170	384	7.6	4.1	D	90	B	Cased 0 to 3.1 m. Open from 3.0 to 4.1 m. Drilled for the BSEP study 7/86 and monitored until 9/27/88.
BTPB4	S1620/W170	A	S1636	W166	388	7.6	3.0	U	90	B	Cased 0 to 2.1 m. Open from 2.1 to 3.0 m. Drilled for the BSEP study 7/86 and monitored until 9/27/88.
BTPB5	S1620/W170	A	S1636	W170	388	7.6	3.1	U	90	B	Cased 0 to 1.9 m. Open from 1.9 to 3.1 m. Drilled for the BSEP study 7/86 and monitored until 9/27/88.
BTPC1	S1620/W170	A	S1634	W162	384	7.6	1.5	D	90	B	Open from 0 to 1.5 m. Drilled for the BSEP study 7/86 and monitored until 9/27/88.
BTPC2	S1620/W170	A	S1634	W166	384	7.6	3.0	D	90	B	Cased from 0 to 1.7 m. Open from 1.8 to 3.0 m. Drilled for the BSEP study 8/86 and monitored until 9/27/88.
BTPC3	S1620/W170	A	S1634	W170	384	7.6	4.4	D	90	B	Cased from 0 to 3.0 m. Open from 3.0 to 4.4 m. Drilled for the BSEP study 8/86 and monitored until 9/27/88.
BTPC4	S1620/W170	A	S1634	W166	388	7.6	5.4	U	90	B	Cased from 0 to 4.2 m. Open from 4.2 to 5.4 m. Drilled for the BSEP study 7/86 and monitored until 9/27/88.
BTPC5	S1620/W170	A	S1634	W170	388	7.6	5.5	U	90	B	Cased from 0 to 4.3 m. Open from 4.3 to 5.5 m. Drilled for the BSEP study 7/86 and monitored until 9/27/88. Dry.

*The repository is referenced in feet; therefore, the North-South and East-West coordinates are presented in feet.

**For references, see footnote at end of table.

Table A-1 (Continued)
List of Underground Locations Where Brine Occurrences
Were Observed and Monitored Through December, 1993
As Part of the Brine Sampling and Evaluation Program at WIPP

Hole Number	Room or Location	Survey Accuracy S=Surveyed A=Approximate	North-South Coordinates*	East-West Coordinates*	Elevation m	Dia. cm	Length m	Direction U=Up D=Down H=Horiz.	Angle in Degrees	References**	Remarks
BTR1	S1950/E100	A	S1942	E98	387	8.3	0.3	H	5	B	Hole slightly declined below horizontal. Collar above upper clay seam, about 0.3 m below back. Drilled 6/86 and monitored until 9/27/88. Dry.
BTR2	S1950/E100	A	S1942	E100	387	8.3	1.0	H	5	B	Hole slightly declined below horizontal. Collar above upper clay seam, about 0.3 m below back. Drilled 6/86 and monitored until 12/02/88.
BTR3	S1950/E100	A	S1942	E101	387	8.3	1.0	H	5	B	Hole slightly declined below horizontal. Collar above upper clay seam, about 0.3 m below back. Drilled 6/86 and monitored until 12/02/88.
BTR4	S1950/E100	A	S1942	E98	386	8.3	0.3	H	5	B	Hole slightly declined below horizontal. Collar in halite about 1.1 m below back. Drilled 6/86 and monitored until 12/02/88.
BTR5	S1950/E100	A	S1942	E100	386	8.3	0.9	H	5	B	Hole slightly declined below horizontal. Collar in halite about 1.1 m below back. Drilled 6/86 and monitored until 12/02/88.
BTR6	S1950/E100	A	S1942	E101	386	8.3	0.9	H	5	B	Hole slightly declined below horizontal. Collar in halite about 1.1 m below back. Drilled 6/86 and monitored until 12/02/88.
BTR7	S1950/E100	A	S1942	E98	386	8.3	0.3	H	5	B	Hole slightly declined below horizontal. Collar just above orange band. Drilled 6/86 and monitored until 12/02/88. Dry.
BTR8	S1950/E100	A	S1942	E100	386	8.3	0.9	H	5	B	Hole slightly declined below horizontal. Collar just above orange band. Drilled 6/86 and monitored until 12/02/88.
BTR9	S1950/E100	A	S1942	E101	386	8.3	0.9	H	5	B	Hole slightly declined below horizontal. Collar just above orange band. Drilled 6/86 and monitored until 12/02/88.

*The repository is referenced in feet; therefore, the North-South and East-West coordinates are presented in feet.

**For references, see footnote at end of table.

Table A-1 (Continued)
List of Underground Locations Where Brine Occurrences
Were Observed and Monitored Through December, 1993
As Part of the Brine Sampling and Evaluation Program at WIPP

Hole Number	Room or Location	Survey Accuracy S=Surveyed A=Approximate	North-South Coordinates*	East-West Coordinates*	Elevation m	Dia. cm	Length m	Direction U=Up D=Down H=Horiz.	Angle in Degrees	References**	Remarks
BTR10	S1950/E100	A	S1942	E98	385	8.3	0.4	H	5	B	Hole slightly declined below horizontal. Collar about 0.8 m above floor. Drilled 6/86 and monitored until 12/02/88. Dry.
BTR11	S1950/E100	A	S1942	E100	385	8.3	0.9	H	5	B	Hole slightly declined below horizontal. Collar about 0.8 m above floor. Drilled 6/86 and monitored until 12/02/88.
BTR12	S1950/E100	A	S1942	E101	385	8.3	0.9	H	5	B	Hole slightly declined below horizontal. Collar about 0.8 m above floor. Drilled 6/86 and monitored until 12/02/88.
BX01	B	S	N1384.68	E982.33	401.56	10	15.3	D	90	B, E	Monitored as part of the BSEP from when it was drilled in 1/85 to 4/93. Core moist from 10.6 to 11.1 m in coarsely crystalline clear halite. MB139 at 7.1 to 7.9 m.
BX02	B	S	N1384.44	E982.87	407.05	10	15.0	U	90	B, E	Monitored as part of the BSEP from 1/85 to 12/89.
DH15	N1140/E1689	A	N1140	E1688.5	402	7.6	15.5	U	90	B	Moisture noticed at collar in 4/86. Collecting device installed 5/86 and monitored as part of the BSEP since then. At present no brine is collected because of insufficient inflow.
DH35	G	A	N1102	W1882	395	8.9	15.8	U	90	A3, B	Monitored as part of the BSEP since 2/85. At present no brine is collected because of insufficient inflow.
DH36	G	A	N1102	W1882	392	8.9	15.7	D	90	A3, B	Monitored as part of the BSEP since 1/85.
DH37	G	A	N1101	W2182	396	8.9	15.7	U	90	A3, B	Monitored as part of the BSEP since 1/85. At the present no brine is collected because of insufficient inflow.
DH38	G	A	N1101	W2182	392	8.9	14.5	D	90	A3, B	Monitored as part of the BSEP since 1/85.

*The repository is referenced in feet; therefore, the North-South and East-West coordinates are presented in feet.

**For references, see footnote at end of table.

Table A-1 (Continued)
List of Underground Locations Where Brine Occurrences
Were Observed and Monitored Through December, 1993
As Part of the Brine Sampling and Evaluation Program at WIPP

Hole Number	Room or Location	Survey Accuracy S=Surveyed A=Approximate	North-South Coordinates*	East-West Coordinates*	Elevation m	Dia. cm	Length m	Direction U=Up D=Down H=Horiz.	Angle in Degrees	References**	Remarks
DH39	G	A	N1101	W2482	395	8.9	14.5	U	90	A3, B	Monitored as part of the BTP since 2/85. At the present no brine is collected because of insufficient inflow.
DH40	G	A	N1101	W2482	392	8.9	15.5	D	90	A3, B	Monitored as part of the BSEP since 1/85.
DH41	G	A	N1101	W2782	395	8.9	15.2	U	90	A3, B	Monitored as part of the BSEP since 2/85. At the present no brine is collected because of insufficient inflow.
DH42	G	A	N1101	W2782	392	8.9	15.6	D	90	A3, B	Monitored as part of the BSEP since 2/85.
DH42A	G	A	N1101	W2789	392	8.9	12.6	D	90	A3, B	Monitored as part of the BSEP since 2/85.
DH215	S1960/E153	A	S1960	E153	388	7.6	15.8	U	90	A1, B	Gas releases had been observed in this hole. Monitored as part of the BSEP from 1/85 to 11/90. At the present no brine is collected due to insufficient inflow.
DH216	S1960/E153	A	S1960	E153	385	7.6	16.5	D	90	A1, B	Gas releases had been observed in this hole. Monitored as part of the BSEP from 1/85 to 6/85 when collar was destroyed and hole plugged by mining.
DH317	S1600/W30	A	S1600	W33	388	7.6	15.3	U	90	A2, B	Stalactite growth monitored as part of the BSEP from 5/85 to 2/86.
DH317A	S1600/W30	A	S1600	W28	388	7.6	1.5	U	90	A2, B	Stalactite growth monitored as part of the BSEP from 5/85 to 2/86.
DH317B	S1600/W30	A	S1597	W27	388	8.9	15.5	U	90	A2, B	Gas pocket at 14.0 m. Brine seeped from hole after drill rods were broken at end of run at depth of 5 m. Probable source was anhydrite "a". Stalactite growth monitored as part of the BSEP from 5/85 to 2/86.

*The repository is referenced in feet; therefore, the North-South and East-West coordinates are presented in feet.

**For references, see footnote at end of table.

Table A-1 (Continued)
List of Underground Locations Where Brine Occurrences
Were Observed and Monitored Through December, 1993
As Part of the Brine Sampling and Evaluation Program at WIPP

Hole Number	Room or Location	Survey Accuracy S=Surveyed A=Approximate	North-South Coordinates*	East-West Coordinates*	Elevation m	Dia. cm	Length m	Direction U=Up D=Down H=Horiz.	Angle in Degrees	References**	Remarks
DHP401	S1950/E1330	A	S1950	E1330	387	10	15.1	U	90	B	Drilled 1/87, observed as part of the BSEP since 3/87. At the present no brine is collected due to insufficient inflow.
DHP402A	S1950/E1330	A	S1950	E1330	383	10	15.2	D	90	B	Drilled 12/86, observed as part of the BSEP since 12/86. Hole offset at 13.7 m. There may be a rock bolt or piece of steel in hole.
EES12B	N1430/E0140	A	N1430	E140	398	4.7	3	D	90	K	Drilled 6/86 as part of the Excavation Effects Study. Observed as part of the BSEP from date of drilling until 12/86. Rapid brine and gas inflow through open fractures.
EES21B	S0700/E0066	A	S700	E66	381	4.7	2.7	D	90	K	Drilled 7/86 as part of the Excavation Effects Study. Observed as part of the BSEP since drilling until 12/86. Rapid brine and gas inflow through fractures.
GSEEP	G	A	N1095	W1837	391					B	Damp area on the floor of Room G, near south rib, approximately 13.7 m east of DH35. Seep noticed 8/85. Damp area larger in 11/85. Monitored as part of the BSEP since 11/85. 40 cm diameter collecting sump drilled 9/87.
IG201	2	S	N1275.54	W379.51	394.71	7.3	16.4	D	90	A3, B, H, J	Monitored as part of the BSEP from 11/84 to 9/87 when shear closure pinched hole shut so that sampler would not go to bottom.
IG202	1	S	N1264.79	W246.11	395.17	7.3	14.7	D	90	A3, B, H, J	Monitored as part of the BSEP from 11/84 to 7/87 when shear closure pinched hole shut so that sampler would not go to bottom. Last BSEP brine data collected in 3/87.
JV8	J	S	N1067	W374	393	91	2.5	D	90	D, F, G	Drilled 8/08/85; drillers reported water at 2.4 m. Not monitored after initial observation.

*The repository is referenced in feet; therefore, the North-South and East-West coordinates are presented in feet.

**For references, see footnote at end of table.

Table A-1 (Continued)
List of Underground Locations Where Brine Occurrences
Were Observed and Monitored Through December, 1993
As Part of the Brine Sampling and Evaluation Program at WIPP

Hole Number	Room or Location	Survey Accuracy S=Surveyed A=Approximate	North-South Coordinates*	East-West Coordinates*	Elevation m	Dia. cm	Length m	Direction U=Up D=Down H=Horiz.	Angle in Degrees	References**	Remarks
JV9	J	S	N1067	W378	393.3	91	2.5	D	90	D, G	Brine in bottom of pilot hole on 8/20/85. Not monitored after initial observation.
L1S25	L1	A	N1524	W218	400	10	3.6	D	90	B, H	Monitored as part of the BSEP from 8/85 to 6/89.
L1S26	L1	A	N1524	W220	400	10	3.6	D	90	B, H	Monitored as part of the BSEP from 8/85 to 6/89.
L1S27	L1	A	N1524	W222	400	10	3.6	D	90	B, H	Monitored as part of the BSEP from 8/85 to 6/89.
L1S28	L1	A	N1524	W224	400	10	3.7	D	90	B, H	Monitored as part of the BSEP from 8/85 to 6/89.
L1S29	L1	A	N1524	W226	400	10	3.7	D	90	B, H	Monitored as part of the BSEP from 8/85 to 6/89.
L1S30	L1	A	N1524	W228	400	10	3.7	D	90	B, H	Monitored as part of the BSEP from 8/85 to 6/89.
L1S31	L1	A	N1524	W235	400	10	3.6	D	90	B, H	Monitored as part of the BSEP from 8/85 to 6/89.
L1S32	L1	A	N1524	W237	400	10	3.6	D	90	B, H	Monitored as part of the BSEP from 8/85 to 6/89.
L1S33	L1	A	N1524	W239	400	10	3.6	D	90	B, H	Monitored as part of the BSEP from 8/85 to 6/89.
L1S34	L1	A	N1524	W241	400	10	3.7	D	90	B, H	Monitored as part of the BSEP from 8/85 to 6/89.
L1S35	L1	A	N1524	W243	400	10	3.8	D	90	B, H	Monitored as part of the BSEP from 8/85 to 6/89.
L1S36	L1	A	N1524	W245	400	10	3.7	D	90	B, H	Monitored as part of the BSEP from 8/85 to 6/89.
L1X00	L1	A	N1538.5	W225	400	10	3.8	D	90	B, H	Drillers found water in hole at 3 m, 5/13/84. Monitored as part of the BSEP from 10/84 to 4/89.
L2C03	L2	A	N1510	W365	400	41	3.7	D	90	B, H	Drilled 4/85 overcoring and destroying L2C25. Brine and gas enters hole quickly through open fractures. Monitored intermittently as part of the BSEP from 12/85 through 12/86.

*The repository is referenced in feet; therefore, the North-South and East-West coordinates are presented in feet.

**For references, see footnote at end of table.

Table A-1 (Continued)
List of Underground Locations Where Brine Occurrences
Were Observed and Monitored Through December, 1993
As Part of the Brine Sampling and Evaluation Program at WIPP

Hole Number	Room or Location	Survey Accuracy S=Surveyed A=Approximate	North-South Coordinates*	East-West Coordinates*	Elevation m	Dia. cm	Length m	Direction U=Up D=Down H=Horiz.	Angle in Degrees	References**	Remarks
L2C25	L1	A	N1510	W365	400	12.7	3.5	D	90	B, H	L2C25 is a 12.7 cm overcore of a previously grouted SNL/NM test hole. The overcore was drilled 3/85 and air and brine was blown through fractures into hole L2C29, 1.2 m to the north. In 4/85, a 40 cm overcore was made destroying this hole. The larger hole is designated L2C03.
MIIT2	J	S	N1088.03	W377.02	393.44	8.3	0.9	D	90	B, D, G	Brine since drilled; monitored from 10/84 to 4/85.
MIIT4	J	S	N1086.05	W377.13	393.44	8.3	1.0	D	90	B, D, G	Brine since drilled; monitored from 10/84 to 4/85.
MIIT6	J	S	N1084.16	W377.15	393.36	8.3	1.0	D	90	B, D, G	Brine since drilled; monitored from 10/84 to 4/85.
MIIT8	J	S	N1082.08	W377.24	393.34	8.3	1.0	D	90	B, D, G	Brine since drilled; monitored from 10/84 to 4/85.
MIIT10	J	S	N1079.98	W377.23	393.31	8.3	1.0	D	90	B, D, G	Brine since drilled; monitored from 10/84 to 4/85.
MIIT12	J	S	N1078.11	W377.21	393.25	8.3	1.0	D	90	B, D, G	Brine since drilled; monitored from 10/84 to 4/85.
MIIT14	J	S	N1076.18	W377.30	393.14	7.6	1.0	D	90	B, D, G	Brine since drilled; monitored from 10/84 to 4/85.
MIIT16	J	S	N1074.17	W377.18	392.95	7.6	1.0	D	90	B, D, G	Brine since drilled; monitored from 10/84 to 4/85.
MIIT17	J	S	N1072.03	W379.10	393.29	7.6	1.0	D	90	B, D, G	Brine since drilled; monitored from 10/84 to 4/85. SNL/NM filled hole with Brine A 4/30/85 and plugged with rubber cork.
MIIT18	J	S	N1071.91	W377.18	393.27	7.6	1.0	D	90	B, D, G	Brine since drilled; monitored from 10/84 through 4/85. SNL/NM experiment filled hole with Brine A 4/20/85 and plugged hole with rubber cork.
MIIT20	J	S	N1069.84	W377.22	393.30	7.6	1.8	D	90	B, D, G	Brine noted 10/84; monitored from 10/84 through 4/85.
MIIT22	J	S	N1067.93	W377.23	393.30	7.6	1.8	D	90	B, D, G	Brine noted 10/84; monitored from 10/84 through 4/85.

*The repository is referenced in feet; therefore, the North-South and East-West coordinates are presented in feet.

**For references, see footnote at end of table.

Table A-1 (Continued)
List of Underground Locations Where Brine Occurrences
Were Observed and Monitored Through December, 1993
As Part of the Brine Sampling and Evaluation Program at WIPP

Hole Number	Room or Location	Survey Accuracy S=Surveyed A=Approximate	North-South Coordinates*	East-West Coordinates*	Elevation m	Dia. cm	Length m	Direction U=Up D=Down H=Horiz.	Angle in Degrees	References**	Remarks
MIIT24	J	S	N1065.79	W377.21	393.42	7.6	1.8	D	90	B, D, G	Brine noted 10/84; monitored 10/84 through 4/85, SNL/NM experiment added Brine A to hole 4/30/85 and plugged with rubber cork.
MIITP	J	A	N1067	W378	393	3.8	2.7	D	90	B, F	Brine since drilled; pilot hole for 0.9-m-diameter hole that was never completed. Monitored from 4/02/85 through 4/23/85.
NG252	2	S	N1275.86	W381.05	394.68	3.8	2.3	D	90	A3, B, H, J	Monitored as part of the BSEP from 11/84 to 4/89. This hole constantly produced gas. First time noticed was before 10/84. Room closed 6/89.
OH20	S1600/W170	S	S1610.36	W177.16	386.22	8.9	47.2	H	0-3	L	Collared about 0.3 m above the orange band, bottoms in Map Unit 0 below the orange band. Monitored as part of the BSEP since it was drilled 3/89.
OH21	S1600/W170	S	S1605.36	W177.16	385.50	8.9	16.2	H	0-3	L	Collared about 0.3 m below the orange band. Monitored for the BSEP since it was drilled 12/88.
OH22	S1600/W170	S	S1615.36	W177.16	386.65	8.9	15.1	H	0-3	L	Collared about 0.6 m above the orange band. Monitored for the BSEP since it was drilled 12/88.
OH23	S1950/W170	S	S1950.41	W178.86	384.94	8.9	46.0	H	0-3	L	Collared about 0.3 m above the orange band, bottoms in Map Unit 0 below the orange band. Monitored for the BSEP since it was drilled 2/89.
OH24	S1950/W170	S	S1945.41	W178.86	384.11	8.9	15.2	H	0-3	L	Collared about 0.3 m below the orange band. Monitored for the BSEP from 3/89 to 8/90.
OH25	S1950/W170	S	S1955.41	W178.86	385.27	8.9	15.2	H	0-3	L	Collared about 0.6 m above the orange band. Monitored for the BSEP from 3/89 to 8/90.
OH26	S2180/W170	S	S2183.01	W177.14	384.70	8.9	45.7	H	0-3	L	Collared about 0.3 m above the orange band, bottoms in Map Unit 0 below the orange band. Monitored for the BSEP since it was drilled 3/89.

*The repository is referenced in feet; therefore, the North-South and East-West coordinates are presented in feet.

**For references, see footnote at end of table.

AL/L-95/WP/WIP/R3192.TBL

A-I-9

301681.08

BRINE SAMPLING AND EVALUATION PROGRAM REPORT 1992-1993

APPENDIX A-1

Table A-1 (Continued)
List of Underground Locations Where Brine Occurrences
Were Observed and Monitored Through December, 1993
As Part of the Brine Sampling and Evaluation Program at WIPP

Hole Number	Room or Location	Survey Accuracy S=Surveyed A=Approximate	North-South Coordinates*	East-West Coordinates*	Elevation m	Dia. cm	Length m	Direction U=Up D=Down H=Horiz.	Angle in Degrees	References**	Remarks
OH27	S2180/W170	S	S2178.01	W177.14	385	8.9	15.1	H	0-3	L	Collared about 0.6 m above the orange band. Monitored for the BSEP since it was drilled 4/89 to 10/91. Hole dry.
OH27A	S2180/W170	S	S2177.01	W177.14	385	8.9	1.2	H	0-3	L	Short offset hole to OH27. Collared about 0.6 m above the orange band. Monitored for the BSEP since it was drilled 4/89 to 12/89. Hole dry.
OH28	S2180/W170	S	S2188.01	W177.14	383.78	8.9	15.1	H	0-3	L	Collared about 0.3 m below the orange band. Monitored for the BSEP since it was drilled 4/89.
OH35	AIS/S90	S	S100.73	W628.97	383.45	8.9	3.1	D	90	M	Drilled for hydrologic testing of fractures beneath the floor. Not a part of routine BSEP sampling.
OH36	AIS/S90	S	S96.71	W623.11	383.39	8.9	3.1	D	90	M	Drilled for hydrologic testing of fractures beneath the floor. Not a part of routine BSEP sampling.
OH37	AIS/S90	S	S97.66	W609.39	383.35	8.9	3.1	D	90	M	Drilled for hydrologic testing of fractures beneath the floor. Not a part of routine BSEP sampling.
OH38	AIS/S90	S	S97.35	W595.62	383.36	8.9	3.1	D	90	M	Drilled for Marker Bed 139 hydrologic testing. Not a part of routine BSEP sampling.
OH39	AIS/S90	A	S97	W540	383	8.9	3	D	90	M	Drilled for hydrologic testing of fractures beneath the floor. Not a part of routine BSEP sampling.
OH40	AIS/S90	S	S96.91	W485.10	383.02	8.9	3	D	90	M	Drilled for hydrologic testing of fractures beneath the floor. Not a part of routine BSEP sampling.
OH41	AIS/S90	S	S110.52	W622.79	383.44	8.9	3.5	D	90	M	Drilled for hydrologic testing of fractures beneath the floor. Not a part of routine BSEP sampling.
OH42	AIS/S90	S	S43.44	W622.54	383.62	8.9	3.2	D	90	M	Drilled for hydrologic testing of fractures beneath the floor. Not a part of routine BSEP sampling.

*The repository is referenced in feet; therefore, the North-South and East-West coordinates are presented in feet.

**For references, see footnote at end of table.

Table A-1 (Continued)
List of Underground Locations Where Brine Occurrences
Were Observed and Monitored Through December, 1993
As Part of the Brine Sampling and Evaluation Program at WIPP

Hole Number	Room or Location	Survey Accuracy S=Surveyed A=Approximate	North-South Coordinates*	East-West Coordinates*	Elevation m	Dia. cm	Length m	Direction U=Up D=Down H=Horiz.	Angle in Degrees	References**	Remarks
OH43	AIS/S90	S	S124.01	W622.52	383.45	8.9	3.7	D	90	M	Drilled for hydrologic testing of fractures beneath the floor. Not a part of routine BSEP sampling.
OH44	AIS/S90	S	S134.53	W622.31	383.46	8.9	3.4	D	90	M	Drilled for hydrologic testing of fractures beneath the floor. Not a part of routine BSEP sampling.
OH45	Core Library	S	S391.51	W326.35	384.15	8.9	14.9	H	0-3	L	Monitored for the BSEP since it was drilled 6/89.
OH46	Core Library	S	S391.51	W319.01	381.65	8.9	15.3	D	90	L	Monitored for the BSEP since it was drilled 6/89.
OH47	Core Library	S	S391.51	W319.01	385.90	8.9	15.2	U	90	L	Monitored for the BSEP since it was drilled 7/89. Hole dry.
P4X84	SPDV Room 4	A	N1138	W0644	394	91.4	4.8	D	90	B	Large diameter downhole in south end of Room 4 often shown to visitors. MB 139 and fractures beneath the floor are well exposed, both of which are dry. This is good evidence that no far-field flow exists.
PR2	S1600/E140	A	S1600	E140	388	5	6.1	U	90	B, C	Stalactite growth monitored as part of the BSEP from 5/85 to 2/86.
PR3	S1282/E140	A	S2182	E140	385	5	6.1	U	90	B, C	Stalactite growth monitored as part of the BSEP from 5/85 to 2/86.
PR4	S2748/E140	A	S2748	E140	381	5	6.1	U	90	B, C	Stalactite growth monitored as part of the BSEP from 5/85 to 2/86.
WWC1	Room C1	A	N1420	E1572	398.96	91	4.9	H	0	B	Large horizontal hole on south rib of N1420 drift, across from Room C1. Photographically monitored for salt buildup.

*The repository is referenced in feet; therefore, the North-South and East-West coordinates are presented in feet.

**For references, see footnote at end of table.

Table A-1 (Concluded)
List of Underground Locations Where Brine Occurrences
Were Observed and Monitored Through December, 1993
As Part of the Brine Sampling And Evaluation Program at WIPP

Footnote

- A1 TSC-D'Appolonia, 1983 (WIPP-DOE-163)
- A2 Bechtel, 1984 (WIPP-DOE-202)
- A3 Bechtel, 1985 (WIPP-DOE-213)
- B Brine Sampling and Evaluation Program File
- C Records of Special Drill Holes, September 12, 1983: BSEP Files
- D As-Built Survey Calculation Sheets: BSEP Files
- E Field Notes, J. Gallerani, Bechtel: BSEP Files
- F Field Notes, D. Deal, IT Corporation: BSEP Files
- G Room J Brine Survey: BSEP Files
- H Room L1 and L2 Field Notes: BSEP Files
- J Geotechnical Instrumentation List, November 2, 1983: BSEP files
- K Excavation Effects Drilling Program, Data Transmittal August 12, 1986: Excavation Effects Files: WIPP Geotechnical Engineering Files
- L Drilling Record Log: BSEP Files
- N Survey Data Sheet: WIPP Geotechnical Engineering Files

APPENDIX A
BRINE ACCUMULATION

PART II—BRINE ACCUMULATION DATA TABLES

THIS PAGE INTENTIONALLY LEFT BLANK

TABLE A-2
BRINE ACCUMULATION DATA TABLE

Data through December 31, 1993

LOCATION	DATE	TIME	LITERS REMOVED	DAYS SINCE 1/1/85	DAYS USED FOR CALCULATION	LITERS PER DAY	CUMULATIVE LITERS COLLECTED	REMARKS
A1X02	10/10/84	00:00	NA	0.000	0.000	0.000	0.00	Room A1 completed.
A1X02	03/07/85	09:30	NA	65.396	0.000	0.000	0.00	Uphole drilled 2/27/85 to 3/07/85. Hit brine at 12 ft. on 2/27/85.
A1X02	03/12/85	12:00	NA	70.500	0.000	0.000	0.00	Trace brine, deepened hole to clay seam. Moisture on back 1 ft radius.
A1X02	03/20/85	13:00	NA	78.542	0.000	0.000	0.00	Trace brine, drip missing funnel.
A1X02	03/26/85	11:25	NA	84.476	0.000	0.000	0.00	Repositioned funnel, collected one cup of salt crystals with trace of brine.
A1X02	04/02/85	12:15	00.21	91.510	174.510	0.001	0.21	Some drips missing funnel.
A1X02	04/10/85	12:20	00.22	99.514	8.004	0.027	0.43	Collecting container had leak.
A1X02	04/17/85	11:30	00.12	106.479	6.965	0.017	0.55	Some drips missing funnel.
A1X02	04/23/85	10:50	00.12	112.451	5.972	0.020	0.67	Some drips missing funnel.
A1X02	04/30/85	13:16	00.12	119.553	7.102	0.017	0.79	Some drips missing funnel.
A1X02	05/07/85	09:05	00.16	126.378	6.825	0.023	0.95	
A1X02	05/14/85	10:04	00.19	133.419	7.041	0.027	1.14	
A1X02	05/21/85	11:35	00.13	140.483	7.064	0.018	1.27	Some drips missing funnel.
A1X02	05/29/85	10:00	00.21	148.417	7.934	0.026	1.48	
A1X02	06/04/85	10:25	00.17	154.434	6.017	0.028	1.65	
A1X02	06/11/85	09:40	00.05	161.403	6.969	0.007	1.70	
A1X02	06/18/85	09:30	00.08	168.396	6.993	0.011	1.78	Some drips missing funnel, big stalactite formed.
A1X02	06/25/85	09:45	00.16	175.406	7.010	0.023	1.94	
A1X02	07/02/85	11:00	00.10	182.458	7.052	0.014	2.04	
A1X02	07/09/85	09:58	00.15	189.415	6.957	0.022	2.19	
A1X02	07/16/85	10:53	00.24	196.453	7.038	0.034	2.43	
A1X02	07/24/85	09:49	00.24	204.409	7.956	0.030	2.67	
A1X02	07/30/85	09:30	00.15	210.396	5.987	0.025	2.82	
A1X02	08/06/85	09:35	00.14	217.399	7.003	0.020	2.96	
A1X02	08/14/85	09:26	00.05	225.393	7.994	0.006	3.01	
A1X02	08/20/85	10:13	00.09	231.426	6.033	0.015	3.10	
A1X02	08/28/85	09:08	00.06	239.381	7.955	0.008	3.16	
A1X02	09/04/85	09:44	00.07	246.406	7.025	0.010	3.23	
A1X02	09/10/85	09:24	00.12	252.392	5.986	0.020	3.35	
A1X02	09/17/85	09:08	00.13	259.381	6.989	0.019	3.48	Some drips missing funnel.
A1X02	09/24/85	09:07	00.17	266.380	6.999	0.024	3.65	
A1X02	10/01/85	09:21	00.14	273.390	7.010	0.020	3.79	
A1X02	10/08/85	12:19	00.16	280.513	7.123	0.022	3.95	Room A1 heaters turned on 10/02/85.
A1X02	10/15/85	09:41	00.12	287.403	6.890	0.017	4.07	
A1X02	10/23/85	09:43	00.19	295.405	8.002	0.024	4.26	
A1X02	10/29/85	11:02	00.12	301.460	6.055	0.020	4.38	
A1X02	11/05/85	08:46	00.12	308.365	6.905	0.017	4.50	
A1X02	11/13/85	09:16	00.13	316.386	8.021	0.016	4.63	Some drips missing funnel.
A1X02	11/21/85	10:45	00.13	324.448	8.062	0.016	4.76	Some drips missing funnel.
A1X02	12/04/85	14:07	00.14	337.588	13.140	0.011	4.90	Sample for chemical analysis, #12.
A1X02	12/10/85	10:31	00.08	343.438	5.850	0.014	4.98	
A1X02	12/17/85	13:56	00.03	350.581	7.143	0.004	5.01	
A1X02	01/03/86	09:40	00.01	367.403	16.822	0.001	5.02	Some drips missing funnel.

TABLE A-2 (Continued)
BRINE ACCUMULATION DATA TABLE
 Data through December 31, 1993

LOCATION	DATE	TIME	LITERS REMOVED	DAYS SINCE 1/1/85	DAYS USED FOR CALCULATION	LITERS PER DAY	CUMULATIVE LITERS COLLECTED	REMARKS
A1X02	01/23/86	10:10	00.06	387.424	20.021	0.003	5.08	New, larger funnel since 01/17.
A1X02	01/31/86	11:05	00.23	395.462	8.038	0.029	5.31	
A1X02	02/12/86	10:10	00.22	407.424	11.962	0.018	5.53	
A1X02	02/19/86	10:50	00.07	414.451	7.027	0.010	5.60	
A1X02	02/28/86	14:00	00.02	423.583	9.132	0.002	5.62	
A1X02	03/13/86	09:30	00.05	436.396	12.813	0.004	5.67	
A1X02	03/26/86	09:20	00.05	449.389	12.993	0.004	5.72	
A1X02	04/02/86	09:00	00.08	456.375	6.986	0.011	5.80	
A1X02	04/16/86	11:30	00.10	470.479	14.104	0.007	5.90	Sample for chemical analysis, #2.
A1X02	04/24/86	09:35	00.05	478.399	7.920	0.006	5.95	Sample for chemistry.
A1X02	04/30/86	10:10	00.07	484.424	6.025	0.012	6.02	Sample for chemistry.
A1X02	05/06/86	09:40	00.16	490.403	5.979	0.027	6.18	
A1X02	05/13/86	09:25	00.02	497.392	6.989	0.003	6.20	Sample for chemistry.
A1X02	05/20/86	10:16	00.04	504.428	7.036	0.006	6.24	
A1X02	05/27/86	15:05	00.15	511.628	7.200	0.021	6.39	
A1X02	06/03/86	09:28	00.13	518.394	6.766	0.019	6.52	
A1X02	06/10/86	10:50	00.10	525.451	7.057	0.014	6.62	
A1X02	06/17/86	09:59	00.12	532.416	6.965	0.017	6.74	
A1X02	06/24/86	10:10	00.25	539.424	7.008	0.036	6.99	
A1X02	07/01/86	12:44	00.23	546.531	7.107	0.032	7.22	
A1X02	07/08/86	10:05	00.11	553.420	6.889	0.016	7.33	
A1X02	07/16/86	09:54	00.25	561.413	7.993	0.031	7.58	
A1X02	07/22/86	09:26	00.16	567.393	5.980	0.027	7.74	
A1X02	07/29/86	10:05	00.26	574.420	7.027	0.037	8.00	
A1X02	08/05/86	10:19	00.22	581.430	7.010	0.031	8.22	
A1X02	08/12/86	09:58	00.28	588.415	6.985	0.040	8.50	
A1X02	08/19/86	10:38	00.26	595.443	7.028	0.037	8.76	
A1X02	08/26/86	10:07	00.24	602.422	6.979	0.034	9.00	Sample #6.
A1X02	09/04/86	10:01	00.35	611.417	8.995	0.039	9.35	
A1X02	09/09/86	10:25	00.17	616.434	5.017	0.034	9.52	
A1X02	09/16/86	09:35	00.27	623.399	6.965	0.039	9.79	
A1X02	09/23/86	09:39	00.26	630.402	7.003	0.037	10.05	
A1X02	10/01/86	11:39	00.24	638.485	8.083	0.030	10.29	
A1X02	10/08/86	10:32	00.17	645.439	6.954	0.024	10.46	
A1X02	10/14/86	10:53	00.13	651.453	6.014	0.022	10.59	
A1X02	11/05/86	10:30	0.30	673.438	21.985	0.014	10.89	
A1X02	11/20/86	11:43	00.11	688.488	15.050	0.007	11.00	
A1X02	12/31/86	12:10	00.14	729.507	41.019	0.003	11.14	Low readings from 11/20/86 to 6/20/87 may be due to blockage in collecting system.
A1X02	02/03/87	12:16	NA	763.511	0.000	0.000	11.14	
A1X02	03/06/87	11:55	0.05	794.497	64.990	0.001	11.19	
A1X02	03/30/87	11:55	0.01	818.497	24.000	0.000	11.20	Tubing plugged, unable to open.
A1X02	05/07/87	10:45	0.01	856.448	37.951	0.000	11.21	Tubing plugged, unable to open.
A1X02	06/30/87	12:00	1.58	910.500	54.052	0.029	12.79	Removed metal funnel, which was plugged. Most of the brine collected was in the funnel. Installed a large plastic funnel.
A1X02	07/28/87	11:45	0.85	938.490	27.990	0.030	13.64	Collected for chemistry, sample #148.

TABLE A-2 (Continued)
BRINE ACCUMULATION DATA TABLE
 Data through December 31, 1993

LOCATION	DATE	TIME	LITERS REMOVED	DAYS	DAYS	LITERS PER DAY	CUMULATIVE LITERS COLLECTED	REMARKS
				SINCE 1/1/85	USED FOR CALCULATION			
A1X02	09/01/87	11:55	0.94	973.497	35.007	0.027	14.58	Collected for chemistry, sample #159 A&B.
A1X02	10/20/87	10:59	1.84	1022.458	48.961	0.038	16.42	
A1X02	11/19/87	10:30	1.09	1052.438	29.980	0.036	17.51	Collected for chemistry, sample 226.
A1X02	01/04/88	11:05	3.73	1098.462	46.024	0.081	21.24	
A1X02	02/08/88	13:17	1.65	1133.553	35.091	0.047	22.89	Collected for chemistry, sample #299, #300, #301 & #302.
A1X02	03/30/88	12:20	4.86	1184.514	50.961	0.095	27.75	Collected for chemistry, sample #343 - #352.
A1X02	06/14/88	09:00	5.15	1260.375	75.861	0.068	32.90	Collected for chemistry, sample #402 - #406. Removed to provide room for further collection.
A1X02	07/12/88	09:30	1.11	1288.396	28.021	0.040	34.01	Collected for chemistry, sample #458 & #459.
A1X02	09/15/88	11:00	0.18	1353.458	0.000	0.000	34.19	Not fully evacuated. Do not use for calculation.
A1X02	09/27/88	08:30	3.00	1365.354	76.958	0.041	37.19	Collected for chemistry, sample #514 - #519. Used 3.18 liters for calculation (0.18 on 9/15 + 3.00 on 9/27).
A1X02	12/13/88	09:30	2.50	1442.396	77.042	0.032	39.69	Collected for chemistry, sample #597 - #601.
A1X02	03/14/89	09:30	2.96	1533.396	91.000	0.033	42.65	
A1X02	04/06/89	11:55	NA	1556.497	0.000	0.000	42.65	Room locked.
A1X02	04/20/89	10:00	NA	1570.417	0.000	0.000	42.65	Room locked.
A1X02	05/17/89	12:05	4.47	1597.503	64.107	0.070	47.12	Sample saved for chemistry, sample #750 - 751 A & B.
A1X02	07/11/89	10:05	2.32	1652.420	54.917	0.042	49.44	
A1X02	09/12/89	11:35	2.77	1715.483	63.063	0.044	52.21	Sample saved for chemistry.
A1X02	10/10/89	09:25	1.57	1743.392	27.909	0.056	53.78	Sample saved for chemistry, sample #847.
A1X02	10/10/89	10:00	NA	1743.417	0.000	0.000	53.78	Repositioned collecting tube from funnel. Collection point for brine located outside room.
A1X02	10/20/89	10:44	NA	1753.447	0.000	0.000	53.78	No sample.
A1X02	11/10/89	10:08	1.90	1774.422	31.030	0.061	55.68	Sample saved for chemistry, sample #862-1,2,3,4.
A1X02	11/29/89	12:10	0.53	1793.507	19.085	0.028	56.21	Sample saved for chemistry, sample #873.
A1X02	12/12/89	09:20	0.05	1806.389	12.882	0.004	56.26	Sample saved for chemistry, sample #884.
A1X02	01/04/90	10:50	0.22	1829.451	23.062	0.010	56.48	Hose broken, some brine leaked to floor. Fixed hose, funnel full of brine.
A1X02	01/17/90	11:35	1.20	1842.483	13.032	0.092	57.68	
A1X02	01/31/90	10:27	0.53	1856.435	13.952	0.038	58.21	
A1X02	02/13/90	09:53	0.29	1869.412	12.977	0.022	58.50	
A1X02	02/27/90	12:17	0.45	1883.512	14.100	0.032	58.95	
A1X02	03/05/90	11:11	0.58	1889.466	5.954	0.097	59.53	
A1X02	03/21/90	11:26	0.18	1905.476	16.010	0.011	59.71	
A1X02	04/06/90	10:40	0.34	1921.444	15.968	0.021	60.05	
A1X02	04/17/90	11:53	0.17	1932.495	11.051	0.015	60.22	
A1X02	04/24/90	10:40	0.01	1939.444	6.949	0.001	60.23	

TABLE A-2 (Continued)
BRINE ACCUMULATION DATA TABLE
 Data through December 31, 1993

LOCATION	DATE	TIME	LITERS REMOVED	DAYS SINCE 1/1/85	DAYS USED FOR CALCULATION	LITERS PER DAY	CUMULATIVE LITERS COLLECTED	REMARKS
A1X02	05/02/90	11:49	0.23	1947.492	8.048	0.029	60.46	
A1X02	05/09/90	11:13	0.19	1954.467	6.975	0.027	60.65	
A1X02	05/16/90	10:49	0.23	1961.451	6.984	0.033	60.88	
A1X02	05/23/90	12:32	0.20	1968.522	7.071	0.028	61.08	
A1X02	05/31/90	10:29	0.25	1976.437	7.915	0.032	61.33	
A1X02	06/06/90	11:20	0.13	1982.472	6.035	0.022	61.46	
A1X02	06/14/90	09:51	0.11	1990.410	7.938	0.014	61.57	
A1X02	06/28/90	10:08	0.24	2004.422	14.012	0.017	61.81	
A1X02	07/14/90	10:00	NA	2020.417	0.000	0.000	61.81	Heaters turned off.
A1X02	07/17/90	09:51	0.23	2023.410	18.988	0.012	62.04	
A1X02	07/25/90	08:30	0.15	2031.354	7.944	0.019	62.19	
A1X02	08/07/90	10:53	0.32	2044.453	13.099	0.024	62.51	
A1X02	08/16/90	11:30	0.11	2053.479	9.026	0.012	62.62	
A1X02	08/22/90	11:52	0.25	2059.494	6.015	0.042	62.87	
A1X02	08/29/90	12:52	0.32	2066.536	7.042	0.045	63.19	
A1X02	09/05/90	11:50	0.27	2073.493	6.957	0.039	63.46	
A1X02	09/13/90	09:58	0.33	2081.415	7.922	0.042	63.79	
A1X02	09/25/90	12:15	0.46	2093.510	12.095	0.038	64.25	
A1X02	10/03/90	10:03	0.28	2101.419	7.909	0.035	64.53	
A1X02	10/10/90	11:43	0.25	2108.488	7.069	0.035	64.78	
A1X02	10/18/90	11:04	0.31	2116.461	7.973	0.039	65.09	
A1X02	10/24/90	12:22	0.20	2122.515	6.054	0.033	65.29	
A1X02	10/31/90	11:50	0.22	2129.493	6.978	0.032	65.51	
A1X02	11/07/90	10:56	0.23	2136.456	6.963	0.033	65.74	
A1X02	11/14/90	11:54	0.20	2143.496	7.040	0.028	65.94	
A1X02	11/28/90	10:56	0.47	2157.456	13.960	0.034	66.41	
A1X02	12/05/90	09:02	0.21	2164.376	6.920	0.030	66.62	
A1X02	12/13/90	09:45	0.27	2172.406	8.030	0.034	66.89	
A1X02	12/20/90	09:04	0.24	2179.378	6.972	0.034	67.13	
A1X02	01/09/91	09:10	0.71	2199.382	20.004	0.035	67.84	
A1X02	01/16/91	09:25	0.28	2206.392	7.010	0.040	68.12	
A1X02	01/23/91	10:20	0.26	2213.431	7.039	0.037	68.38	
A1X02	01/30/91	10:34	0.27	2220.440	7.009	0.039	68.65	
A1X02	02/13/91	11:40	0.50	2234.486	14.046	0.036	69.15	
A1X02	02/20/91	10:55	0.26	2241.455	6.969	0.037	69.41	
A1X02	02/27/91	10:35	0.24	2248.441	6.986	0.034	69.65	
A1X02	03/07/91	10:30	0.26	2256.438	7.997	0.033	69.91	
A1X02	03/20/91	11:31	0.35	2269.480	13.042	0.027	70.26	
A1X02	03/28/91	11:13	0.15	2277.467	7.987	0.019	70.41	
A1X02	04/10/91	09:30	0.30	2290.396	12.929	0.023	70.71	
A1X02	05/14/91	09:57	1.58	2324.415	0.000	0.000	72.29	Partial evacuation.
A1X02	05/15/91	10:36	0.12	2325.442	35.046	0.049	72.41	Combined with 1.58 liters from 05/14/91.
A1X02	05/30/91	12:15	0.62	2340.510	15.068	0.041	73.03	
A1X02	06/05/91	14:18	0.20	2346.596	6.086	0.033	73.23	
A1X02	06/12/91	10:51	0.25	2353.452	6.856	0.036	73.48	
A1X02	06/19/91	15:10	0.25	2360.632	7.180	0.035	73.73	
A1X02	06/26/91	09:50	0.24	2367.410	6.778	0.035	73.97	

TABLE A-2 (Continued)
BRINE ACCUMULATION DATA TABLE
 Data through December 31, 1993

LOCATION	DATE	TIME	LITERS REMOVED	DAYS	DAYS	LITERS PER DAY	CUMULATIVE	REMARKS
				SINCE 1/1/85	USED FOR CALCULATION		LITERS COLLECTED	
A1X02	07/11/91	11:01	0.65	2382.459	15.049	0.043	74.62	
A1X02	07/17/91	10:15	0.26	2388.427	5.968	0.044	74.88	
A1X02	07/30/91	09:55	0.49	2401.413	12.986	0.038	75.37	
A1X02	08/08/91	08:35	0.32	2410.358	8.945	0.036	75.69	
A1X02	08/14/91	09:32	0.15	2416.397	6.039	0.025	75.84	
A1X02	08/21/91	09:40	0.39	2423.403	7.006	0.056	76.23	
A1X02	08/28/91	09:06	0.29	2430.379	6.976	0.042	76.52	
A1X02	09/04/91	10:15	0.16	2437.427	7.048	0.023	76.68	
A1X02	09/11/91	11:15	0.43	2444.469	7.042	0.061	77.11	
A1X02	10/02/91	10:30	1.15	2465.438	20.969	0.055	78.26	
A1X02	10/16/91	10:35	0.73	2479.441	14.003	0.052	78.99	
A1X02	10/31/91	10:28	0.68	2494.436	14.995	0.045	79.67	
A1X02	11/06/91	11:40	0.12	2500.486	6.050	0.020	79.79	
A1X02	11/13/91	10:10	0.11	2507.424	6.938	0.016	79.90	
A1X02	11/20/91	09:45	0.04	2514.406	6.982	0.006	79.94	
A1X02	11/27/91	08:55	0.02	2521.372	6.966	0.003	79.96	
A1X02	12/04/91	10:25	0.05	2528.434	7.062	0.007	80.01	
A1X02	12/11/91	10:20	0.05	2535.431	6.997	0.007	80.06	
A1X02	12/18/91	10:20	0.02	2542.431	7.000	0.003	80.08	
A1X02	01/08/92	09:09	0.04	2563.381	20.950	0.002	80.12	
A1X02	02/12/92	09:20	0.15	2598.389	35.008	0.004	80.27	
A1X02	02/26/92	08:55	0.06	2612.372	13.983	0.004	80.33	
A1X02	04/22/92	09:57	0.05	2668.415	56.043	0.001	80.38	
A1X02	05/06/92	10:15		2682.427	14.012	0.000	80.38	
A1X02	05/21/92	11:06	0.0	2697.463	15.036	0.000	80.38	Bucket is empty.
A1X02	07/29/92	10:20	0.22	2766.431	68.968	0.003	80.60	
A1X02	08/18/92	09:33	0.52	2786.398	19.967	0.026	81.12	Hole has returned to normal, restriction seems to have corrected itself.
A1X02	09/02/92	09:35	0.49	2801.399	15.001	0.033	81.61	
A1X02	09/09/92	09:32	0.25	2808.397	6.998	0.036	81.86	
A1X02	09/17/92	10:00	0.22	2816.417	8.020	0.027	82.08	
A1X02	09/23/92	09:40	0.01	2822.403	5.986	0.002	82.09	
A1X02	09/30/92	10:25	0.01	2829.434	7.031	0.001	82.10	
A1X02	10/12/92	13:00	0.05	2841.542	12.108	0.004	82.15	
A1X02	10/21/92	12:35	Trace	2850.524	0.000	0.000	82.15	Did not remove trace.
A1X02	10/28/92	08:40	Trace	2857.361	0.000	0.000	82.15	Did not remove trace.
A1X02	11/25/92	10:05	Trace	2885.420	0.000	0.000	82.15	Did not remove trace.
A1X02	01/07/93	09:25	0.12	2928.392	86.850	0.001	82.27	
A1X02	02/11/93	09:20	0.00	2963.389	34.997	0.000	82.27	Bucket empty.
A1X02	04/28/93	10:45	0.00	3039.448	76.059	0.000	82.27	
A1X02	06/16/93	09:35	1.02	3088.399	48.951	0.021	83.29	
A1X02	08/19/93	13:30		3152.563	0.000	0.000	83.29	0.50 liters of urine. Last time sampled.
A3X01	11/06/84	00:00	NA	0.000	0.000	0.000	0.00	Room A3 completed.
A3X01	01/14/85	00:00	NA	13.000	0.000	0.000	0.00	Downhole drilled 12/20/85 to 1/14/85.
A3X01	02/05/85	11:10	NA	35.465	0.000	0.000	0.00	Moist muck at the bottom.

TABLE A-2 (Continued)
BRINE ACCUMULATION DATA TABLE
 Data through December 31, 1993

LOCATION	DATE	TIME	LITERS REMOVED	DAYS SINCE 1/1/85	DAYS USED FOR CALCULATION	LITERS PER DAY	CUMULATIVE LITERS COLLECTED	REMARKS
A3X01	02/19/85	13:40	00.30	49.569	14.104	0.021	0.30	Some oil. First time collected.
A3X01	02/26/85	13:20	00.23	56.556	6.987	0.033	0.53	Brine and oil.
A3X01	03/07/85	09:45	00.26	65.406	8.850	0.029	0.79	
A3X01	03/12/85	11:45	00.17	70.490	5.084	0.033	0.96	
A3X01	03/20/85	13:14	00.19	78.551	8.061	0.024	1.15	Valved leaked, some brine drained back down hole.
A3X01	03/26/85	11:12	00.22	84.467	5.916	0.037	1.37	
A3X01	04/02/85	12:00	00.21	91.500	7.033	0.030	1.58	
A3X01	04/10/85	12:00	00.23	99.500	8.000	0.029	1.81	
A3X01	04/17/85	11:20	00.20	106.472	6.972	0.029	2.01	
A3X01	04/23/85	10:41	00.16	112.445	5.973	0.027	2.17	
A3X01	04/30/85	13:35	00.20	119.566	7.121	0.028	2.37	
A3X01	05/07/85	08:55	00.20	126.372	6.806	0.029	2.57	
A3X01	05/14/85	09:56	00.17	133.414	7.042	0.024	2.74	
A3X01	05/21/85	12:00	00.20	140.500	7.086	0.028	2.94	
A3X01	05/29/85	09:25	00.21	148.392	7.892	0.027	3.15	
A3X01	06/04/85	09:55	00.16	154.413	6.021	0.027	3.31	
A3X01	06/11/85	09:25	00.18	161.392	6.979	0.026	3.49	
A3X01	06/18/85	09:27	00.18	168.394	7.002	0.026	3.67	
A3X01	06/25/85	09:30	00.19	175.396	7.002	0.027	3.86	
A3X01	07/02/85	11:00	00.19	182.458	7.062	0.027	4.05	
A3X01	07/09/85	09:50	00.17	189.410	6.952	0.024	4.22	
A3X01	07/16/85	10:50	00.18	196.451	7.041	0.026	4.40	Brine effervesces.
A3X01	07/24/85	09:47	00.21	204.408	7.957	0.026	4.61	
A3X01	07/30/85	09:30	00.15	210.396	5.988	0.025	4.76	
A3X01	08/06/85	09:30	00.17	217.396	7.000	0.024	4.93	
A3X01	08/14/85	09:21	00.20	225.390	7.994	0.025	5.13	
A3X01	08/20/85	10:08	00.16	231.422	6.032	0.027	5.29	
A3X01	08/28/85	09:05	00.21	239.378	7.956	0.026	5.50	
A3X01	09/04/85	09:29	00.17	246.395	7.017	0.024	5.67	
A3X01	09/10/85	09:20	00.15	252.389	5.994	0.025	5.82	
A3X01	09/17/85	09:06	00.16	259.379	6.990	0.023	5.98	
A3X01	09/24/85	09:03	00.17	266.377	6.998	0.024	6.15	
A3X01	10/01/85	09:18	00.18	273.388	7.011	0.026	6.33	
A3X01	10/08/85	12:35	00.18	280.524	7.136	0.025	6.51	Room A3 heaters turned on 10/02/85.
A3X01	10/15/85	09:35	00.16	287.399	6.875	0.023	6.67	
A3X01	10/23/85	09:40	00.19	295.403	8.004	0.024	6.86	
A3X01	10/29/85	11:11	00.14	301.466	6.063	0.023	7.00	
A3X01	11/05/85	08:42	00.16	308.363	6.897	0.023	7.16	
A3X01	11/13/85	09:30	00.19	316.396	8.033	0.024	7.35	
A3X01	11/21/85	10:30	00.19	324.438	8.042	0.024	7.54	
A3X01	11/26/85	09:55	00.10	329.413	4.975	0.020	7.64	
A3X01	12/04/85	14:03	00.18	337.585	8.172	0.022	7.82	Sample for chemical analysis, #10.
A3X01	12/10/85	10:46	00.14	343.449	5.864	0.024	7.96	
A3X01	12/17/85	13:55	00.14	350.580	7.131	0.020	8.10	
A3X01	01/03/86	10:00	00.39	367.417	16.837	0.023	8.49	
A3X01	01/08/86	10:10	00.11	372.424	5.007	0.022	8.60	

TABLE A-2 (Continued)
BRINE ACCUMULATION DATA TABLE
 Data through December 31, 1993

LOCATION	DATE	TIME	LITERS REMOVED	DAYS	DAYS	LITERS PER DAY	CUMULATIVE	REMARKS
				SINCE 1/1/85	USED FOR CALCULATION		LITERS COLLECTED	
A3X01	01/16/86	09:35	00.18	380.399	7.975	0.023	8.78	
A3X01	01/23/86	10:00	00.15	387.417	7.018	0.021	8.93	
A3X01	01/31/86	10:55	00.18	395.455	8.038	0.022	9.11	
A3X01	02/12/86	10:00	00.27	407.417	11.962	0.023	9.38	
A3X01	02/19/86	10:40	00.15	414.444	7.027	0.021	9.53	
A3X01	02/28/86	14:20	00.22	423.597	9.153	0.024	9.75	
A3X01	03/06/86	09:50	00.14	429.410	5.813	0.024	9.89	
A3X01	03/13/86	09:20	00.15	436.389	6.979	0.021	10.04	
A3X01	03/26/86	09:15	00.30	449.385	12.996	0.023	10.34	
A3X01	04/02/86	08:50	00.16	456.368	6.983	0.023	10.50	
A3X01	04/08/86	09:05	00.14	462.378	6.010	0.023	10.64	
A3X01	04/16/86	11:25	00.18	470.476	8.098	0.022	10.82	
A3X01	04/24/86	09:30	00.18	478.396	7.920	0.023	11.00	
A3X01	04/30/86	10:00	00.14	484.417	6.021	0.023	11.14	
A3X01	05/06/86	09:35	00.14	490.399	5.982	0.023	11.28	
A3X01	05/13/86	09:20	00.15	497.389	6.990	0.021	11.43	
A3X01	05/20/86	10:10	00.15	504.424	7.035	0.021	11.58	
A3X01	05/27/86	15:00	00.16	511.625	7.201	0.022	11.74	
A3X01	06/03/86	09:20	00.15	518.389	6.764	0.022	11.89	
A3X01	06/10/86	10:42	00.16	525.446	7.057	0.023	12.05	
A3X01	06/17/86	09:51	00.12	532.410	6.964	0.017	12.17	Sample for brine chemistry, #18.
A3X01	06/24/86	10:05	00.16	539.420	7.010	0.023	12.33	
A3X01	07/01/86	12:35	00.16	546.524	7.104	0.023	12.49	
A3X01	07/08/86	09:57	00.15	553.415	6.891	0.022	12.64	
A3X01	07/16/86	09:47	00.19	561.408	7.993	0.024	12.83	
A3X01	07/22/86	09:23	00.14	567.391	5.983	0.023	12.97	
A3X01	07/29/86	10:00	00.14	574.417	7.026	0.020	13.11	
A3X01	08/05/86	10:15	00.18	581.427	7.010	0.026	13.29	
A3X01	08/12/86	09:50	00.16	588.410	6.983	0.023	13.45	
A3X01	08/19/86	10:35	00.16	595.441	7.031	0.023	13.61	
A3X01	08/26/86	10:00	00.15	602.417	6.976	0.022	13.76	Static level not measured.
A3X01	09/04/86	09:52	00.20	611.411	8.994	0.022	13.96	Sample # 16.
A3X01	09/09/86	10:35	00.12	616.441	5.030	0.024	14.08	
A3X01	09/16/86	09:29	00.14	623.395	6.954	0.020	14.22	
A3X01	09/23/86	09:36	00.18	630.400	7.005	0.026	14.40	
A3X01	10/01/86	11:30	00.19	638.479	8.079	0.024	14.59	
A3X01	10/08/86	10:24	00.14	645.433	6.954	0.020	14.73	
A3X01	10/14/86	10:47	00.12	651.449	6.016	0.020	14.85	
A3X01	11/05/86	10:20	0.52	673.431	21.982	0.024	15.37	
A3X01	11/20/86	11:33	00.33	688.481	15.050	0.022	15.70	
A3X01	12/31/86	11:45	00.88	729.490	41.009	0.021	16.58	
A3X01	02/03/87	12:00	00.73	763.500	34.010	0.021	17.31	
A3X01	03/06/87	11:45	0.68	794.490	30.990	0.022	17.99	
A3X01	03/30/87	12:00	0.55	818.500	24.010	0.023	18.54	
A3X01	05/07/87	10:39	0.80	856.444	37.944	0.021	19.34	
A3X01	06/17/87	11:25	0.89	897.476	41.032	0.022	20.23	Collected for chemistry, samples #126A, #126B.

TABLE A-2 (Continued)
BRINE ACCUMULATION DATA TABLE
 Data through December 31, 1993

LOCATION	DATE	TIME	LITERS REMOVED	DAYS SINCE 1/1/85	DAYS USED FOR CALCULATION	LITERS PER DAY	CUMULATIVE LITERS COLLECTED	REMARKS
A3X01	07/28/87	12:02	0.92	938.501	41.025	0.022	21.15	
A3X01	09/01/87	11:45	0.77	973.490	34.989	0.022	21.92	Collected for chemistry, sample #172 A&B.
A3X01	10/20/87	10:55	1.10	1022.455	48.965	0.022	23.02	
A3X01	11/19/87	10:20	0.66	1052.431	29.976	0.022	23.68	Collected for chemistry, sample #220.
A3X01	01/04/88	11:00	1.01	1098.458	46.027	0.022	24.69	
A3X01	02/08/88	13:30	0.67	1133.563	35.105	0.019	25.36	Collected for chemistry, sample #297 & #298.
A3X01	03/30/88	12:10	1.02	1184.507	50.944	0.020	26.38	Collected for chemistry, sample #387 & #388.
A3X01	05/12/88	10:20	0.88	1227.431	42.924	0.021	27.26	Sampled for SNL/NM PA.
A3X01	07/12/88	09:40	1.28	1288.403	60.972	0.021	28.54	Collected for chemistry, sample #456 & #457.
A3X01	09/27/88	08:20		1365.347	0.000	0.000	28.54	Cannot be sampled. Room has bad back.
A3X01	12/13/88	09:25	3.35	1442.392	153.989	0.022	31.89	Collected for chemistry, sample #591 - #596.
A3X01	03/14/89	09:15	1.90	1533.385	90.993	0.021	33.79	Collected for chemistry, sample #656 - 659.
A3X01	04/06/89	12:04	NA	1556.503	0.000	0.000	33.79	Room locked.
A3X01	04/20/89	10:00	NA	1570.417	0.000	0.000	33.79	Room locked.
A3X01	05/17/89	11:45	1.42	1597.490	64.105	0.022	35.21	Collected for chemistry, sample #758 A & B.
A3X01	07/11/89	09:55	0.93	1652.413	54.923	0.017	36.14	
A3X01	09/12/89	11:26	1.51	1715.476	63.063	0.024	37.65	Sample saved for chemistry.
A3X01	10/10/89	09:43	NA	1743.405	0.000	0.000	37.65	Installed collection device. Collection point for brine located outside room.
A3X01	10/20/89	10:39	0.36	1753.444	37.968	0.009	38.01	Collected for chemistry, sample #850.
A3X01	11/10/89	09:40	0.50	1774.403	20.959	0.024	38.51	Collected for chemistry, sample #860-1.
A3X01	11/29/89	11:56	0.63	1793.497	19.094	0.033	39.14	Collected for chemistry, sample #871.
A3X01	12/12/89	09:00	0.43	1806.375	12.878	0.033	39.57	Collected for chemistry, sample #882.
A3X01	01/04/90	10:00	0.50	1829.417	23.042	0.022	40.07	
A3X01	01/17/90	11:24	0.25	1842.475	13.058	0.019	40.32	
A3X01	01/31/90	09:40	0.24	1856.403	13.928	0.017	40.56	
A3X01	02/13/90	09:21	0.31	1869.390	12.987	0.024	40.87	
A3X01	02/27/90	11:43	0.32	1883.488	14.098	0.023	41.19	
A3X01	03/05/90	10:45	0.30	1889.448	5.960	0.050	41.49	
A3X01	03/21/90	11:15	0.15	1905.469	16.021	0.009	41.64	Brine probably left in hole.
A3X01	04/06/90	10:29	0.35	1921.437	15.968	0.022	41.99	
A3X01	04/17/90	11:13	0.13	1932.467	11.030	0.012	42.12	
A3X01	04/24/90	10:26	0.02	1939.435	0.000	0.000	42.14	
A3X01	04/25/90	09:35	0.15	1940.399	7.932	0.021	42.29	Reinstalled sampler. Combined with 0.02 liters from 04/24/90. Used 0.17 liters for calculation.
A3X01	05/02/90	11:20	0	1947.472	0.000	0.000	42.29	Could not sample.
A3X01	05/16/90	10:26	NA	1961.435	0.000	0.000	42.29	Sampler malfunction.
A3X01	05/23/90	12:35	0.08	1968.524	28.125	0.003	42.37	
A3X01	05/31/90	10:51	0.14	1976.452	7.928	0.018	42.51	
A3X01	06/01/90	10:25	NA	1977.434	0.000	0.000	42.51	Replaced sampler.
A3X01	06/06/90	11:06	0.49	1982.463	6.011	0.082	43.00	
A3X01	06/14/90	08:38	0.17	1990.360	7.897	0.022	43.17	

TABLE A-2 (Continued)
BRINE ACCUMULATION DATA TABLE
 Data through December 31, 1993

LOCATION	DATE	TIME	LITERS REMOVED	DAYS SINCE 1/1/85	DAYS USED FOR CALCULATION	LITERS PER DAY	CUMULATIVE LITERS COLLECTED	REMARKS
A3X01	07/17/90	10:18	0.60	2023.429	0.000	0.000	43.77	
A3X01	07/18/90	10:11	0.09	2024.424	34.064	0.020	43.86	Combined with 0.60 liters from 07/17/90. Used 0.69 liters for calculation.
A3X01	07/25/90	08:20	0.70	2031.347	0.000	0.000	44.56	
A3X01	08/07/90	11:21	0.24	2044.473	20.049	0.047	44.80	Combined with 0.7 liters from 07/25/90. Used 0.94 liters for calculation.
A3X01	08/16/90	11:11	0.27	2053.466	8.993	0.030	45.07	
A3X01	08/22/90	11:42	0.15	2059.488	6.022	0.025	45.22	
A3X01	08/23/90	10:00	NA	2060.417	0.000	0.000	45.22	Heaters turned off.
A3X01	08/29/90	12:44	0.16	2066.531	7.043	0.023	45.38	
A3X01	09/05/90	11:35	0.15	2073.483	6.952	0.022	45.53	
A3X01	09/13/90	09:56	0.18	2081.414	7.931	0.023	45.71	
A3X01	09/25/90	12:34	0.25	2093.524	12.110	0.021	45.96	
A3X01	09/26/90	11:09	0.02	2094.465	0.941	0.021	45.98	
A3X01	10/03/90	09:50	0.16	2101.410	6.945	0.023	46.14	
A3X01	10/10/90	11:40	0.15	2108.486	7.076	0.021	46.29	
A3X01	10/18/90	10:53	0.16	2116.453	7.967	0.020	46.45	
A3X01	10/24/90	12:08	0.14	2122.506	6.053	0.023	46.59	
A3X01	10/31/90	11:35	0.16	2129.483	6.977	0.023	46.75	
A3X01	11/07/90	10:52	0.15	2136.453	6.970	0.022	46.90	
A3X01	11/14/90	11:50	0.15	2143.493	7.040	0.021	47.05	
A3X01	11/28/90	10:51	0.30	2157.452	13.959	0.021	47.35	
A3X01	12/05/90	08:55	0.15	2164.372	6.920	0.022	47.50	
A3X01	12/13/90	09:35	0.17	2172.399	8.027	0.021	47.67	
A3X01	12/20/90	08:56	0.18	2179.372	6.973	0.026	47.85	
A3X01	01/09/91	09:07	0.39	2199.380	20.008	0.019	48.24	
A3X01	01/16/91	09:15	0.16	2206.385	7.005	0.023	48.40	
A3X01	01/23/91	10:05	0.15	2213.420	7.035	0.021	48.55	
A3X01	01/30/91	10:16	0.16	2220.428	7.008	0.023	48.71	
A3X01	02/13/91	11:22	0.36	2234.474	14.046	0.026	49.07	
A3X01	02/20/91	10:45	0.16	2241.448	6.974	0.023	49.23	
A3X01	02/27/91	10:20	0.14	2248.431	6.983	0.020	49.37	
A3X01	03/07/91	10:15	0.26	2256.427	7.996	0.033	49.63	
A3X01	03/20/91	11:21	0.28	2269.473	13.046	0.021	49.91	
A3X01	03/28/91	11:07	0.18	2277.463	7.990	0.023	50.09	
A3X01	04/10/91	09:19	0.26	2290.388	12.925	0.020	50.35	
A3X01	05/14/91	09:50	0.34	2324.410	0.000	0.000	50.69	Partial evacuation.
A3X01	05/15/91	10:20	0.30	2325.431	35.043	0.018	50.99	Combined with 0.34 liters from 05/14/91.
A3X01	05/30/91	11:45	0.31	2340.490	15.059	0.021	51.30	
A3X01	06/05/91	14:22	0.16	2346.599	6.109	0.026	51.46	
A3X01	06/12/91	10:50	0.15	2353.451	6.852	0.022	51.61	
A3X01	06/19/91	15:12	0.15	2360.633	7.182	0.021	51.76	
A3X01	06/26/91	09:45	0.14	2367.406	6.773	0.021	51.90	
A3X01	07/11/91	11:16	0.30	2382.469	15.063	0.020	52.20	
A3X01	07/17/91	10:10	0.15	2388.424	5.955	0.025	52.35	
A3X01	07/30/91	09:50	0.40	2401.410	12.986	0.031	52.75	
A3X01	08/08/91	08:30	0.24	2410.354	8.944	0.027	52.99	

TABLE A-2 (Continued)
BRINE ACCUMULATION DATA TABLE
 Data through December 31, 1993

LOCATION	DATE	TIME	LITERS REMOVED	DAYS SINCE 1/1/85	DAYS USED FOR CALCULATION	LITERS PER DAY	CUMULATIVE LITERS COLLECTED	REMARKS
A3X01	08/14/91	09:25	0.13	2416.392	6.038	0.022	53.12	
A3X01	08/21/91	09:22	0.15	2423.390	6.998	0.021	53.27	
A3X01	08/28/91	08:53	0.13	2430.370	6.980	0.019	53.40	
A3X01	09/04/91	10:14	0.22	2437.426	7.056	0.031	53.62	
A3X01	09/11/91	11:10	0.17	2444.465	7.039	0.024	53.79	
A3X01	10/02/91	10:25	0.13	2465.434	20.969	0.006	53.92	
A3X01	10/16/91	10:25	0.48	2479.434	14.000	0.034	54.40	
A3X01	10/31/91	10:40	0.01	2494.444	0.000	0.000	54.41	Some brine may have been left in hole. Lost vacuum prior to sampling.
A3X01	11/06/91	11:35	0.06	2500.483	0.000	0.000	54.47	Some brine may have been left in hole. Line clogged.
A3X01	11/20/91	9:30	0.53	2514.375	34.941	0.017	55.00	Combined with 0.01 liters from 10/31/91 and 0.06 liters from 11/06/91.
A3X01	11/27/91	09:04	0.21	2521.378	7.003	0.030	55.21	
A3X01	12/04/91	10:20	0.17	2528.431	7.053	0.024	55.38	
A3X01	12/11/91	10:15	0.13	2535.427	6.996	0.019	55.51	
A3X01	12/18/91	10:15	0.17	2542.427	7.000	0.024	55.68	
A3X01	12/23/91	09:10	0.14	2547.382	4.955	0.028	55.82	
A3X01	01/08/92	09:05	0.15	2563.378	15.996	0.009	55.97	
A3X01	01/15/92	09:21	0.35	2570.390	7.012	0.050	56.32	
A3X01	01/22/92	09:45	0.15	2577.406	7.016	0.021	56.47	
A3X01	01/29/92	10:26	0.14	2584.435	7.029	0.020	56.61	
A3X01	02/12/92	09:15	0.38	2598.385	13.950	0.027	56.99	
A3X01	02/19/92	10:00	0.14	2605.417	7.032	0.020	57.13	
A3X01	02/26/92	08:45	0.15	2612.365	6.948	0.022	57.28	
A3X01	03/11/92	08:55	0.28	2626.372	14.007	0.020	57.56	
A3X01	03/18/92	08:40	0.16	2633.361	6.989	0.023	57.72	
A3X01	03/25/92	09:55	0.14	2640.413	7.052	0.020	57.86	
A3X01	04/01/92	09:50	0.15	2647.410	6.997	0.021	58.01	
A3X01	04/07/92	09:55	0.12	2653.413	6.003	0.020	58.13	
A3X01	04/15/92	08:35	0.16	2661.358	7.945	0.020	58.29	
A3X01	04/22/92	09:55	0.15	2668.413	7.055	0.021	58.44	
A3X01	05/06/92	10:29	0.27	2682.437	14.024	0.019	58.71	
A3X01	05/13/92	13:15	0.17	2689.552	7.115	0.024	58.88	
A3X01	05/21/92	10:57	0.15	2697.456	7.904	0.019	59.03	
A3X01	05/27/92	09:40	0.12	2703.403	5.947	0.020	59.15	
A3X01	06/09/92	09:50	0.25	2716.410	13.007	0.019	59.40	
A3X01	06/18/92	08:45	0.19	2725.365	8.955	0.021	59.59	
A3X01	06/25/92	10:15	0.14	2732.427	7.062	0.020	59.73	
A3X01	07/01/92	09:04	0.12	2738.378	5.951	0.020	59.85	
A3X01	07/08/92	09:50	0.14	2745.410	7.032	0.020	59.99	
A3X01	07/15/92	09:01	0.15	2752.376	6.966	0.022	60.14	
A3X01	07/22/92	10:15	0.14	2759.427	7.051	0.020	60.28	
A3X01	07/29/92	10:15	0.14	2766.427	7.000	0.020	60.42	
A3X01	08/04/92	09:11	0.14	2772.383	5.956	0.024	60.56	
A3X01	08/18/92	09:30	0.25	2786.396	14.013	0.018	60.81	
A3X01	09/02/92	09:30	0.30	2801.396	15.000	0.020	61.11	

TABLE A-2 (Continued)
BRINE ACCUMULATION DATA TABLE
 Data through December 31, 1993

LOCATION	DATE	TIME	LITERS REMOVED	DAYS	DAYS	LITERS PER DAY	CUMULATIVE	REMARKS
				SINCE 1/1/85	USED FOR CALCULATION		LITERS COLLECTED	
A3X01	09/09/92	09:30	0.15	2808.396	7.000	0.021	61.26	
A3X01	09/17/92	09:55	0.15	2816.413	8.017	0.019	61.41	
A3X01	09/23/92	09:45	0.14	2822.406	5.993	0.023	61.55	
A3X01	09/30/92	10:20	0.13	2829.431	7.025	0.019	61.68	
A3X01	10/12/92	12:59	0.25	2841.541	12.110	0.021	61.93	
A3X01	10/21/92	12:31	0.16	2850.522	8.981	0.018	62.09	
A3X01	10/28/92	08:45	0.14	2857.365	6.843	0.020	62.23	
A3X01	11/11/92	10:45	0.26	2871.448	14.083	0.018	62.49	
A3X01	11/18/92	12:50	0.15	2878.535	7.087	0.021	62.64	
A3X01	11/25/92	10:00	0.05	2885.417	6.882	0.007	62.69	
A3X01	12/09/92	13:20	0.36	2899.556	14.139	0.025	63.05	
A3X01	12/16/92	09:45	0.14	2906.406	6.850	0.020	63.19	
A3X01	01/07/93	09:20	0.37	2928.389	21.983	0.017	63.56	
A3X01	01/13/93	09:20	0.15	2934.389	6.000	0.025	63.71	
A3X01	01/28/93	09:46	0.29	2949.407	15.018	0.019	64.00	
A3X01	02/11/93	09:20	0.00	2963.389	0.000	0.000	64.00	No suction.
A3X01	02/26/93		0.00	2978.000	0.000	0.000	64.00	No vacuum.
A3X01	03/19/93	10:35	0.15	2999.441	0.000	0.000	64.15	Partial evacuation.
A3X01	03/25/93	09:30	0.13	3005.396	55.989	0.005	64.28	Combine with 0.15 liters from 03-19-93.
A3X01	03/31/93	12:10	0.14	3011.507	6.111	0.023	64.42	
A3X01	06/16/93	09:45	0.34	3088.406	76.899	0.004	64.76	Last time sampled.
<hr/>								
BX01	06/02/84	00:00	NA	0.000	0.000	0.000	0.00	Room B completed.
BX01	01/27/85	00:00	NA	26.000	0.000	0.000	0.00	Downhole drilled 1/24/85 to 1/27/85. Wet core and brine encountered 1/26/85 at 35 to 36.5 feet.
BX01	02/05/85	11:00	00.39	35.458	248.458	0.002	0.39	First time collected.
BX01	02/11/85	12:00	00.72	41.500	6.042	0.119	1.11	
BX01	02/19/85	13:00	00.70	49.542	8.042	0.087	1.81	
BX01	02/26/85	12:45	00.61	56.531	6.989	0.087	2.42	
BX01	03/07/85	09:15	00.70	65.385	8.854	0.079	3.12	
BX01	03/12/85	11:45	00.41	70.490	5.105	0.080	3.53	
BX01	03/20/85	12:50	00.61	78.535	8.045	0.076	4.14	
BX01	03/26/85	10:45	00.45	84.448	5.913	0.076	4.59	
BX01	04/02/85	11:44	00.51	91.489	7.041	0.072	5.10	
BX01	04/10/85	11:38	00.55	99.485	7.996	0.069	5.65	
BX01	04/17/85	11:00	00.45	106.458	6.973	0.065	6.10	
BX01	04/23/85	10:05	00.38	112.420	5.962	0.064	6.48	Room B heaters turned on 4/23/85.
BX01	05/01/85	11:40	00.46	120.486	8.066	0.057	6.94	
BX01	06/04/85	09:30	02.00	154.396	33.910	0.059	8.94	First check in several weeks.
BX01	07/16/85	10:15	02.34	196.427	42.031	0.056	11.28	Brine effervesces.
BX01	08/26/85	13:56	02.38	237.581	41.154	0.058	13.66	Room temperature 98 degrees F at collar, 103 F in center of room.
BX01	10/08/85	12:00	02.27	280.500	42.919	0.053	15.93	
BX01	11/21/85	10:05	02.42	324.420	43.920	0.055	18.35	
BX01	12/04/85	13:35	00.69	337.566	13.146	0.052	19.04	Collected for chemistry, sample #8.

TABLE A-2 (Continued)
BRINE ACCUMULATION DATA TABLE
 Data through December 31, 1993

LOCATION	DATE	TIME	LITERS REMOVED	DAYS SINCE 1/1/85	DAYS USED FOR CALCULATION	LITERS PER DAY	CUMULATIVE LITERS COLLECTED	REMARKS
BX01	01/31/86	10:25	02.95	395.434	57.868	0.051	21.99	
BX01	02/12/86	09:30	00.80	407.396	11.962	0.067	22.79	
BX01	04/16/86	11:00	03.45	470.458	63.062	0.055	26.24	
BX01	04/30/86	09:45	00.73	484.406	13.948	0.052	26.97	
BX01	05/06/86	09:18	00.30	490.388	5.982	0.050	27.27	
BX01	06/10/86	10:20	01.85	525.431	35.043	0.053	29.12	Collected for chemistry, sample #12.
BX01	08/19/86	10:50	03.21	595.451	70.020	0.046	32.33	
BX01	09/09/86	11:00	01.30	616.458	21.007	0.062	33.63	
BX01	10/01/86	11:08	01.16	638.464	22.006	0.053	34.79	
BX01	11/05/86	10:00	NA	673.417	0.000	0.000	34.79	Not collected.
BX01	11/20/86	10:39	02.40	688.444	49.980	0.048	37.19	
BX01	12/30/86	14:10	01.75	728.590	40.146	0.044	38.94	
BX01	02/03/87	11:00	01.67	763.458	34.868	0.048	40.61	
BX01	03/06/87	11:50	NA	794.493	0.000	0.000	40.61	Room closed, bad back, not sampled.
BX01	10/20/87			1022.000	0.000	0.000	40.61	Room closed, could not sample. No calculation.
BX01	11/16/87	11:10	12.86	1049.465	286.007	0.045	53.47	Collected for chemistry, sample #198A, #201A, #204A, #207A, #210A #198B, #201B, #204B, #207B, & #210B.
BX01	01/04/88			1098.000	0.000	0.000	53.47	Could not sample. Room closed.
BX01	02/08/88	12:35	3.71	1133.524	84.059	0.044	57.18	Collected for chemistry, sample #287, #288, #289, #290, #291, #292 #293 & #294.
BX01	03/29/88	12:00	2.30	1183.500	49.976	0.046	59.48	Collected for chemistry, sample #379 - #383.
BX01	05/12/88	10:44	1.67	1227.447	43.947	0.038	61.15	Sampled for SNL PA.
BX01	07/12/88	09:50	2.23	1288.410	60.963	0.037	63.38	Collected for chemistry, sample #449 - #452.
BX01	09/27/88	08:00	2.61	1365.333	76.923	0.034	65.99	Collected for chemistry, sample #504 - #509.
BX01	12/13/88	09:00	0	1442.375	0.000	0.000	65.99	Could not sample. Room locked.
BX01	01/30/89	NA	NA	1490.000	0.000	0.000	65.99	Heaters in Room B turned off at 14:20 on 1/30/89.
BX01	03/14/89	08:40	6.17	1533.361	168.028	0.037	72.16	Collected for chemistry, sample #646 - 651.
BX01	04/06/89	11:53	NA	1556.495	0.000	0.000	72.16	Room locked.
BX01	04/20/89	10:00	NA	1570.417	0.000	0.000	72.16	Room locked.
BX01	05/17/89	11:00	2.90	1597.458	64.097	0.045	75.06	Sample saved for chemistry, sample #759 - 761 A & B.
BX01	07/11/89	09:30	1.77	1652.396	54.938	0.032	76.83	
BX01	09/12/89	10:50	1.90	1715.451	63.055	0.030	78.73	Increased buildup of salt crust on cap. No indication of leakage into hole, walls dry.
BX01	10/11/89	10:30	NA	1744.438	0.000	0.000	78.73	Installed collection device. Collection point for brine located outside heated room.
BX01	10/20/89	10:30	0.61	1753.438	37.987	0.016	79.34	Sample saved for chemistry, sample #848.
BX01	11/10/89	08:50	0.65	1774.368	20.930	0.031	79.99	Sample saved for chemistry, sample #858-1,2.
BX01	11/29/89	10:50	0.66	1793.451	19.083	0.035	80.65	Sample saved for chemistry, sample #869.

TABLE A-2 (Continued)
BRINE ACCUMULATION DATA TABLE
 Data through December 31, 1993

LOCATION	DATE	TIME	LITERS REMOVED	DAYS	DAYS	LITERS PER DAY	CUMULATIVE	REMARKS
				SINCE 1/1/85	USED FOR CALCULATION		LITERS COLLECTED	
BX01	12/12/89	08:49	0.63	1806.367	12.916	0.049	81.28	Sample saved for chemistry, sample #880.
BX01	01/04/90	09:03	0.14	1829.377	23.010	0.006	81.42	
BX01	01/17/90	10:10	0.17	1842.424	13.047	0.013	81.59	
BX01	01/31/90	08:57	0.20	1856.373	13.949	0.014	81.79	
BX01	02/13/90	10:23	0.41	1869.433	13.060	0.031	82.20	
BX01	02/27/90	11:12	0.61	1883.467	14.034	0.043	82.81	
BX01	03/05/90	10:24	0.35	1889.433	5.966	0.059	83.16	
BX01	03/21/90	10:59	0.58	1905.458	16.025	0.036	83.74	
BX01	04/04/90	10:26	0.60	1919.435	13.977	0.043	84.34	
BX01	04/17/90	10:47	0.71	1932.449	0.000	0.000	85.05	
BX01	04/24/90	09:45	0.63	1939.406	0.000	0.000	85.68	
BX01	04/25/90	09:00	0.76	1940.375	20.940	0.100	86.44	Combined with 0.71 liters from 04/17/90 and 0.63 liters from 04/24/90. Used 2.1 liters for calculation.
BX01	05/02/90	10:59	0.67	1947.458	7.083	0.095	87.11	
BX01	05/09/90	10:39	0.19	1954.444	6.986	0.027	87.30	
BX01	05/16/90	09:56	0.20	1961.414	6.970	0.029	87.50	
BX01	05/23/90	12:55	0.03	1968.538	7.124	0.004	87.53	
BX01	05/31/90	11:11	0.13	1976.466	7.928	0.016	87.66	
BX01	06/01/90	10:15	NA	1977.427	0.000	0.000	87.66	Replaced sampler.
BX01	06/06/90	10:53	0.41	1982.453	5.987	0.068	88.07	
BX01	06/14/90	09:14	0.28	1990.385	7.932	0.035	88.35	
BX01	06/20/90	08:42	0.05	1996.363	5.978	0.008	88.40	
BX01	06/28/90	09:35	0.40	2004.399	8.036	0.050	88.80	
BX01	07/17/90	10:20	0.12	2023.431	0.000	0.000	88.92	Partial evacuation.
BX01	07/18/90	09:54	0.47	2024.413	20.014	0.029	89.39	Combined with 0.12 liters from 07/17/90. Used 0.59 liters for calculation.
BX01	07/25/90	08:10	0.38	2031.340	6.927	0.055	89.77	
BX01	08/07/90	11:40	0.40	2044.486	13.146	0.030	90.17	
BX01	08/16/90	10:52	0.31	2053.453	8.967	0.035	90.48	
BX01	08/22/90	11:40	0.21	2059.486	6.033	0.035	90.69	
BX01	08/29/90	12:27	0.09	2066.519	7.033	0.013	90.78	
BX01	09/05/90	11:10	0.12	2073.465	6.946	0.017	90.90	
BX01	09/13/90	09:27	0.30	2081.394	7.929	0.038	91.20	
BX01	09/25/90	12:51	0.48	2093.535	0.000	0.000	91.68	Brine probably left in hole.
BX01	09/26/90	11:18	0.02	2094.471	13.077	0.038	91.70	Combined with 0.48 liters from 09/25/90. Used 0.50 liters for calculation.
BX01	10/03/90	09:25	0.21	2101.392	6.921	0.030	91.91	
BX01	10/10/90	11:10	0.23	2108.465	7.073	0.033	92.14	
BX01	10/18/90	10:46	0.23	2116.449	7.984	0.029	92.37	
BX01	10/24/90	12:02	0.20	2122.501	6.052	0.033	92.57	
BX01	10/31/90	11:26	0.22	2129.476	6.975	0.032	92.79	
BX01	11/07/90	10:49	0.15	2136.451	6.975	0.022	92.94	
BX01	11/14/90	12:01	0.26	2143.501	7.050	0.037	93.20	
BX01	11/28/90	10:41	0.49	2157.445	13.944	0.035	93.69	
BX01	12/05/90	08:53	0.21	2164.370	6.925	0.030	93.90	
BX01	12/13/90	09:30	0.10	2172.396	8.026	0.012	94.00	

TABLE A-2 (Continued)
BRINE ACCUMULATION DATA TABLE
 Data through December 31, 1993

LOCATION	DATE	TIME	LITERS REMOVED	DAYS	DAYS	LITERS PER DAY	CUMULATIVE	REMARKS
				SINCE 1/1/85	USED FOR CALCULATION		LITERS COLLECTED	
BX01	12/20/90	08:47	0.38	2179.366	6.970	0.055	94.38	
BX01	01/09/91	09:00	0.30	2199.375	20.009	0.015	94.68	
BX01	01/16/91	09:00	0.45	2206.375	7.000	0.064	95.13	
BX01	01/23/91	10:00	0.29	2213.417	7.042	0.041	95.42	
BX01	01/30/91	09:45	0.20	2220.406	6.989	0.029	95.62	
BX01	02/13/91	11:05	0.43	2234.462	14.056	0.031	96.05	
BX01	02/20/91	10:32	0.21	2241.439	6.977	0.030	96.26	
BX01	02/27/91	10:12	0.12	2248.425	6.986	0.017	96.38	
BX01	03/07/91	10:00	0.27	2256.417	7.992	0.034	96.65	
BX01	03/20/91	11:09	0.38	2269.465	13.048	0.029	97.03	
BX01	03/28/91	10:57	0.19	2277.456	7.991	0.024	97.22	
BX01	04/10/91	09:07	0.43	2290.380	12.924	0.033	97.65	
BX01	05/14/91	09:30	0.45	2324.396	0.000	0.000	98.10	Partial evacuation.
BX01	05/15/91	09:52	0.61	2325.411	35.031	0.030	98.71	Combined with 0.45 liters from 05/14/91.
BX01	05/30/91	11:30	0.67	2340.479	15.068	0.044	99.38	
BX01	06/05/91	14:00	0.20	2346.583	6.104	0.033	99.58	
BX01	06/12/91	10:30	0.20	2353.438	6.855	0.029	99.78	
BX01	06/19/91	14:48	0.21	2360.617	7.179	0.029	99.99	
BX01	06/26/91	09:33	0.20	2367.398	6.781	0.029	100.19	
BX01	07/11/91	10:28	0.46	2382.436	15.038	0.031	100.65	
BX01	07/17/91	09:55	0.18	2388.413	5.977	0.030	100.83	
BX01	07/30/91	09:45	0.43	2401.406	0.000	0.000	101.26	Partial evacuation.
BX01	07/31/91	09:43	0.06	2402.405	13.992	0.035	101.32	Combined with 0.43 liters from 07/30/91.
BX01	08/08/91	08:21	0.26	2410.348	7.943	0.033	101.58	
BX01	08/14/91	09:15	0.18	2416.385	6.037	0.030	101.76	
BX01	08/21/91	09:16	0.20	2423.386	7.001	0.029	101.96	
BX01	08/28/91	09:10	0.22	2430.382	6.996	0.031	102.18	
BX01	09/04/91	10:18	0.39	2437.429	7.047	0.055	102.57	
BX01	09/11/91	11:06	0.22	2444.463	7.034	0.031	102.79	
BX01	10/02/91	10:15	0.48	2465.427	20.964	0.023	103.27	
BX01	10/16/91	10:00	0.52	2479.417	13.990	0.037	103.79	
BX01	10/31/91	11:00	0.44	2494.458	15.041	0.029	104.23	
BX01	11/06/91	11:13	0.22	2500.467	6.009	0.037	104.45	
BX01	11/13/91	10:00	0.22	2507.417	6.950	0.032	104.67	
BX01	11/20/91	9:38	0.20	2514.381	6.964	0.029	104.87	
BX01	11/27/91	08:45	0.21	2521.365	6.984	0.030	105.08	
BX01	12/04/91	10:05	0.23	2528.420	7.055	0.033	105.31	
BX01	12/11/91	10:10	0.20	2535.424	7.004	0.029	105.51	
BX01	12/23/91	09:00	0.15	2547.375	11.951	0.013	105.66	
BX01	01/08/92	09:00	0.45	2563.375	16.000	0.028	106.11	
BX01	01/15/92	09:30	0.24	2570.396	7.021	0.034	106.35	
BX01	01/22/92	09:35	0.24	2577.399	7.003	0.034	106.59	
BX01	01/29/92	10:14	0.20	2584.426	7.027	0.028	106.79	
BX01	02/12/92	09:10	0.40	2598.382	13.956	0.029	107.19	
BX01	02/19/92	09:35	0.20	2605.399	7.017	0.029	107.39	
BX01	02/26/92	08:35	0.21	2612.358	6.959	0.030	107.60	
BX01	03/11/92	08:45	0.40	2626.365	14.007	0.029	108.00	

TABLE A-2 (Continued)
BRINE ACCUMULATION DATA TABLE
 Data through December 31, 1993

LOCATION	DATE	TIME	LITERS REMOVED	DAYS	DAYS	LITERS PER DAY	CUMULATIVE	REMARKS
				SINCE 1/1/85	USED FOR CALCULATION		LITERS COLLECTED	
BX01	03/18/92	08:35	0.22	2633.358	6.993	0.031	108.22	
BX01	03/25/92	09:45	0.20	2640.406	7.048	0.028	108.42	
BX01	04/01/92	09:45	0.20	2647.406	7.000	0.029	108.62	
BX01	04/07/92	09:50	0.17	2653.410	6.004	0.028	108.79	
BX01	04/15/92	08:30	0.23	2661.354	7.944	0.029	109.02	
BX01	04/22/92	09:53	0.20	2668.412	7.058	0.028	109.22	
BX01	05/06/92	10:43	0.09	2682.447	0.000	0.000	109.31	Partial evacuation. No vacuum.
BX01	05/07/92	09:45	0.33	2683.406	14.994	0.028	109.64	Combined with 0.09 liters removed 05/06/92 for total volume.
BX01	05/13/92	13:18	0.19	2689.554	6.148	0.031	109.83	
BX01	05/21/92	10:52	0.34	2697.453	7.899	0.043	110.17	
BX01	05/27/92	09:32	0.18	2703.397	5.944	0.030	110.35	
BX01	06/09/92	09:40	0.36	2716.403	13.006	0.028	110.71	
BX01	06/18/92	09:10	0.28	2725.382	8.979	0.031	110.99	
BX01	06/25/92	10:07	0.21	2732.422	7.040	0.030	111.20	
BX01	07/01/92	08:59	0.16	2738.374	5.952	0.027	111.36	
BX01	07/08/92	09:55	0.20	2745.413	7.039	0.028	111.56	
BX01	07/15/92	08:50	0.21	2752.368	6.955	0.030	111.77	
BX01	07/22/92	10:00	0.19	2759.417	7.049	0.027	111.96	
BX01	07/29/92	10:12	0.21	2766.425	7.008	0.030	112.17	
BX01	08/04/92	09:20	0.17	2772.389	5.964	0.029	112.34	
BX01	08/18/92	09:25	0.40	2786.392	14.003	0.029	112.74	
BX01	09/02/92	09:24	0.40	2801.392	15.000	0.027	113.14	
BX01	09/09/92	09:20	0.23	2808.389	6.997	0.033	113.37	
BX01	09/17/92	09:45	0.23	2816.406	8.017	0.029	113.60	
BX01	09/23/92	09:30	0.17	2822.396	5.990	0.028	113.77	
BX01	09/30/92	10:13	0.21	2829.426	7.030	0.030	113.98	
BX01	10/12/92	12:55	0.36	2841.538	12.112	0.030	114.34	
BX01	10/21/92	12:30	0.05	2850.521	8.983	0.006	114.39	
BX01	10/28/92	08:55	0.38	2857.372	6.851	0.055	114.77	
BX01	11/11/92	10:35	0.20	2871.441	14.069	0.014	114.97	
BX01	11/18/92	12:45	0.15	2878.531	7.090	0.021	115.12	
BX01	11/25/92	09:55	0.20	2885.413	6.882	0.029	115.32	
BX01	12/09/92	13:10	0.14	2899.549	14.136	0.010	115.46	
BX01	12/16/92	09:40	0.20	2906.403	6.854	0.029	115.66	
BX01	01/07/93	09:10	0.23	2928.382	21.979	0.010	115.89	
BX01	01/13/93	08:44	0.26	2934.364	5.982	0.043	116.15	
BX01	01/28/93	09:44	0.25	2949.406	15.042	0.017	116.40	
BX01	02/11/93	09:25	0.27	2963.392	13.986	0.019	116.67	
BX01	02/26/93	08:00	0.30	2978.333	14.941	0.020	116.97	
BX01	03/19/93	10:30	0.52	2999.438	21.105	0.025	117.49	
BX01	03/25/93	09:15	0.57	3005.385	5.947	0.096	118.06	
BX01	04/28/93	10:35	0.24	3039.441	34.056	0.007	118.30	Last time sampled.
BX01	08/19/93			3152.000	0.000	0.000	118.30	Collecting hose plugged; unable to open.
DH36	11/21/84	00:00	NA	-41.000	112.559	0.000	0.00	Approximate date this part of Room G

TABLE A-2 (Continued)
BRINE ACCUMULATION DATA TABLE
 Data through December 31, 1993

LOCATION	DATE	TIME	LITERS REMOVED	DAYS SINCE 1/1/85	DAYS USED FOR CALCULATION	LITERS PER DAY	CUMULATIVE LITERS COLLECTED	REMARKS
								excavated.
DH36	01/26/85	00:00	NA	25.000	66.000	0.000	0.00	Downhole drilled 1/26/85.
DH36	01/28/85	09:00	NA	27.375	0.000	0.000	0.00	Moist muck at the bottom.
DH36	02/05/85	11:15	02.50	35.469	10.469	0.239	2.50	About 1 ft. muck, brine and hydraulic fluid. First time bailed.
DH36	02/11/85	11:00	01.51	41.458	5.989	0.252	4.01	Brine, muck, hydraulic fluid.
DH36	02/19/85	12:10	01.78	49.507	8.049	0.221	5.79	Some muck.
DH36	02/26/85	10:45	01.48	56.448	6.941	0.213	7.27	Brine and muck.
DH36	03/05/85	10:00	01.76	63.417	6.969	0.253	9.03	
DH36	03/12/85	10:00	01.55	70.417	7.000	0.221	10.58	
DH36	03/20/85	10:26	01.59	78.435	8.018	0.198	12.17	
DH36	03/26/85	09:45	01.35	84.406	5.971	0.226	13.52	
DH36	04/02/85	10:15	01.58	91.427	7.021	0.225	15.10	
DH36	04/10/85	10:25	01.71	99.434	8.007	0.214	16.81	
DH36	04/17/85	13:30	01.49	106.563	7.129	0.209	18.30	
DH36	04/23/85	11:46	01.45	112.490	5.927	0.245	19.75	
DH36	04/30/85	11:21	01.49	119.473	6.983	0.213	21.24	
DH36	05/07/85	09:58	01.55	126.415	6.942	0.223	22.79	
DH36	05/14/85	10:54	01.77	133.454	7.039	0.251	24.56	
DH36	05/21/85	10:45	01.61	140.448	6.994	0.230	26.17	
DH36	05/29/85	10:00	01.50	148.417	7.969	0.188	27.67	
DH36	06/04/85	11:33	01.40	154.481	6.064	0.231	29.07	
DH36	06/11/85	11:15	01.55	161.469	6.988	0.222	30.62	
DH36	06/18/85	10:17	01.58	168.428	6.959	0.227	32.20	
DH36	06/25/85	10:40	01.43	175.444	7.016	0.204	33.63	
DH36	07/02/85	11:00	01.59	182.458	7.014	0.227	35.22	
DH36	07/09/85	11:15	01.54	189.469	7.011	0.220	36.76	
DH36	07/16/85	11:50	01.58	196.493	7.024	0.225	38.34	Brine effervesces.
DH36	07/24/85	10:46	01.78	204.449	7.956	0.224	40.12	
DH36	07/30/85	10:20	01.39	210.431	5.982	0.232	41.51	
DH36	08/06/85	10:43	01.70	217.447	7.016	0.242	43.21	
DH36	08/14/85	11:02	01.58	225.460	8.013	0.197	44.79	Valve leaked, some brine drained back down hole.
DH36	08/20/85	11:11	01.42	231.466	6.006	0.236	46.21	
DH36	08/28/85	10:00	01.94	239.417	7.951	0.244	48.15	
DH36	09/04/85	10:32	01.69	246.439	7.022	0.241	49.84	
DH36	09/10/85	10:35	01.41	252.441	6.002	0.235	51.25	
DH36	09/17/85	09:42	01.53	259.404	6.963	0.220	52.78	
DH36	09/24/85	09:50	01.53	266.410	7.006	0.218	54.31	
DH36	10/01/85	09:55	01.58	273.413	7.003	0.226	55.89	
DH36	10/08/85	10:52	01.63	280.453	7.040	0.232	57.52	
DH36	10/15/85	10:30	01.58	287.438	6.985	0.226	59.10	
DH36	10/23/85	10:23	01.82	295.433	7.995	0.228	60.92	
DH36	10/29/85	09:51	01.36	301.410	5.977	0.228	62.28	
DH36	11/05/85	09:27	01.63	308.394	6.984	0.233	63.91	
DH36	11/13/85	10:14	01.79	316.426	8.032	0.223	65.70	
DH36	11/21/85	11:36	01.91	324.483	8.057	0.237	67.61	

TABLE A-2 (Continued)
BRINE ACCUMULATION DATA TABLE
 Data through December 31, 1993

LOCATION	DATE	TIME	LITERS REMOVED	DAYS	DAYS	LITERS PER DAY	CUMULATIVE	REMARKS
				SINCE 1/1/85	USED FOR CALCULATION		LITERS COLLECTED	
DH36	11/26/85	11:30	01.01	329.479	4.996	0.202	68.62	
DH36	12/03/85	13:35	01.50	336.566	7.087	0.212	70.12	.50 liters for chemical analysis, sample #4.
DH36	12/10/85	12:15	01.52	343.510	6.944	0.219	71.64	
DH36	01/23/86	11:00	09.30	387.458	43.948	0.212	80.94	Entry restricted since 12/10/85 due to mining activities.
DH36	01/31/86	12:20	01.38	395.514	8.056	0.171	82.32	
DH36	02/12/86	11:00	03.02	407.458	11.944	0.253	85.34	
DH36	02/19/86	11:45	01.55	414.490	7.032	0.220	86.89	
DH36	02/28/86	13:20	01.85	423.556	9.066	0.204	88.74	
DH36	03/06/86	10:45	01.30	429.448	5.892	0.221	90.04	Volume was estimated.
DH36	03/13/86	10:10	01.50	436.424	6.976	0.215	91.54	
DH36	03/26/86	10:20	02.56	449.431	13.007	0.197	94.10	
DH36	04/02/86	09:40	01.75	456.403	6.972	0.251	95.85	
DH36	04/08/86	09:45	00.97	462.406	6.003	0.162	96.82	
DH36	04/16/86	12:25	01.65	470.517	8.111	0.203	98.47	
DH36	04/24/86	10:20	02.00	478.431	7.914	0.253	100.47	
DH36	04/30/86	10:55	01.21	484.455	6.024	0.201	101.68	
DH36	05/06/86	10:14	01.20	490.426	5.971	0.201	102.88	
DH36	05/13/86	11:13	01.42	497.467	7.041	0.202	104.30	
DH36	05/20/86	11:10	01.50	504.465	6.998	0.214	105.80	
DH36	05/27/86	15:45	01.40	511.656	7.191	0.195	107.20	
DH36	06/03/86	10:10	01.38	518.424	6.768	0.204	108.58	
DH36	06/10/86	11:35	01.24	525.483	7.059	0.176	109.82	Valve leaked, some brine drained back down hole.
DH36	06/17/86	11:00	01.65	532.458	6.975	0.237	111.47	Sample for brine chemistry, #24.
DH36	06/24/86	11:00	01.45	539.458	7.000	0.207	112.92	
DH36	07/01/86	14:05	01.55	546.587	7.129	0.217	114.47	
DH36	07/08/86	10:45	01.40	553.448	6.861	0.204	115.87	
DH36	07/16/86	10:45	01.76	561.448	8.000	0.220	117.63	
DH36	07/22/86	10:07	01.29	567.422	5.974	0.216	118.92	
DH36	07/29/86	10:40	01.45	574.444	7.022	0.206	120.37	
DH36	08/05/86	11:20	01.46	581.472	7.028	0.208	121.83	
DH36	08/12/86	10:37	01.50	588.442	6.970	0.215	123.33	
DH36	08/19/86	11:35	01.38	595.483	7.041	0.196	124.71	
DH36	08/26/86	10:38	01.49	602.443	6.960	0.214	126.20	Static level not measured.
DH36	09/04/86	10:41	01.70	611.445	9.002	0.189	127.90	
DH36	09/09/86	10:15	01.20	616.427	4.982	0.241	129.10	Sample #26.
DH36	09/16/86	10:20	01.37	623.431	7.004	0.196	130.47	
DH36	09/23/86	10:18	01.40	630.429	6.998	0.200	131.87	
DH36	10/01/86	12:18	01.76	638.513	8.084	0.218	133.63	
DH36	10/08/86	11:10	01.44	645.465	6.952	0.207	135.07	Brine effervesces as it is poured into beaker.
DH36	10/14/86	11:57	01.21	651.498	6.033	0.201	136.28	Static level not measured.
DH36	11/05/86	11:38	4.28	673.485	21.987	0.195	140.56	
DH36	11/20/86	12:35	03.12	688.524	15.039	0.207	143.68	
DH36	12/30/86	12:25	01.72	728.517	0.000	0.000	145.40	Partial evacuation. No calculation. Do not

TABLE A-2 (Continued)
BRINE ACCUMULATION DATA TABLE
 Data through December 31, 1993

LOCATION	DATE	TIME	LITERS REMOVED	DAYS SINCE 1/1/85	DAYS USED FOR CALCULATION	LITERS PER DAY	CUMULATIVE LITERS COLLECTED	REMARKS
DH36	12/31/86	12:38	6.54	729.526	41.002	0.201	151.94	plot or use zero value. Calculated using 8.26 liters in 41.002 days (1.72 liters 12/30/86 plus 6.54 liters 12/31/86).
DH36	02/03/87	13:35	06.84	763.566	34.040	0.201	158.78	
DH36	03/06/87	11:20	5.84	794.472	30.906	0.189	164.62	
DH36	03/30/87	11:27	4.95	818.477	24.005	0.206	169.57	
DH36	05/07/87	11:33	6.62	856.481	38.004	0.174	176.19	
DH36	06/17/87	10:45	7.25	897.448	0.000	0.000	183.44	Sample for chem. #108A, #108B, #114A, #114B, #121A, #121B, #127A, #127B, #134A, #134B. Some brine left in hole, no calculation.
DH36	06/18/87	12:10	0.49	898.507	42.026	0.184	183.93	Original l/day calculation too high due to residual brine left in hole. Recalculated using 7.74 l (7.25 l 6/17/87 plus 0.49 l 6/18/87).
DH36	07/28/87	11:27	7.76	938.477	39.970	0.194	191.69	
DH36	09/01/87	10:50	6.99	973.451	34.974	0.200	198.68	Collected for chemistry, sample #153 A&B, #160 A&B, #163 A&B, #158 A&B, #155 A&B, #167 A&B.
DH36	10/20/87	11:56	8.58	1022.497	49.046	0.175	207.26	
DH36	11/19/87	11:30	4.19	1052.479	29.982	0.140	211.45	Collected for chemistry, sample #199, #205, #208, & #211.
DH36	01/04/88	11:50	6.74	1098.493	46.014	0.146	218.19	
DH36	02/08/88	11:50	4.90	1133.493	35.000	0.140	223.09	Collected for chemistry, sample #261, #262, #263, #264, #265, #266, #267, #268, #269 & #270.
DH36	03/29/88	11:35	7.25	1183.483	49.990	0.145	230.34	Collected for chemistry, sample #367 - #378.
DH36	05/05/88	09:45	5.01	1220.406	36.923	0.136	235.35	Sampled for SNL PA.
DH36	05/12/88	09:50	1.30	1227.410	7.004	0.186	236.65	Sampled for SNL PA.
DH36	07/12/88	08:50	7.90	1288.368	60.958	0.130	244.55	Collected for chemistry, sample #422 - #436.
DH36	07/28/88	10:25	1.50	1304.434	16.066	0.093	246.05	Sampled for SNL PA.
DH36	08/11/88	10:30	3.66	1318.438	14.004	0.261	249.71	Sampled for SNL PA.
DH36	08/25/88	09:24	2.05	1332.392	13.954	0.147	251.76	Sampled for SNL PA.
DH36	09/08/88	14:50		1346.618	0.000	0.000	251.76	Did not sample.
DH36	09/14/88	08:40	2.36	1352.361	19.969	0.118	254.12	Slight orange color.
DH36	09/27/88	10:45	1.30	1365.448	13.087	0.099	255.42	Collected for chemistry, sample #537 - #539.
DH36	12/13/88	10:00	10.63	1442.417	76.969	0.138	266.05	Collected for chemistry, sample #570 - #581.
DH36	03/14/89	10:10	11.16	1533.424	91.007	0.123	277.21	Sample saved for chemistry, sample #684 - 695.
DH36	04/06/89	09:31	2.73	1556.397	22.973	0.119	279.94	2.5 liters saved for SNL brine study.
DH36	04/20/89	09:40	1.79	1570.403	14.006	0.128	281.73	Sample saved for SNL/NM brine study.
DH36	05/17/89	10:20	6.45	1597.431	27.028	0.239	288.18	Sample saved for SNL/NM brine study.

TABLE A-2 (Continued)
BRINE ACCUMULATION DATA TABLE
 Data through December 31, 1993

LOCATION	DATE	TIME	LITERS REMOVED	DAYS	DAYS	LITERS PER DAY	CUMULATIVE	REMARKS
				SINCE 1/1/85	USED FOR CALCULATION		LITERS COLLECTED	
DH36	06/06/89	10:10	2.62	1617.424	19.993	0.131	290.80	Sample saved for chemistry.
DH36	06/29/89	10:35	2.42	1640.441	23.017	0.105	293.22	Sample saved for SNL/NM brine study.
DH36	07/06/89	09:10	1.08	1647.382	6.941	0.156	294.30	
DH36	07/25/89	09:55	2.35	1666.413	19.031	0.123	296.65	Sample saved for SNL/NM brine study.
DH36	08/16/89	09:27	2.75	1688.394	21.981	0.125	299.40	Sample saved for SNL/NM brine study.
DH36	09/12/89	09:30	3.81	1715.396	27.002	0.141	303.21	Sample saved for chemistry.
DH36	12/13/89	11:10	11.07	1807.465	92.069	0.120	314.28	Sample saved for chemistry, sample #900.
DH36	01/10/90	10:18	2.48	1835.429	27.964	0.089	316.76	
DH36	01/24/90	09:37	2.0	1849.401	13.972	0.143	318.76	
DH36	02/07/90	10:17	1.53	1863.428	14.027	0.109	320.29	
DH36	02/21/90	09:50	1.75	1877.410	13.982	0.125	322.04	
DH36	03/05/90	09:25	1.10	1889.392	11.982	0.092	323.14	
DH36	03/14/90	12:30	NA	1898.521	0.000	0.000	323.14	Installed sampler.
DH36	03/19/90	10:36	0.80	1903.442	0.000	0.000	323.94	Brine probably left in hole.
DH36	03/21/90	10:16	0.57	1905.428	16.036	0.085	324.51	Combined with 0.80 liters from 03/19/90. Used 1.37 liters for calculation.
DH36	04/04/90	09:09	1.08	1919.381	13.953	0.077	325.59	
DH36	04/10/90	08:34	0.97	1925.357	5.976	0.162	326.56	
DH36	04/17/90	10:17	0.85	1932.428	7.071	0.120	327.41	
DH36	04/24/90	09:14	0.86	1939.385	0.000	0.000	328.27	
DH36	04/25/90	08:45	0.57	1940.365	7.937	0.180	328.84	Combined with 0.86 liters from 04/27/90. Used 1.43 liters for calculation.
DH36	05/02/90	10:24	1.37	1947.433	7.068	0.194	330.21	
DH36	05/09/90	08:35	0.68	1954.358	6.925	0.098	330.89	
DH36	05/16/90	08:45	0.78	1961.365	7.007	0.111	331.67	
DH36	05/17/90	07:50	0.17	1962.326	0.961	0.177	331.84	
DH36	05/23/90	12:02	0.68	1968.501	6.175	0.110	332.52	
DH36	05/31/90	08:38	0.85	1976.360	7.859	0.108	333.37	
DH36	06/01/90	11:00	0.15	1977.458	1.098	0.137	333.52	Repaired sampler, evacuated hole.
DH36	06/06/90	08:47	0.45	1982.366	4.908	0.092	333.97	
DH36	06/14/90	08:38	0.82	1990.360	7.994	0.103	334.79	
DH36	06/20/90	09:53	0.59	1996.412	6.052	0.097	335.38	
DH36	06/28/90	08:38	0.88	2004.360	7.948	0.111	336.26	
DH36	07/17/90	10:52	0.41	2023.453	0.000	0.000	336.67	
DH36	07/18/90	10:20	0.62	2024.431	20.071	0.051	337.29	Combined with 0.41 liters from 07/17/90. Used 1.03 liters for calculation.
DH36	07/25/90	09:45	0.61	2031.406	6.975	0.087	337.90	
DH36	08/01/90	10:38	0.61	2038.443	7.037	0.087	338.51	
DH36	12/12/90	09:47	11.54	2171.408	132.965	0.087	350.05	First evacuation since 08/07/90.
DH36	12/19/90	11:22	3.61	2178.474	0.000	0.000	353.66	Combined with 11.54 liters from 12/12/90. Brine stored in fractures may have drained into hole after evacuation of 11.5 liters on 12/12/90. Used 140.03 days, 15.15 liters.
DH36	01/09/91	09:50	2.34	2199.410	28.002	0.212	356.00	
DH36	01/16/91	08:35	0.73	2206.358	6.948	0.105	356.73	
DH36	01/23/91	08:35	0.54	2213.358	7.000	0.077	357.27	

TABLE A-2 (Continued)
BRINE ACCUMULATION DATA TABLE
 Data through December 31, 1993

LOCATION	DATE	TIME	LITERS REMOVED	DAYS SINCE 1/1/85	DAYS USED FOR CALCULATION	LITERS PER DAY	CUMULATIVE LITERS COLLECTED	REMARKS
DH36	02/13/91	10:30	1.90	2234.438	21.080	0.090	359.17	
DH36	02/20/91	10:30	0.58	2241.438	7.000	0.083	359.75	
DH36	02/27/91	09:58	0.32	2248.415	6.977	0.046	360.07	
DH36	03/07/91	09:45	0.02	2256.406	0.000	0.000	360.09	Partial evacuation.
DH36	03/20/91	10:07	2.72	2269.422	0.000	0.000	362.81	Partial evacuation. First evacuation with bailer, second with pump. Sampler malfunctioning.
DH36	03/21/91	08:30	0.38	2270.354	21.939	0.142	363.19	Combined with 0.02 liters from 03/07/91 and 2.72 liters from 03/20/91. Repaired sampler.
DH36	03/28/91	10:40	0.90	2277.444	7.090	0.127	364.09	
DH36	04/10/91	8:25	0.87	2290.337	0.000	0.000	364.96	Partial evacuation.
DH36	04/11/91	08:55	0.64	2291.372	13.928	0.108	365.60	Combined with 0.87 liters from 04/10/91.
DH36	04/17/91	10:34	0.63	2297.440	6.068	0.104	366.23	
DH36	04/24/91	09:15	0.52	2304.385	6.945	0.075	366.75	
DH36	05/01/91	09:26	0.65	2311.393	7.008	0.093	367.40	
DH36	05/08/91	08:37	0.42	2318.359	6.966	0.060	367.82	
DH36	05/15/91	09:14	0.62	2325.385	0.000	0.000	368.44	Partial evacuation.
DH36	05/29/91	09:30	2.75	2339.396	21.037	0.160	371.19	Combined with 0.62 liters from 05/15/91.
DH36	06/05/91	13:50	0.52	2346.576	7.180	0.072	371.71	
DH36	06/12/91	10:20	0.60	2353.431	6.855	0.088	372.31	
DH36	06/19/91	14:10	0.53	2360.590	7.159	0.074	372.84	
DH36	06/26/91	08:55	0.58	2367.372	6.782	0.086	373.42	
DH36	07/11/91	10:26	0.70	2382.435	15.063	0.046	374.12	
DH36	07/17/91	09:35	0.59	2388.399	0.000	0.000	374.71	Partial evacuation.
DH36	07/18/91	09:59	0.52	2389.416	6.981	0.159	375.23	Combined with 0.59 liters from 07/17/91.
DH36	07/30/91	10:35	0.60	2401.441	0.000	0.000	375.83	Partial evacuation.
DH36	07/31/91	09:35	0.72	2402.399	0.000	0.000	376.55	Partial evacuation.
DH36	08/01/91	10:30	0.83	2403.438	0.000	0.000	377.38	Partial evacuation.
DH36	08/02/91	10:00	0.54	2404.417	15.001	0.179	377.92	Combined with 0.60 liters from 07/30/91, 0.72 liters from 07/31/91, and 0.83 liters from 08/01/91.
DH36	08/08/91	09:23	0.51	2410.391	0.000	0.000	378.43	Some brine may have been left in hole.
DH36	08/14/91	10:04	1.63	2416.419	12.002	0.178	380.06	Combined with 0.51 liters from 08/08/91. Used bailer.
DH36	08/21/91	11:00	0.55	2423.458	0.000	0.000	380.61	Partial evacuation.
DH36	08/22/91	10:00	0.53	2424.417	7.998	0.135	381.14	Combined with 0.55 liters from 08/21/91
DH36	08/28/91	09:50	0.98	2430.410	5.993	0.164	382.12	
DH36	09/25/91	11:25	3.12	2458.476	28.066	0.111	385.24	
DH36	10/23/91	09:50	3.25	2486.410	27.934	0.116	388.49	
DH36	11/20/91	11:10	3.00	2514.465	28.055	0.107	391.49	
DH36	12/18/91	09:25	2.55	2542.392	27.927	0.091	394.04	
DH36	01/22/92	08:53	3.11	2577.370	34.978	0.089	397.15	Sampled for SNL project.
DH36	02/19/92	08:45	2.66	2605.365	27.995	0.095	399.81	
DH36	03/25/92		3.53	2640.000	34.635	0.102	403.34	
DH36	04/22/92	09:15	2.81	2668.385	28.385	0.099	406.15	
DH36	05/27/92	11:00	3.78	2703.458	35.073	0.108	409.93	

TABLE A-2 (Continued)
BRINE ACCUMULATION DATA TABLE
 Data through December 31, 1993

LOCATION	DATE	TIME	LITERS REMOVED	DAYS	DAYS	LITERS PER DAY	CUMULATIVE	REMARKS
				SINCE 1/1/85	USED FOR CALCULATION		LITERS COLLECTED	
DH36	06/25/92	09:25	4.0	2732.392	28.934	0.138	413.93	
DH36	07/29/92	09:30	4.17	2766.396	34.004	0.123	418.10	Saved for SNL.
DH36	08/20/92	08:50	1.00	2788.368	0.000	0.000	419.10	Partial evacuation for BSEP analytical program.
DH36	09/09/92	10:25	4.45	2808.434	42.038	0.130	423.55	Combine with 1.0 liter evacuated on 08-20-92.
DH36	11/11/92	09:00	8.23	2871.375	62.941	0.131	431.78	
DH36	02/26/93	09:30	13.85	2978.396	107.021	0.129	445.63	
DH36	04/28/93	10:20	8.40	3039.431	61.035	0.138	454.03	
DH36	06/16/93	11:10	7.75	3088.465	49.034	0.158	461.78	Used bailer.
DH36	08/18/93	14:00	8.17	3151.583	63.118	0.129	469.95	Used bailer.
DH36	11/12/93	10:07	11.63	3237.422	85.839	0.135	481.58	Used bailer.
DH38	12/05/84	00:00	NA	0.000	0.000	0.000	0.00	Approximate date this part of Room G excavated.
DH38	01/26/85	00:00	NA	25.000	52.000	0.000	0.00	Downhole drilled 1/25/85 to 1/26/85.
DH38	01/28/85	09:00	NA	27.375	2.375	0.000	0.00	Dry.
DH38	02/05/85	11:15	NA	35.469	8.094	0.000	0.00	Wet at bottom.
DH38	02/19/85	12:10	00.80	49.507	14.038	0.057	0.80	Brine and fine muck.
DH38	02/26/85	10:45	01.26	56.448	6.941	0.182	2.06	Brine and fine muck.
DH38	03/05/85	10:00	00.45	63.417	6.969	0.065	2.51	
DH38	03/12/85	10:00	00.39	70.417	7.000	0.056	2.90	
DH38	03/20/85	10:37	00.45	78.442	8.025	0.056	3.35	
DH38	03/26/85	09:50	00.36	84.410	5.968	0.060	3.71	
DH38	04/02/85	10:25	00.41	91.434	7.024	0.058	4.12	Some muck.
DH38	04/10/85	10:31	00.44	99.438	8.004	0.055	4.56	
DH38	04/17/85	13:30	00.41	106.563	7.125	0.058	4.97	
DH38	04/23/85	11:41	00.34	112.487	5.924	0.057	5.31	
DH38	04/30/85	11:05	00.39	119.462	6.975	0.056	5.70	
DH38	05/07/85	09:50	00.42	126.410	6.948	0.060	6.12	
DH38	05/14/85	10:45	00.41	133.448	7.038	0.058	6.53	
DH38	05/21/85	10:35	00.41	140.441	6.993	0.059	6.94	
DH38	05/29/85	11:35	00.47	148.483	8.042	0.058	7.41	
DH38	06/04/85	11:25	00.35	154.476	5.993	0.058	7.76	
DH38	06/11/85	10:35	00.40	161.441	6.965	0.057	8.16	
DH38	06/18/85	10:09	00.39	168.423	6.982	0.056	8.55	
DH38	06/25/85	10:50	00.42	175.451	7.028	0.060	8.97	
DH38	07/02/85	11:00	00.44	182.458	7.007	0.063	9.41	
DH38	07/09/85	11:05	00.43	189.462	7.004	0.061	9.84	
DH38	07/16/85	11:45	00.43	196.490	7.028	0.061	10.27	Brine effervesces.
DH38	07/24/85	10:35	00.49	204.441	7.951	0.062	10.76	
DH38	07/30/85	10:14	00.38	210.426	5.985	0.063	11.14	
DH38	08/06/85	10:34	00.42	217.440	7.014	0.060	11.56	
DH38	08/14/85	10:51	00.49	225.452	8.012	0.061	12.05	
DH38	08/20/85	11:02	00.37	231.460	6.008	0.062	12.42	
DH38	08/28/85	10:00	00.51	239.417	7.957	0.064	12.93	

TABLE A-2 (Continued)
BRINE ACCUMULATION DATA TABLE
 Data through December 31, 1993

LOCATION	DATE	TIME	LITERS REMOVED	DAYS SINCE 1/1/85	DAYS USED FOR CALCULATION	LITERS PER DAY	CUMULATIVE LITERS COLLECTED	REMARKS
DH38	09/04/85	10:23	00.44	246.433	7.016	0.063	13.37	
DH38	09/10/85	10:19	00.39	252.430	5.997	0.065	13.76	
DH38	09/17/85	09:37	00.44	259.401	6.971	0.063	14.20	
DH38	09/24/85	09:45	00.44	266.406	7.005	0.063	14.64	
DH38	10/01/85	09:53	00.44	273.412	7.006	0.063	15.08	
DH38	10/08/85	10:38	00.46	280.443	7.031	0.065	15.54	
DH38	10/15/85	10:15	00.44	287.427	6.984	0.063	15.98	
DH38	10/23/85	10:20	00.49	295.431	8.004	0.061	16.47	
DH38	10/29/85	09:40	00.39	301.403	5.972	0.065	16.86	
DH38	11/05/85	09:14	00.43	308.385	6.982	0.062	17.29	
DH38	11/13/85	10:00	00.52	316.417	8.032	0.065	17.81	
DH38	11/21/85	11:29	00.47	324.478	8.061	0.058	18.28	
DH38	11/26/85	11:20	00.33	329.472	4.994	0.066	18.61	
DH38	12/03/85	13:30	00.42	336.563	7.091	0.059	19.03	0.37 liters for chemical analysis, #3.
DH38	12/10/85	12:30	00.41	343.521	6.958	0.059	19.44	
DH38	01/23/86	11:20	02.70	387.472	43.951	0.061	22.14	Entry restricted since 12/10/85 due to mining activities.
DH38	01/31/86	12:10	00.53	395.507	8.035	0.066	22.67	
DH38	02/12/86	10:50	00.75	407.451	11.944	0.063	23.42	
DH38	02/19/86	11:40	00.43	414.486	7.035	0.061	23.85	
DH38	02/28/86	13:15	00.37	423.552	9.066	0.041	24.22	Lost substantial volume due to break in suction line. Brine flowed back down into hole.
DH38	03/06/86	10:35	00.45	429.441	5.889	0.076	24.67	
DH38	03/13/86	10:05	00.43	436.420	6.979	0.062	25.10	
DH38	03/26/86	10:10	00.59	449.424	13.004	0.045	25.69	
DH38	04/02/86	09:35	00.58	456.399	6.975	0.083	26.27	
DH38	04/08/86	09:40	00.35	462.403	6.004	0.058	26.62	
DH38	04/16/86	12:10	00.50	470.507	8.104	0.062	27.12	
DH38	04/24/86	10:12	00.47	478.425	7.918	0.059	27.59	
DH38	04/30/86	10:50	00.35	484.451	6.026	0.058	27.94	
DH38	05/06/86	10:14	00.31	490.426	5.975	0.052	28.25	
DH38	05/13/86	11:05	00.41	497.462	7.036	0.058	28.66	
DH38	05/20/86	11:05	00.40	504.462	7.000	0.057	29.06	
DH38	05/27/86	15:40	00.38	511.653	7.191	0.053	29.44	
DH38	06/03/86	10:05	00.44	518.420	6.767	0.065	29.88	
DH38	06/10/86	11:22	00.43	525.474	7.054	0.061	30.31	
DH38	06/17/86	10:50	00.37	532.451	6.977	0.053	30.68	Sample for brine chemistry, #23.
DH38	06/24/86	10:52	00.50	539.453	7.002	0.071	31.18	
DH38	07/01/86	14:01	00.40	546.584	7.131	0.056	31.58	
DH38	07/08/86	10:30	00.38	553.438	6.854	0.055	31.96	
DH38	07/16/86	10:34	00.43	561.440	8.002	0.054	32.39	
DH38	07/22/86	09:58	00.35	567.415	5.975	0.059	32.74	
DH38	07/29/86	10:40	00.38	574.444	7.029	0.054	33.12	
DH38	08/05/86	11:10	00.39	581.465	7.021	0.056	33.51	
DH38	08/12/86	10:30	00.40	588.438	6.973	0.057	33.91	
DH38	08/19/86	11:30	00.41	595.479	7.041	0.058	34.32	

TABLE A-2 (Continued)
BRINE ACCUMULATION DATA TABLE
 Data through December 31, 1993

LOCATION	DATE	TIME	LITERS REMOVED	DAYS	DAYS	LITERS PER DAY	CUMULATIVE	REMARKS
				SINCE 1/1/85	USED FOR CALCULATION		LITERS COLLECTED	
DH38	08/26/86	10:32	00.36	602.439	6.960	0.052	34.68	Static level not measured.
DH38	09/04/86	10:35	00.49	611.441	9.002	0.054	35.17	
DH38	09/09/86	10:00	00.30	616.417	4.976	0.060	35.47	Sample #25.
DH38	09/16/86	10:11	00.38	623.424	7.007	0.054	35.85	
DH38	09/23/86	10:10	00.37	630.424	7.000	0.053	36.22	
DH38	10/01/86	12:07	00.43	638.505	8.081	0.053	36.65	
DH38	10/08/86	11:30	00.36	645.479	6.974	0.052	37.01	
DH38	10/14/86	11:45	00.35	651.490	6.011	0.058	37.36	
DH38	11/05/86	11:26	1.10	673.476	21.986	0.050	38.46	
DH38	11/20/86	12:27	00.82	688.519	15.043	0.055	39.28	
DH38	12/30/86	12:15	01.87	728.510	39.991	0.047	41.15	Brown color, pH. 5.89.
DH38	02/03/87	13:15	01.72	763.552	35.042	0.049	42.87	
DH38	03/06/87	11:05	1.58	794.462	30.910	0.051	44.45	
DH38	03/30/87	11:13	1.17	818.467	24.005	0.049	45.62	
DH38	05/07/87	11:20	1.89	856.472	38.005	0.050	47.51	
DH38	06/17/87	10:45	1.91	897.448	0.000	0.000	49.42	Samples removed for chemistry, #106A, #109A, #109B. Some brine left in hole, no calculation.
DH38	06/18/87	12:05	0.16	898.503	42.031	0.049	49.58	Calculated using 2.07 liters (1.91 liters 6/17/87 plus 0.16 liters 6/18/87).
DH38	07/28/87	10:53	1.88	938.453	39.950	0.047	51.46	Collected for chemistry, sample #106.
DH38	09/01/87	10:45	1.70	973.448	34.995	0.049	53.16	Collected for chemistry, sample #152 A&B.
DH38	10/20/87	11:40	2.29	1022.486	49.038	0.047	55.45	
DH38	11/19/87	11:05	1.42	1052.462	29.976	0.047	56.87	Collected for chemistry, sample #230.
DH38	01/04/88	11:35	2.05	1098.483	46.021	0.045	58.92	
DH38	02/08/88	11:40	1.48	1133.486	35.003	0.042	60.40	Collected for chemistry, sample #258, #259 & #260.
DH38	03/29/88	11:30	2.10	1183.479	49.993	0.042	62.50	Collected for chemistry, sample #363 - #366.
DH38	05/05/88	09:55	1.70	1220.413	36.934	0.046	64.20	Sampled for SNL/NM PA.
DH38	05/12/88	11:20	0.31	1227.472	7.059	0.044	64.51	Sampled for SNL/NM PA.
DH38	07/12/88	08:45	2.44	1288.365	60.893	0.040	66.95	Collected for chemistry, sample #417 - #421.
DH38	07/28/88	10:20	0.88	1304.431	16.066	0.055	67.83	Sampled for SNL/NM PA.
DH38	09/27/88	10:30	1.92	1365.438	61.007	0.031	69.75	Collected for chemistry, sample #533 - #536.
DH38	12/13/88	09:55	3.45	1442.413	76.975	0.045	73.20	Collected for chemistry, sample #582 - #587.
DH38	03/14/89	09:55	3.25	1533.413	91.000	0.036	76.45	Sample saved for chemistry, sample #696 - 701.
DH38	04/06/89	09:45	1.03	1556.406	22.993	0.045	77.48	
DH38	04/20/89	09:35	0.75	1570.399	13.993	0.054	78.23	
DH38	05/17/89	10:05	1.11	1597.420	27.021	0.041	79.34	
DH38	06/06/89	10:00	0.70	1617.417	19.997	0.035	80.04	Sample saved for chemistry.
DH38	06/29/89	10:30	0.64	1640.438	23.021	0.028	80.68	
DH38	07/25/89	10:27	0.92	1666.435	25.997	0.035	81.60	
DH38	08/16/89	09:57	0.81	1688.415	21.980	0.037	82.41	

TABLE A-2 (Continued)
BRINE ACCUMULATION DATA TABLE
 Data through December 31, 1993

LOCATION	DATE	TIME	LITERS REMOVED	DAYS SINCE 1/1/85	DAYS USED FOR CALCULATION	LITERS PER DAY	CUMULATIVE LITERS COLLECTED	REMARKS
DH38	09/12/89	09:20	1.16	1715.389	26.974	0.043	83.57	Sample saved for chemistry.
DH38	12/13/89	10:55	3.20	1807.455	92.066	0.035	86.77	Sample saved for chemistry, sample #899.
DH38	01/10/90	10:03	1.00	1835.419	27.964	0.036	87.77	
DH38	01/24/90	10:10	0.21	1849.424	14.005	0.015	87.98	
DH38	02/07/90	10:30	0.48	1863.438	14.014	0.034	88.46	
DH38	03/05/90	09:18	0.53	1889.388	25.950	0.020	88.99	
DH38	03/13/90	14:00	NA	1897.583	0.000	0.000	88.99	Installed sampler.
DH38	03/19/90	11:30	0.61	1903.479	0.000	0.000	89.60	Hole not completely evacuated.
DH38	03/21/90	10:30	0.57	1905.438	16.050	0.074	90.17	Combined with 0.61 liters from 03/19/90. Used 1.18 liters for calculation.
DH38	04/04/90	09:37	0.62	1919.401	13.963	0.044	90.79	
DH38	04/10/90	08:56	0.34	1925.372	5.971	0.057	91.13	
DH38	04/17/90	10:39	0.23	1932.444	7.072	0.033	91.36	
DH38	04/24/90	09:30	0.27	1939.396	6.952	0.039	91.63	
DH38	05/02/90	10:47	0.32	1947.449	8.053	0.040	91.95	
DH38	05/09/90	09:08	0.23	1954.381	6.932	0.033	92.18	
DH38	05/16/90	09:35	0.25	1961.399	7.018	0.036	92.43	
DH38	05/23/90	12:03	0.25	1968.502	7.103	0.035	92.68	
DH38	05/31/90	09:04	0.28	1976.378	7.876	0.036	92.96	
DH38	06/06/90	09:40	0.22	1982.403	6.025	0.037	93.18	
DH38	06/14/90	08:53	0.27	1990.370	7.967	0.034	93.45	
DH38	06/20/90	09:49	0.22	1996.409	6.039	0.036	93.67	
DH38	06/28/90	09:15	0.29	2004.385	7.976	0.036	93.96	
DH38	07/17/90	11:30	0.50	2023.479	0.000	0.000	94.46	
DH38	07/18/90	10:40	0.20	2024.444	20.059	0.035	94.66	Combined with 0.50 liters from 07/17/90. Used 0.70 liters for calculation.
DH38	07/25/90	09:42	0.30	2031.404	6.960	0.043	94.96	
DH38	08/01/90	10:30	0.14	2038.438	7.034	0.020	95.10	
DH38	03/07/91	09:30	5.55	2256.396	0.000	0.000	100.65	Some brine may have been left in hole. Access denied due to unsound back. Sampler still functioning after 5 months. Rock bolting in "G
DH38	03/20/91	09:51	1.67	2269.410	230.972	0.031	102.32	Combined with 5.55 liters from 03/07/91. First evacuation with bailer, second with pump. Brine probably draining from fractures/storage.
DH38	03/28/91	10:32	0.52	2277.439	8.029	0.065	102.84	
DH38	04/10/91	8:34	0.40	2290.336	0.000	0.000	103.24	Partial evacuation.
DH38	04/11/91	08:50	0.03	2291.368	13.929	0.031	103.27	Combined with 0.40 liters from 04/10/91.
DH38	04/17/91	10:36	0.10	2297.442	6.074	0.016	103.37	
DH38	04/24/91	09:15	0.34	2304.385	6.943	0.049	103.71	
DH38	05/01/91	09:22	0.23	2311.390	7.005	0.033	103.94	
DH38	05/08/91	08:30	0.23	2318.354	6.964	0.033	104.17	
DH38	05/15/91	09:10	0.23	2325.382	7.028	0.033	104.40	
DH38	05/29/91	09:45	0.46	2339.406	14.024	0.033	104.86	
DH38	06/05/91	13:45	0.18	2346.573	7.167	0.025	105.04	
DH38	06/12/91	10:15	0.27	2353.427	6.854	0.039	105.31	

TABLE A-2 (Continued)
BRINE ACCUMULATION DATA TABLE
 Data through December 31, 1993

LOCATION	DATE	TIME	LITERS REMOVED	DAYS	DAYS	LITERS PER DAY	CUMULATIVE	REMARKS
				SINCE 1/1/85	USED FOR CALCULATION		LITERS COLLECTED	
DH38	06/19/91	13:54	0.25	2360.579	7.152	0.035	105.56	
DH38	06/26/91	09:01	0.00	2367.376	0.000	0.000	105.56	No Vacuum, clamp failed.
DH38	07/11/91	10:35	0.58	2382.441	21.862	0.027	106.14	
DH38	07/17/91	09:30	0.31	2388.396	5.955	0.052	106.45	
DH38	07/30/91	10:20	0.45	2401.431	13.035	0.035	106.90	
DH38	08/08/91	09:18	0.32	2410.388	8.957	0.036	107.22	
DH38	08/14/91	10:35	0.22	2416.441	6.053	0.036	107.44	
DH38	08/21/91	10:55	0.23	2423.455	7.014	0.033	107.67	
DH38	08/28/91	10:20	0.17	2430.431	6.976	0.024	107.84	
DH38	09/04/91	11:18	0.25	2437.471	7.040	0.036	108.09	
DH38	09/11/91	11:50	0.23	2444.493	7.022	0.033	108.32	
DH38	09/18/91	09:20	0.26	2451.389	6.896	0.038	108.58	
DH38	09/25/91	12:00	0.25	2458.500	7.111	0.035	108.83	
DH38	10/02/91	11:09	0.23	2465.465	6.965	0.033	109.06	
DH38	10/16/91	09:30	0.46	2479.396	13.931	0.033	109.52	
DH38	10/23/91	09:45	0.16	2486.406	0.000	0.000	109.68	Some brine may have been left in hole. Hose broke, lost vacuum.
DH38	10/31/91	09:43	0.45	2494.405	15.009	0.041	110.13	Combined with 0.16 liters from 10/23/91.
DH38	11/06/91	10:07	0.22	2500.422	6.017	0.037	110.35	
DH38	11/13/91	09:25	0.24	2507.392	6.970	0.034	110.59	
DH38	11/20/91	11:15	0.24	2514.469	7.077	0.034	110.83	
DH38	11/27/91	09:55	0.24	2521.413	6.944	0.035	111.07	
DH38	12/04/91	09:52	0.24	2528.411	6.998	0.034	111.31	
DH38	12/11/91	09:35	0.22	2535.399	6.988	0.031	111.53	
DH38	12/18/91	09:20	0.00	2542.389	0.000	0.000	111.53	Some brine may have been left in hole. Vacuum gone.
DH38	12/23/91	08:45	0.37	2547.365	11.966	0.031	111.90	
DH38	01/08/92	09:55	0.51	2563.413	16.048	0.032	112.41	
DH38	01/15/92	09:50	0.25	2570.410	6.997	0.036	112.66	
DH38	01/22/92	08:47	0.23	2577.366	6.956	0.033	112.89	
DH38	01/29/92	10:01	0.23	2584.417	7.051	0.033	113.12	
DH38	02/12/92	08:59	0.42	2598.374	13.957	0.030	113.54	
DH38	02/19/92	09:00	0.33	2605.375	7.001	0.047	113.87	
DH38	02/26/92	09:50	0.24	2612.410	7.035	0.034	114.11	
DH38	03/11/92	09:45	0.43	2626.406	13.996	0.031	114.54	
DH38	03/18/92	09:55	0.24	2633.413	7.007	0.034	114.78	
DH38	03/25/92	10:15	0.23	2640.427	7.014	0.033	115.01	
DH38	04/01/92	09:20	0.25	2647.389	6.962	0.036	115.26	
DH38	04/07/92	09:25	0.19	2653.392	6.003	0.032	115.45	
DH38	04/15/92	09:20	0.31	2661.389	7.997	0.039	115.76	
DH38	04/22/92	09:38	0.22	2668.401	7.012	0.031	115.98	
DH38	05/06/92	11:25	0.45	2682.476	0.000	0.000	116.43	Partial evacuation, some brine left in hole.
DH38	05/07/92	09:35	0.07	2683.399	14.998	0.035	116.50	Combine with 0.45 liters removed 05/06/92 for total volume.
DH38	05/13/92	13:50	0.21	2689.576	6.177	0.034	116.71	
DH38	05/21/92	10:33	0.27	2697.440	7.864	0.034	116.98	

TABLE A-2 (Continued)
BRINE ACCUMULATION DATA TABLE
 Data through December 31, 1993

LOCATION	DATE	TIME	LITERS REMOVED	DAYS	DAYS	LITERS PER DAY	CUMULATIVE	REMARKS
				SINCE 1/1/85	USED FOR CALCULATION		LITERS COLLECTED	
DH38	05/27/92	09:25	0.00	2703.392	0.000	0.000	116.98	No vacuum.
DH38	06/09/92	09:25	0.51	2716.392	18.952	0.027	117.49	
DH38	06/18/92	10:05	0.42	2725.420	9.028	0.047	117.91	
DH38	06/25/92	09:55	0.25	2732.413	6.993	0.036	118.16	
DH38	07/01/92	09:36	0.33	2738.400	5.987	0.055	118.49	
DH38	07/08/92	09:35	0.15	2745.399	6.999	0.021	118.64	
DH38	07/15/92	09:30	0.24	2752.396	6.997	0.034	118.88	
DH38	07/22/92	09:20	0.29	2759.389	6.993	0.041	119.17	
DH38	07/29/92	10:05	0.26	2766.420	7.031	0.037	119.43	
DH38	08/04/92	09:53	0.25	2772.412	5.992	0.042	119.68	
DH38	08/18/92	10:22	0.38	2786.432	14.020	0.027	120.06	
DH38	09/02/92	10:20	0.56	2801.431	14.999	0.037	120.62	
DH38	09/09/92	10:15	0.34	2808.427	6.996	0.049	120.96	
DH38	09/17/92	09:25	0.23	2816.392	7.965	0.029	121.19	
DH38	09/23/92	10:15	0.24	2822.427	6.035	0.040	121.43	
DH38	09/30/92	11:15	0.27	2829.469	7.042	0.038	121.70	
DH38	10/12/92	12:50	0.38	2841.535	12.066	0.031	122.08	
DH38	10/21/92		0.38	2850.000	8.465	0.045	122.46	
DH38	10/28/92	09:25	0.28	2857.392	7.392	0.038	122.74	
DH38	11/11/92	09:45	0.43	2871.406	14.014	0.031	123.17	
DH38	11/18/92	13:22	0.36	2878.557	7.151	0.050	123.53	
DH38	11/25/92	09:45	0.26	2885.406	6.849	0.038	123.79	
DH38	12/09/92	12:55	0.28	2899.538	14.132	0.020	124.07	
DH38	12/16/92	10:25	0.42	2906.434	6.896	0.061	124.49	
DH38	01/07/93	08:45	0.35	2928.365	21.931	0.016	124.84	
DH38	01/13/93	09:40	0.53	2934.403	6.038	0.088	125.37	
DH38	01/28/93	10:35	0.50	2949.441	15.038	0.033	125.87	
DH38	02/11/93	10:00	0.50	2963.417	13.976	0.036	126.37	
DH38	02/26/93	10:50	0.40	2978.451	15.034	0.027	126.77	
DH38	03/10/93	10:45	0.35	2990.448	11.997	0.029	127.12	
DH38	03/19/93	09:25	0.46	2999.392	8.944	0.051	127.58	
DH38	03/25/93	10:35	0.44	3005.441	6.049	0.073	128.02	
DH38	03/31/93	13:25	0.27	3011.559	6.118	0.044	128.29	
DH38	04/28/93	09:30	0.22	3039.396	0.000	0.000	128.51	Partial evacuation.
DH38	06/16/93	11:20	1.11	3088.472	76.913	0.017	129.62	Used bailer. Combine with 0.22 liters from 04-28-93.
DH38	08/18/93	14:19	0.28	3151.597	0.000	0.000	129.90	Partial evacuation. Unable to sample since 06-16-93.
DH38	08/19/93	14:02	2.10	3152.585	0.000	0.000	132.00	Partial evacuation.
DH38	08/20/93	09:56	0.33	3153.414	64.942	0.042	132.33	Combine with 0.28 liters from 08-18-93 and 2.10 liters from 08-19-93.
DH38	11/12/93	10:41	3.01	3237.445	84.031	0.036	135.34	Used bailer.
DH40	12/13/84	00:00	NA	0.000	0.000	0.000	0.00	Approximate date this part of Room G excavated.
DH40	01/25/85	00:00	NA	24.000	43.000	0.000	0.00	Downhole drilled 1/24/85 to 1/25/85.

TABLE A-2 (Continued)
BRINE ACCUMULATION DATA TABLE
 Data through December 31, 1993

LOCATION	DATE	TIME	LITERS REMOVED	DAYS	DAYS	LITERS PER DAY	CUMULATIVE	REMARKS
				SINCE 1/1/85	USED FOR CALCULATION		LITERS COLLECTED	
DH40	01/28/85	09:00	NA	27.375	3.375	0.000	0.00	Dry.
DH40	02/05/85	11:15	NA	35.469	8.094	0.000	0.00	Moist at bottom.
DH40	03/12/85	10:10	NA	70.424	34.955	0.000	0.00	Moist muck.
DH40	03/26/85	09:55	NA	84.413	13.989	0.000	0.00	Moist muck.
DH40	04/17/85	13:30	00.98	106.563	22.150	0.044	0.98	Brine, muck, and oil.
DH40	04/23/85	11:33	00.26	112.481	5.918	0.044	1.24	Brine and muck.
DH40	04/30/85	10:49	00.11	119.451	6.970	0.016	1.35	Feel something spongy in bottom of hole.
DH40	05/07/85	09:42	00.10	126.404	6.953	0.014	1.45	
DH40	05/14/85	10:40	00.09	133.444	7.040	0.013	1.54	
DH40	05/21/85	10:26	00.07	140.435	6.991	0.010	1.61	
DH40	05/29/85	11:30	00.08	148.479	8.044	0.010	1.69	
DH40	06/04/85	11:15	00.10	154.469	5.990	0.017	1.79	Salt muck in hole.
DH40	06/11/85	10:30	00.05	161.438	6.969	0.007	1.84	
DH40	06/18/85	10:01	00.09	168.417	6.979	0.013	1.93	
DH40	06/25/85	11:00	00.08	175.458	7.041	0.011	2.01	
DH40	07/02/85	11:00	00.09	182.458	7.000	0.013	2.10	
DH40	07/09/85	10:45	00.12	189.448	6.990	0.017	2.22	
DH40	07/16/85	11:38	00.09	196.485	7.037	0.013	2.31	
DH40	07/24/85	10:31	00.07	204.438	7.953	0.009	2.38	
DH40	07/30/85	10:08	00.07	210.422	5.984	0.012	2.45	
DH40	08/06/85	10:20	00.06	217.431	7.009	0.009	2.51	
DH40	08/14/85	10:43	00.07	225.447	8.016	0.009	2.58	
DH40	08/20/85	10:50	00.05	231.451	6.004	0.008	2.63	
DH40	08/28/85	09:53	00.08	239.412	7.961	0.010	2.71	
DH40	09/04/85	10:18	00.03	246.429	7.017	0.004	2.74	
DH40	09/10/85	10:11	00.04	252.424	5.995	0.007	2.78	
DH40	09/17/85	09:31	00.03	259.397	6.973	0.004	2.81	
DH40	09/24/85	09:40	00.06	266.403	7.006	0.009	2.87	
DH40	10/01/85	09:47	00.06	273.408	7.005	0.009	2.93	
DH40	10/08/85	10:32	00.04	280.439	7.031	0.006	2.97	
DH40	10/15/85	10:05	00.09	287.420	6.981	0.013	3.06	
DH40	10/23/85	10:13	00.04	295.426	8.006	0.005	3.10	
DH40	10/29/85	09:32	00.07	301.397	5.971	0.012	3.17	
DH40	11/05/85	09:10	00.04	308.382	6.985	0.006	3.21	
DH40	11/13/85	09:55	00.07	316.413	8.031	0.009	3.28	
DH40	11/21/85	11:24	00.02	324.475	8.062	0.002	3.30	
DH40	12/03/85	13:20	00.08	336.556	12.081	0.007	3.38	
DH40	12/10/85	12:40	00.04	343.528	6.972	0.006	3.42	
DH40	01/23/86	11:25	00.24	387.476	43.948	0.005	3.66	Entry restricted since 12/10/85 due to mining activities.
DH40	01/31/86	12:10	00.02	395.507	8.031	0.002	3.68	
DH40	02/19/86	11:20	00.14	414.472	18.965	0.007	3.82	
DH40	02/28/86	13:10	00.05	423.549	9.077	0.006	3.87	
DH40	03/13/86	10:00	00.02	436.417	12.868	0.002	3.89	
DH40	04/24/86	10:05	00.13	478.420	42.003	0.003	4.02	
DH40	05/20/86	11:05	00.10	504.462	26.042	0.004	4.12	
DH40	06/03/86	09:58	00.20	518.415	13.953	0.014	4.32	

TABLE A-2 (Continued)
BRINE ACCUMULATION DATA TABLE
 Data through December 31, 1993

LOCATION	DATE	TIME	LITERS REMOVED	DAYS	DAYS	LITERS PER DAY	CUMULATIVE	REMARKS
				SINCE 1/1/85	USED FOR CALCULATION		LITERS COLLECTED	
DH40	09/16/86	10:05	00.34	623.420	105.005	0.003	4.66	Did not collect for several months.
DH40	11/05/86	11:18	0.27	673.471	50.051	0.005	4.93	
DH40	12/30/86	12:00	00.25	728.500	55.029	0.005	5.18	Very dirty, pH 6.00.
DH40	02/03/87	13:00	00.13	763.542	35.042	0.004	5.31	
DH40	03/06/87	10:55	0.09	794.455	30.913	0.003	5.40	
DH40	03/30/87	11:05	0.10	818.462	24.007	0.004	5.50	
DH40	06/18/87	12:00	0.19	898.500	80.038	0.002	5.69	
DH40	09/01/87	10:25	0.16	973.434	74.934	0.002	5.85	
DH40	02/08/88	11:30	0.55	1133.479	160.045	0.003	6.40	Collected for chemistry, sample #257.
DH40	03/29/88	11:25	0.14	1183.476	49.997	0.003	6.54	Collected for chemistry, sample #326.
DH40	05/12/88	11:40	0.20	1227.486	44.010	0.005	6.74	Sampled for SNL/NM PA.
DH40	07/12/88	08:40	0.15	1288.361	60.875	0.002	6.89	
DH40	09/27/88	10:25	0.21	1365.434	77.073	0.003	7.10	Collected for chemistry, sample #532.
DH40	12/13/88	09:45	0.12	1442.406	76.972	0.002	7.22	
DH40	03/15/89	10:35	Trace	1534.441	0.000	0.000	7.22	No sample. Trace of brine found.
DH40	04/06/89	09:50	0.27	1556.410	114.004	0.002	7.49	
DH40	04/20/89	09:20	0.09	1570.389	13.979	0.006	7.58	
DH40	05/17/89	10:00	0.30	1597.417	27.028	0.011	7.88	
DH40	06/06/89	09:55	0.12	1617.413	19.996	0.006	8.00	
DH40	06/29/89	10:25	Trace	1640.434	0.000	0.000	8.00	Trace of brine found.
DH40	07/25/89	10:18	0.07	1666.429	49.016	0.001	8.07	
DH40	08/16/89	09:49	0.06	1688.409	21.980	0.003	8.13	
DH40	09/12/89	09:10	Trace	1715.382	0.000	0.000	8.13	Trace of fluid in hole.
DH40	12/13/89	10:25	0.20	1807.434	119.025	0.002	8.33	
DH40	01/10/90	09:50	0.08	1835.410	27.976	0.003	8.41	
DH40	03/05/90	09:10	0.50	1889.382	53.972	0.009	8.91	
DH40	03/13/90	13:30	NA	1897.563	0.000	0.000	8.91	Installed sampler.
DH40	03/19/90	11:25	0.09	1903.476	0.000	0.000	9.00	Brine probably left in hole.
DH40	03/21/90	10:25	0.02	1905.434	16.052	0.007	9.02	Combined with 0.09 liters from 03/19/90. Used 0.11 liters for calculation.
DH40	04/04/90	09:31	0.03	1919.397	13.963	0.002	9.05	
DH40	05/02/90	10:41	0.09	1947.445	28.048	0.003	9.14	
DH40	05/16/90	09:26	0.07	1961.393	13.948	0.005	9.21	
DH40	06/14/90	11:19	0.13	1990.472	29.079	0.004	9.34	
DH40	06/20/90	09:40	0.02	1996.403	5.931	0.003	9.36	
DH40	06/28/90	09:00	0.03	2004.375	7.972	0.004	9.39	
DH40	07/17/90	11:17	0.10	2023.470	19.095	0.005	9.49	
DH40	03/20/91	09:24	0.72	2269.392	0.000	0.000	10.21	Some brine may have been left in hole. First evacuation with bailer, second with pump.
DH40	03/28/91	10:17	0.54	2277.428	253.958	0.005	10.75	Combined with 0.72 liters from 03/20/91.
DH40	04/10/91	8:40	0.10	2290.333	12.905	0.008	10.85	
DH40	04/17/91	10:22	0.04	2297.432	7.099	0.006	10.89	
DH40	05/01/91	09:20	0.10	2311.389	13.957	0.007	10.99	
DH40	05/29/91	09:50	0.16	2339.410	28.021	0.006	11.15	
DH40	06/26/91	09:05	0.17	2367.378	27.968	0.006	11.32	
DH40	07/11/91	10:40	0.11	2382.444	15.066	0.007	11.43	

TABLE A-2 (Continued)
BRINE ACCUMULATION DATA TABLE
 Data through December 31, 1993

LOCATION	DATE	TIME	LITERS REMOVED	DAYS	DAYS	LITERS PER DAY	CUMULATIVE	REMARKS
				SINCE 1/1/85	USED FOR CALCULATION		LITERS COLLECTED	
DH40	08/08/91	09:15	0.18	2410.385	27.941	0.006	11.61	
DH40	08/21/91	10:50	0.10	2423.451	13.066	0.008	11.71	
DH40	09/18/91	09:15	0.14	2451.385	27.934	0.005	11.85	
DH40	09/25/91	11:55	0.13	2458.497	7.112	0.018	11.98	
DH40	10/16/91	09:25	0.15	2479.392	20.895	0.007	12.13	
DH40	10/23/91	09:40	0.07	2486.403	7.011	0.010	12.20	
DH40	11/13/91	09:30	0.14	2507.396	20.993	0.007	12.34	
DH40	11/27/91	10:00	0.10	2521.417	14.021	0.007	12.44	
DH40	12/11/91	09:40	0.11	2535.403	13.986	0.008	12.55	
DH40	01/08/92	09:52	0.13	2563.411	28.008	0.005	12.68	
DH40	01/22/92	08:42	0.10	2577.363	13.952	0.007	12.78	
DH40	01/29/92	09:56	0.05	2584.414	7.051	0.007	12.83	
DH40	02/12/92	08:53	0.11	2598.370	13.956	0.008	12.94	
DH40	02/19/92	09:15	0.07	2605.385	7.015	0.010	13.01	
DH40	02/26/92	09:45	0.05	2612.406	7.021	0.007	13.06	
DH40	03/11/92	09:40	0.02	2626.403	13.997	0.001	13.08	
DH40	03/18/92	09:50	0.18	2633.410	7.007	0.026	13.26	
DH40	03/25/92	10:30	0.04	2640.438	7.028	0.006	13.30	
DH40	04/15/92	09:15	0.15	2661.385	20.947	0.007	13.45	
DH40	04/22/92	09:35	0.07	2668.399	7.014	0.010	13.52	
DH40	05/06/92	11:20	0.13	2682.472	14.073	0.009	13.65	
DH40	05/27/92	09:15	0.16	2703.385	20.913	0.008	13.81	
DH40	06/09/92	09:15	0.11	2716.385	13.000	0.008	13.92	
DH40	06/18/92	10:00	0.09	2725.417	9.032	0.010	14.01	
DH40	06/25/92	09:50	0.08	2732.410	6.993	0.011	14.09	
DH40	07/01/92	09:30	0.18	2738.396	5.986	0.030	14.27	
DH40	07/15/92	09:25	0.19	2752.392	13.996	0.014	14.46	
DH40	07/22/92	09:15	0.16	2759.385	6.993	0.023	14.62	
DH40	07/29/92	09:57	0.10	2766.415	7.030	0.014	14.72	
DH40	08/04/92	09:45	0.12	2772.406	5.991	0.020	14.84	
DH40	08/18/92	09:59	0.28	2786.416	14.010	0.020	15.12	
DH40	09/02/92	10:00	0.30	2801.417	15.001	0.020	15.42	
DH40	09/09/92	10:05	0.15	2808.420	7.003	0.021	15.57	
DH40	09/17/92	09:15	0.16	2816.385	7.965	0.020	15.73	
DH40	09/23/92	10:10	0.11	2822.424	6.039	0.018	15.84	
DH40	10/12/92	12:45	0.20	2841.531	19.107	0.010	16.04	
DH40	10/21/92	13:10	0.28	2850.549	9.018	0.031	16.32	
DH40	10/28/92	09:20	0.10	2857.389	6.840	0.015	16.42	
DH40	11/11/92	09:40	0.38	2871.403	14.014	0.027	16.80	
DH40	11/18/92	13:15	0.17	2878.552	7.149	0.024	16.97	
DH40	11/25/92	09:40	0.09	2885.403	6.851	0.013	17.06	
DH40	12/09/92	12:45	0.25	2899.531	14.128	0.018	17.31	
DH40	12/16/92	10:20	0.04	2906.431	6.900	0.006	17.35	
DH40	01/07/93	08:40	0.27	2928.361	21.930	0.012	17.62	
DH40	01/13/93	09:53	0.53	2934.412	6.051	0.088	18.15	
DH40	01/28/93	10:25	0.30	2949.434	15.022	0.020	18.45	
DH40	02/11/93	09:55	0.30	2963.413	13.979	0.021	18.75	

TABLE A-2 (Continued)
BRINE ACCUMULATION DATA TABLE
 Data through December 31, 1993

LOCATION	DATE	TIME	LITERS REMOVED	DAYS	DAYS	LITERS PER DAY	CUMULATIVE	REMARKS
				SINCE 1/1/85	USED FOR CALCULATION		LITERS COLLECTED	
DH40	02/26/93	10:45	0.23	2978.448	15.035	0.015	18.98	
DH40	03/10/93	10:40	0.43	2990.444	11.996	0.036	19.41	
DH40	03/19/93	09:28	0.22	2999.394	8.950	0.025	19.63	
DH40	03/25/93	10:15	0.10	3005.427	6.033	0.017	19.73	
DH40	03/31/93	13:05	0.13	3011.545	6.118	0.021	19.86	
DH40	04/28/93	09:15	0.48	3039.385	27.840	0.017	20.34	
DH40	06/16/93	11:30	0.45	3088.479	49.094	0.009	20.79	
DH40	08/19/93	14:12	0.42	3152.592	64.113	0.007	21.21	
DH40	11/12/93	10:28	0.78	3237.436	84.844	0.009	21.99	
<hr/>								
DH42	12/30/84	00:00	NA	0.000	0.000	0.000	0.00	Approximate date this part of Room G excavated.
DH42	01/23/85	00:00	NA	22.000	24.000	0.000	0.00	Downhole drilled.
DH42	01/28/85	09:00	NA	27.375	0.000	0.000	0.00	Moist muck at the bottom.
DH42	02/05/85	11:15	00.27	35.469	13.469	0.020	0.27	First time collected.
DH42	02/11/85	11:00	00.30	41.458	5.989	0.050	0.57	
DH42	02/19/85	13:10	00.33	49.549	8.091	0.041	0.90	
DH42	02/26/85	10:45	00.26	56.448	6.899	0.038	1.16	
DH42	03/05/85	10:00	00.28	63.417	6.969	0.040	1.44	
DH42	03/12/85	10:20	00.25	70.431	7.014	0.036	1.69	
DH42	03/20/85	10:54	00.25	78.454	8.023	0.031	1.94	Valve leaked, some brine drained back down hole.
DH42	03/26/85	10:06	00.28	84.421	5.967	0.047	2.22	
DH42	04/02/85	10:45	00.26	91.448	7.027	0.037	2.48	
DH42	04/10/85	10:45	00.29	99.448	8.000	0.036	2.77	
DH42	04/17/85	13:30	00.24	106.563	7.115	0.034	3.01	
DH42	04/23/85	13:23	00.04	112.558	5.995	0.007	3.05	Significant volume of brine drained back down hole.
DH42	04/30/85	10:31	00.38	119.438	6.880	0.055	3.43	
DH42	05/07/85	09:25	00.33	126.392	6.954	0.047	3.76	
DH42	05/14/85	10:30	00.25	133.438	7.046	0.035	4.01	
DH42	05/21/85	10:17	00.26	140.428	6.990	0.037	4.27	
DH42	05/29/85	10:10	00.30	148.424	7.996	0.038	4.57	
DH42	06/04/85	10:45	00.22	154.448	6.024	0.037	4.79	
DH42	06/11/85	10:10	00.25	161.424	6.976	0.036	5.04	
DH42	06/18/85	09:53	00.25	168.412	6.988	0.036	5.29	
DH42	06/25/85	11:15	00.25	175.469	7.057	0.035	5.54	
DH42	07/02/85	11:00	00.24	182.458	6.989	0.034	5.78	
DH42	07/09/85	10:30	00.25	189.438	6.980	0.036	6.03	
DH42	07/16/85	11:08	00.25	196.464	7.026	0.036	6.28	Brine effervesces.
DH42	07/24/85	10:19	00.28	204.430	7.966	0.035	6.56	
DH42	07/30/85	09:57	00.22	210.415	5.985	0.037	6.78	
DH42	08/06/85	10:13	00.26	217.426	7.011	0.037	7.04	
DH42	08/14/85	10:59	00.27	225.458	8.032	0.034	7.31	
DH42	08/20/85	10:45	00.21	231.448	5.990	0.035	7.52	
DH42	08/28/85	09:45	00.29	239.406	7.958	0.036	7.81	

TABLE A-2 (Continued)
BRINE ACCUMULATION DATA TABLE
 Data through December 31, 1993

LOCATION	DATE	TIME	LITERS REMOVED	DAYS	DAYS	LITERS PER DAY	CUMULATIVE	REMARKS
				SINCE 1/1/85	USED FOR CALCULATION		LITERS COLLECTED	
DH42	09/04/85	10:12	00.25	246.425	7.019	0.036	8.06	
DH42	09/10/85	09:56	00.21	252.414	5.989	0.035	8.27	
DH42	09/17/85	09:26	00.28	259.393	6.979	0.040	8.55	
DH42	09/24/85	09:37	00.24	266.401	7.008	0.034	8.79	
DH42	10/01/85	09:44	00.24	273.406	7.005	0.034	9.03	
DH42	10/08/85	10:25	00.23	280.434	7.028	0.033	9.26	
DH42	10/15/85	10:00	00.23	287.417	6.983	0.033	9.49	
DH42	10/23/85	10:07	00.26	295.422	8.005	0.032	9.75	
DH42	10/29/85	09:16	00.24	301.386	5.964	0.040	9.99	
DH42	11/05/85	09:05	00.22	308.378	6.992	0.031	10.21	
DH42	11/13/85	09:46	00.26	316.407	8.029	0.032	10.47	
DH42	11/21/85	10:53	00.26	324.453	8.046	0.032	10.73	
DH42	11/26/85	10:59	00.16	329.458	5.005	0.032	10.89	
DH42	12/03/85	13:10	00.20	336.549	7.091	0.028	11.09	Sample for chemistry analysis, #2.
DH42	12/10/85	12:50	00.22	343.535	6.986	0.031	11.31	
DH42	01/23/86	11:30	01.32	387.479	43.944	0.030	12.63	Entry restricted since 12/10/85 due to mining activities.
DH42	01/31/86	12:05	00.30	395.503	8.024	0.037	12.93	
DH42	02/12/86	10:35	00.38	407.441	11.938	0.032	13.31	
DH42	02/19/86	11:10	00.22	414.465	7.024	0.031	13.53	
DH42	02/28/86	13:00	00.31	423.542	9.077	0.034	13.84	
DH42	03/06/86	10:30	00.17	429.438	5.896	0.029	14.01	
DH42	03/13/86	09:53	00.21	436.412	6.974	0.030	14.22	
DH42	03/26/86	10:00	00.39	449.417	13.005	0.030	14.61	
DH42	04/02/86	09:25	00.20	456.392	6.975	0.029	14.81	
DH42	04/08/86	09:30	00.20	462.396	6.004	0.033	15.01	
DH42	04/16/86	11:55	00.24	470.497	8.101	0.030	15.25	
DH42	04/24/86	09:55	00.21	478.413	7.916	0.027	15.46	
DH42	04/30/86	10:41	00.17	484.445	6.032	0.028	15.63	
DH42	05/06/86	10:10	00.19	490.424	5.979	0.032	15.82	
DH42	05/13/86	10:00	00.20	497.417	6.993	0.029	16.02	
DH42	05/20/86	11:00	00.20	504.458	7.041	0.028	16.22	
DH42	05/27/86	15:35	00.20	511.649	7.191	0.028	16.42	
DH42	06/03/86	09:50	00.20	518.410	6.761	0.030	16.62	
DH42	06/10/86	11:13	00.17	525.467	7.057	0.024	16.79	
DH42	06/17/86	10:40	00.20	532.444	6.977	0.029	16.99	Sample for brine chemistry, #22.
DH42	06/24/86	10:40	00.18	539.444	7.000	0.026	17.17	
DH42	07/01/86	13:45	00.20	546.573	7.129	0.028	17.37	
DH42	07/08/86	10:22	00.20	553.432	6.859	0.029	17.57	
DH42	07/16/86	10:15	00.30	561.427	7.995	0.038	17.87	
DH42	07/22/86	09:50	00.16	567.410	5.983	0.027	18.03	
DH42	07/29/86	10:25	00.20	574.434	7.024	0.028	18.23	
DH42	08/05/86	11:00	00.22	581.458	7.024	0.031	18.45	
DH42	08/12/86	10:20	00.20	588.431	6.973	0.029	18.65	
DH42	08/19/86	11:20	00.18	595.472	7.041	0.026	18.83	
DH42	08/26/86	10:25	00.20	602.434	6.962	0.029	19.03	Static level not measured.
DH42	09/04/86	10:20	00.25	611.431	8.997	0.028	19.28	

TABLE A-2 (Continued)
BRINE ACCUMULATION DATA TABLE
 Data through December 31, 1993

LOCATION	DATE	TIME	LITERS REMOVED	DAYS	DAYS	LITERS PER DAY	CUMULATIVE	REMARKS
				SINCE 1/1/85	USED FOR CALCULATION		LITERS COLLECTED	
DH42	09/09/86	09:46	00.14	616.407	4.976	0.028	19.42	Sample #24.
DH42	09/16/86	09:52	00.20	623.411	7.004	0.029	19.62	
DH42	09/23/86	09:58	00.15	630.415	7.004	0.021	19.77	
DH42	10/01/86	12:03	00.36	638.502	8.087	0.045	20.13	
DH42	10/08/86	10:55	00.15	645.455	6.953	0.022	20.28	
DH42	10/14/86	11:19	00.15	651.472	6.017	0.025	20.43	
DH42	11/05/86	11:07	0.52	673.463	21.991	0.024	20.95	
DH42	11/20/86	12:10	00.33	688.507	15.044	0.022	21.28	
DH42	12/30/86	11:45	00.78	728.490	39.983	0.020	22.06	0.50 liters for sample, pH 5.91.
DH42	02/03/87	12:50	00.85	763.535	35.045	0.024	22.91	
DH42	03/06/87	10:45	0.68	794.448	30.913	0.022	23.59	
DH42	03/30/87	11:00	0.53	818.458	24.010	0.022	24.12	
DH42	05/07/87	11:15	0.90	856.469	38.011	0.024	25.02	Brine effervesces.
DH42	06/17/87	10:35	0.91	897.441	0.000	0.000	25.93	Samples removed for chemistry, #112A, #112B. Wood fragments in hole. Some brine left in hole, no calculation.
DH42	06/18/87	11:56	0.10	898.497	42.028	0.024	26.03	Calculated using 1.01 liters (0.91 liters 6/17/87 plus 0.10 liters 6/18/87).
DH42	07/28/87	11:10	0.94	938.465	39.968	0.024	26.97	
DH42	09/01/87	10:15	0.79	973.427	34.962	0.023	27.76	Collected for chemistry, sample #151 A&B.
DH42	10/20/87	11:31	1.29	1022.480	49.053	0.026	29.05	
DH42	11/19/87	10:55	0.75	1052.455	29.975	0.025	29.80	Collected for chemistry, sample #229.
DH42	01/04/88	11:30	1.13	1098.479	46.024	0.025	30.93	
DH42	02/08/88	11:20	0.75	1133.472	34.993	0.021	31.68	Collected for chemistry, sample #255 & #256.
DH42	03/29/88	11:20	1.10	1183.472	50.000	0.022	32.78	Collected for chemistry, sample #323 - #325.
DH42	05/05/88	09:30	0.75	1220.396	36.924	0.020	33.53	Sampled for SNL/NM PA.
DH42	05/12/88	09:45	0.13	1227.406	7.010	0.019	33.66	Sampled for SNL/NM PA.
DH42	07/12/88	08:35	1.15	1288.358	60.952	0.019	34.81	Collected for chemistry, sample #415 & #416.
DH42	07/28/88	10:10	0.34	1304.424	16.066	0.021	35.15	Sampled for SNL/NM PA.
DH42	09/27/88	10:20	0.66	1365.431	61.007	0.011	35.81	Collected for chemistry, sample #530 & #531.
DH42	12/13/88	09:38	1.71	1442.401	76.970	0.022	37.52	Collected for chemistry. sample #628 - #631.
DH42	03/15/89	10:30	1.50	1534.438	92.037	0.016	39.02	Sample saved for chemistry, sample #722 - 724.
DH42	04/06/89	10:10	0.54	1556.424	21.986	0.025	39.56	
DH42	04/20/89	09:10	0.50	1570.382	13.958	0.036	40.06	
DH42	05/17/89	09:45	0.66	1597.406	27.024	0.024	40.72	
DH42	06/06/89	09:50	0.41	1617.410	20.004	0.020	41.13	Sample saved for chemistry.
DH42	06/29/89	10:20	0.35	1640.431	23.021	0.015	41.48	
DH42	07/25/89	10:10	0.55	1666.424	25.993	0.021	42.03	Sample saved for SNL brine study.
DH42	08/16/89	09:40	0.36	1688.403	21.979	0.016	42.39	
DH42	09/12/89	09:00	0.35	1715.375	26.972	0.013	42.74	Sample saved for chemistry.
DH42	12/13/89	10:03	1.50	1807.419	92.044	0.016	44.24	Sample saved for chemistry, sample #898.

TABLE A-2 (Continued)
BRINE ACCUMULATION DATA TABLE
 Data through December 31, 1993

LOCATION	DATE	TIME	LITERS REMOVED	DAYS	DAYS	LITERS PER DAY	CUMULATIVE	REMARKS
				SINCE 1/1/85	USED FOR CALCULATION		LITERS COLLECTED	
DH42	01/10/90	09:45	0.70	1835.406	27.987	0.025	44.94	
DH42	01/24/90	09:57	0.27	1849.415	14.009	0.019	45.21	
DH42	02/07/90	10:23	0.34	1863.433	14.018	0.024	45.55	
DH42	02/21/90	10:19	0.32	1877.430	13.997	0.023	45.87	
DH42	03/05/90	09:00	0.36	1889.375	11.945	0.030	46.23	
DH42	03/13/90	12:00	NA	1897.500	0.000	0.000	46.23	Installed sampler.
DH42	03/19/90	11:12	0.06	1903.467	14.092	0.004	46.29	Brine probably left in hole.
DH42	03/21/90	10:23	0.08	1905.433	1.966	0.041	46.37	Combined with 0.06 liters from 03/19/90. Used 0.14 liters for calculation.
DH42	04/04/90	09:24	0.24	1919.392	13.959	0.017	46.61	
DH42	04/10/90	08:43	0.14	1925.363	5.971	0.023	46.75	
DH42	04/17/90	10:29	0.14	1932.437	7.074	0.020	46.89	
DH42	04/24/90	09:26	0.13	1939.393	6.956	0.019	47.02	
DH42	05/02/90	10:39	0.15	1947.444	8.051	0.019	47.17	
DH42	05/09/90	09:01	0.13	1954.376	6.932	0.019	47.30	
DH42	05/16/90	09:11	0.13	1961.383	7.007	0.019	47.43	
DH42	05/23/90	12:08	0.14	1968.506	7.123	0.020	47.57	
DH42	05/31/90	08:59	0.13	1976.374	7.868	0.017	47.70	
DH42	06/06/90	09:37	0.13	1982.401	6.027	0.022	47.83	
DH42	06/14/90	08:46	0.16	1990.365	7.964	0.020	47.99	
DH42	06/20/90	09:35	0.12	1996.399	6.034	0.020	48.11	
DH42	06/28/90	08:55	0.15	2004.372	7.973	0.019	48.26	
DH42	07/17/90	11:08	0.31	2023.464	19.092	0.016	48.57	
DH42	07/25/90	09:40	0.20	2031.403	7.939	0.025	48.77	
DH42	08/01/90	10:20	0.15	2038.431	7.028	0.021	48.92	
DH42	03/28/91	10:06	3.02	2277.421	0.000	0.000	51.94	Some brine may have been left in hole. Sampler still functioning.
DH42	04/10/91	08:46	0.90	2290.365	0.000	0.000	52.84	Partial evacuation.
DH42	04/11/91	08:42	0.50	2291.363	252.932	0.017	53.34	Combined with 3.02 liters from 03/28/91 and 0.90 liters from 04/10/91.
DH42	04/17/91	10:17	0.11	2297.428	6.065	0.018	53.45	
DH42	04/24/91	09:05	0.12	2304.378	6.950	0.017	53.57	
DH42	05/01/91	09:11	0.12	2311.383	7.005	0.017	53.69	
DH42	05/08/91	08:24	0.12	2318.350	6.967	0.017	53.81	
DH42	05/15/91	09:02	0.12	2325.376	7.026	0.017	53.93	
DH42	05/29/91	09:55	0.27	2339.413	14.037	0.019	54.20	
DH42	06/05/91	13:40	0.14	2346.569	7.156	0.020	54.34	
DH42	06/12/91	10:07	0.12	2353.422	6.853	0.018	54.46	
DH42	06/19/91	13:35	0.13	2360.566	7.144	0.018	54.59	
DH42	06/26/91	09:10	0.12	2367.382	6.816	0.018	54.71	
DH42	07/11/91	10:49	0.27	2382.451	15.069	0.018	54.98	
DH42	07/17/91	09:22	0.11	2388.390	5.939	0.019	55.09	
DH42	07/30/91	10:15	0.30	2401.427	13.037	0.023	55.39	
DH42	08/08/91	09:10	0.24	2410.382	8.955	0.027	55.63	
DH42	08/14/91	10:33	0.16	2416.440	6.058	0.026	55.79	
DH42	08/21/91	10:45	0.17	2423.448	7.008	0.024	55.96	
DH42	08/28/91	10:10	0.24	2430.424	6.976	0.034	56.20	

TABLE A-2 (Continued)
BRINE ACCUMULATION DATA TABLE
 Data through December 31, 1993

LOCATION	DATE	TIME	LITERS REMOVED	DAYS	DAYS	LITERS PER DAY	CUMULATIVE	REMARKS
				SINCE 1/1/85	USED FOR CALCULATION		LITERS COLLECTED	
DH42	09/04/91	11:10	0.18	2437.465	7.041	0.026	56.38	
DH42	09/11/91	11:40	0.16	2444.486	7.021	0.023	56.54	
DH42	09/18/91	09:10	0.18	2451.382	6.896	0.026	56.72	
DH42	09/25/91	11:52	0.15	2458.494	7.112	0.021	56.87	
DH42	10/02/91	11:00	0.15	2465.458	6.964	0.022	57.02	
DH42	10/16/91	09:15	0.26	2479.385	13.927	0.019	57.28	
DH42	10/23/91	09:31	0.16	2486.397	7.012	0.023	57.44	
DH42	11/06/91	10:03	0.28	2500.419	14.022	0.020	57.72	
DH42	11/13/91	09:35	0.15	2507.399	6.980	0.021	57.87	
DH42	11/20/91	11:20	0.14	2514.472	7.073	0.020	58.01	
DH42	11/27/91	10:05	0.13	2521.420	6.948	0.019	58.14	
DH42	12/04/91	09:52	0.12	2528.411	6.991	0.017	58.26	
DH42	12/11/91	09:35	0.10	2535.399	6.988	0.014	58.36	
DH42	12/18/91	09:15	0.13	2542.385	6.986	0.019	58.49	
DH42	12/23/91	08:40	0.10	2547.361	4.976	0.020	58.59	
DH42	01/08/92	09:50	0.31	2563.410	16.049	0.019	58.90	
DH42	01/15/92	09:40	0.11	2570.403	6.993	0.016	59.01	
DH42	01/22/92	08:35	0.16	2577.358	6.955	0.023	59.17	
DH42	01/29/92	09:53	0.17	2584.412	7.054	0.024	59.34	
DH42	02/12/92	08:49	0.26	2598.367	13.955	0.019	59.60	
DH42	02/19/92	09:18	0.10	2605.388	7.021	0.014	59.70	
DH42	02/26/92	09:35	0.17	2612.399	7.011	0.024	59.87	
DH42	03/11/92	09:30	0.23	2626.396	13.997	0.016	60.10	
DH42	03/18/92	09:52	0.13	2633.411	7.015	0.019	60.23	
DH42	03/25/92	10:25	0.39	2640.434	7.023	0.056	60.62	
DH42	04/01/92	09:10	0.13	2647.382	6.948	0.019	60.75	
DH42	04/07/92	09:13	0.09	2653.384	6.002	0.015	60.84	
DH42	04/15/92	09:08	0.15	2661.381	7.997	0.019	60.99	
DH42	04/22/92	09:30	0.13	2668.396	7.015	0.019	61.12	
DH42	05/06/92	11:15	0.06	2682.469	14.073	0.004	61.18	Hole examined, no brine left in hole.
DH42	05/13/92	13:47	0.19	2689.574	7.105	0.027	61.37	
DH42	05/21/92	10:29	0.26	2697.437	7.863	0.033	61.63	
DH42	05/27/92	09:10	0.12	2703.382	5.945	0.020	61.75	
DH42	06/09/92	09:10	0.22	2716.382	13.000	0.017	61.97	
DH42	06/18/92	09:55	0.09	2725.413	9.031	0.010	62.06	
DH42	06/25/92	09:45	0.17	2732.406	6.993	0.024	62.23	
DH42	07/01/92	09:15	0.09	2738.385	5.979	0.015	62.32	
DH42	07/08/92	09:25	0.12	2745.392	7.007	0.017	62.44	
DH42	07/15/92	09:18	0.12	2752.388	6.996	0.017	62.56	
DH42	07/22/92	09:10	0.12	2759.382	6.994	0.017	62.68	
DH42	07/29/92	09:51	0.14	2766.410	7.028	0.020	62.82	
DH42	08/04/92	09:37	0.10	2772.401	5.991	0.017	62.92	
DH42	08/18/92	09:54	0.23	2786.413	14.012	0.016	63.15	
DH42	09/02/92	09:53	0.23	2801.412	14.999	0.015	63.38	
DH42	09/09/92	10:00	0.16	2808.417	7.005	0.023	63.54	
DH42	09/17/92	09:10	0.08	2816.382	7.965	0.010	63.62	
DH42	09/23/92	10:04	0.12	2822.419	6.037	0.020	63.74	

TABLE A-2 (Continued)
BRINE ACCUMULATION DATA TABLE
 Data through December 31, 1993

LOCATION	DATE	TIME	LITERS REMOVED	DAYS	DAYS	LITERS PER DAY	CUMULATIVE	REMARKS
				SINCE 1/1/85	USED FOR CALCULATION		LITERS COLLECTED	
DH42	09/30/92	11:05	0.10	2829.462	7.043	0.014	63.84	
DH42	10/12/92	12:40	0.10	2841.528	12.066	0.008	63.94	
DH42	10/21/92	13:05	0.28	2850.545	9.017	0.031	64.22	
DH42	10/28/92	09:15	0.13	2857.385	6.840	0.019	64.35	
DH42	11/11/92	09:35	0.20	2871.399	14.014	0.014	64.55	
DH42	11/18/92	13:11	0.10	2878.549	7.150	0.014	64.65	
DH42	11/25/92	09:35	0.10	2885.399	6.850	0.015	64.75	
DH42	12/09/92	12:35	0.27	2899.524	14.125	0.019	65.02	
DH42	12/16/92	10:15	0.15	2906.427	6.903	0.022	65.17	
DH42	01/07/93	08:35	0.07	2928.358	21.931	0.003	65.24	
DH42	01/13/93	09:48	0.22	2934.408	6.050	0.036	65.46	
DH42	01/28/93	10:20	0.09	2949.431	15.023	0.006	65.55	
DH42	02/11/93	09:45	0.02	2963.406	13.975	0.001	65.57	
DH42	02/26/93	10:30	0.13	2978.438	15.032	0.009	65.70	
DH42	03/10/93	10:16	0.26	2990.428	11.990	0.022	65.96	
DH42	03/19/93	09:40	0.00	2999.403	8.975	0.000	65.96	
DH42	03/25/93	10:10	0.05	3005.424	6.021	0.008	66.01	
DH42	03/31/93	12:45	0.22	3011.531	6.107	0.036	66.23	
DH42	04/28/93	09:00	0.23	3039.375	27.844	0.008	66.46	
DH42	06/16/93	11:35	0.16	3088.483	49.108	0.003	66.62	
DH42	08/18/93	10:30	0.35	3151.438	0.000	0.000	66.97	Partial evacuation. Unable to sample since 06-16-93.
DH42	08/20/93	09:49	0.35	3153.409	64.926	0.011	67.32	Combine with 0.35 liters from 08-18-93.
DH42	11/09/93	10:37	0.34	3234.442	0.000	0.000	67.66	Partial evacuation.
DH42	11/12/93	10:24	0.65	3237.433	84.024	0.012	68.31	Used bailer. Combine with 0.34 liters from 11-09-93.
DH42A	12/30/84	00:00	NA	0.000	0.000	0.000	0.00	Approximate date this part of Room G excavated.
DH42A	01/25/85	00:00	NA	24.000	0.000	0.000	0.00	Downhole drilled (re-drill of DH42) to recover core from 20 to 40 ft.
DH42A	01/28/85	09:00	NA	27.375	0.000	0.000	0.00	Brine in hole.
DH42A	02/05/85	11:15	00.85	35.469	37.469	0.023	0.85	First time collected.
DH42A	02/11/85	11:00	00.99	41.458	5.989	0.165	1.84	
DH42A	02/19/85	12:10	01.45	49.507	8.049	0.180	3.29	
DH42A	02/26/85	10:45	01.18	56.448	6.941	0.170	4.47	
DH42A	03/05/85	10:00	01.24	63.417	6.969	0.178	5.71	
DH42A	03/12/85	10:20	01.29	70.431	7.014	0.184	7.00	
DH42A	03/20/85	11:00	01.45	78.458	8.027	0.181	8.45	
DH42A	03/26/85	10:10	01.07	84.424	5.966	0.179	9.52	
DH42A	04/02/85	10:45	01.15	91.448	7.024	0.164	10.67	
DH42A	04/10/85	10:45	01.45	99.448	8.000	0.181	12.12	
DH42A	04/17/85	13:30	01.32	106.563	7.115	0.186	13.44	
DH42A	04/23/85	13:23	01.07	112.558	5.995	0.178	14.51	
DH42A	04/30/85	10:23	01.35	119.433	6.875	0.196	15.86	
DH42A	05/07/85	09:23	01.39	126.391	6.958	0.200	17.25	

TABLE A-2 (Continued)
BRINE ACCUMULATION DATA TABLE
 Data through December 31, 1993

LOCATION	DATE	TIME	LITERS REMOVED	DAYS	DAYS	LITERS PER DAY	CUMULATIVE	REMARKS
				SINCE 1/1/85	USED FOR CALCULATION		LITERS COLLECTED	
DH42A	05/14/85	10:25	01.34	133.434	7.043	0.190	18.59	
DH42A	05/21/85	10:14	01.29	140.426	6.992	0.184	19.88	
DH42A	05/29/85	10:30	01.28	148.438	8.012	0.160	21.16	
DH42A	06/04/85	10:50	01.03	154.451	6.013	0.171	22.19	
DH42A	06/11/85	10:15	01.19	161.427	6.976	0.171	23.38	
DH42A	06/18/85	09:51	01.18	168.410	6.983	0.169	24.56	
DH42A	06/25/85	11:05	01.16	175.462	7.052	0.164	25.72	
DH42A	07/02/85	11:00	01.12	182.458	6.996	0.160	26.84	
DH42A	07/09/85	10:25	01.12	189.434	6.976	0.161	27.96	Gas effervescing from sample.
DH42A	07/16/85	11:10	01.11	196.465	7.031	0.158	29.07	Brine effervesces.
DH42A	07/24/85	10:25	01.23	204.434	7.969	0.154	30.30	
DH42A	07/30/85	09:54	00.94	210.413	5.979	0.157	31.24	
DH42A	08/06/85	10:10	01.05	217.424	7.011	0.150	32.29	
DH42A	08/14/85	10:33	01.11	225.440	8.016	0.138	33.40	
DH42A	08/20/85	10:14	00.92	231.426	5.986	0.154	34.32	
DH42A	08/28/85	09:40	01.17	239.403	7.977	0.147	35.49	
DH42A	09/04/85	10:10	00.99	246.424	7.021	0.141	36.48	
DH42A	09/10/85	09:55	00.83	252.413	5.989	0.139	37.31	
DH42A	09/17/85	09:25	00.92	259.392	6.979	0.132	38.23	
DH42A	09/24/85	09:25	00.94	266.392	7.000	0.134	39.17	
DH42A	10/01/85	09:40	00.93	273.403	7.011	0.133	40.10	
DH42A	10/08/85	10:24	00.96	280.433	7.030	0.137	41.06	
DH42A	10/15/85	10:15	00.81	287.427	6.994	0.116	41.87	
DH42A	10/23/85	10:10	01.02	295.424	7.997	0.128	42.89	
DH42A	10/29/85	09:20	00.75	301.389	5.965	0.126	43.64	
DH42A	11/05/85	09:00	00.86	308.375	6.986	0.123	44.50	
DH42A	11/13/85	09:44	01.03	316.406	8.031	0.128	45.53	
DH42A	11/21/85	10:50	00.94	324.451	8.045	0.117	46.47	
DH42A	11/26/85	10:55	00.61	329.455	5.004	0.122	47.08	
DH42A	12/03/85	13:05	00.78	336.545	7.090	0.110	47.86	Sample for chemistry analysis, #1.
DH42A	12/10/85	12:50	00.86	343.535	6.990	0.123	48.72	
DH42A	01/23/86	11:40	05.13	387.486	43.951	0.117	53.85	Entry restricted since 12/10/85 due to mining activities.
DH42A	01/31/86	12:00	00.92	395.500	8.014	0.115	54.77	
DH42A	02/12/86	10:40	01.36	407.444	11.944	0.114	56.13	
DH42A	02/19/86	11:15	00.80	414.469	7.025	0.114	56.93	
DH42A	02/28/86	12:55	00.90	423.538	9.069	0.099	57.83	
DH42A	03/06/86	10:25	00.70	429.434	5.896	0.119	58.53	
DH42A	03/13/86	09:48	00.73	436.408	6.974	0.105	59.26	
DH42A	03/26/86	09:40	01.39	449.403	12.995	0.107	60.65	
DH42A	04/02/86	09:20	00.80	456.389	6.986	0.115	61.45	
DH42A	04/08/86	09:28	00.63	462.394	6.005	0.105	62.08	
DH42A	04/16/86	11:50	00.89	470.493	8.099	0.110	62.97	
DH42A	04/24/86	09:50	00.67	478.410	7.917	0.085	63.64	
DH42A	04/30/86	10:36	00.76	484.442	6.032	0.126	64.40	
DH42A	05/06/86	10:00	00.55	490.417	5.975	0.092	64.95	
DH42A	05/13/86	10:00	00.73	497.417	7.000	0.104	65.68	

TABLE A-2 (Continued)
BRINE ACCUMULATION DATA TABLE
 Data through December 31, 1993

LOCATION	DATE	TIME	LITERS REMOVED	DAYS SINCE 1/1/85	DAYS USED FOR CALCULATION	LITERS PER DAY	CUMULATIVE LITERS COLLECTED	REMARKS
DH42A	05/20/86	11:00	00.70	504.458	7.041	0.099	66.38	
DH42A	05/27/86	15:35	00.65	511.649	7.191	0.090	67.03	
DH42A	06/03/86	09:50	00.66	518.410	6.761	0.098	67.69	
DH42A	06/10/86	11:15	00.54	525.469	7.059	0.076	68.23	
DH42A	06/17/86	10:31	00.65	532.438	6.969	0.093	68.88	Sample for brine chemistry, #21.
DH42A	06/24/86	10:45	00.63	539.448	7.010	0.090	69.51	
DH42A	07/01/86	13:50	00.71	546.576	7.128	0.100	70.22	
DH42A	07/08/86	10:25	00.63	553.434	6.858	0.092	70.85	
DH42A	07/16/86	10:00	00.66	561.417	7.983	0.083	71.51	
DH42A	07/22/86	09:48	00.61	567.408	5.991	0.102	72.12	
DH42A	07/29/86	10:25	00.71	574.434	7.026	0.101	72.83	
DH42A	08/05/86	10:55	00.66	581.455	7.021	0.094	73.49	
DH42A	08/12/86	10:23	00.63	588.433	6.978	0.090	74.12	
DH42A	08/19/86	11:22	00.68	595.474	7.041	0.097	74.80	
DH42A	08/26/86	10:28	00.68	602.436	6.962	0.098	75.48	Static level not measured.
DH42A	09/04/86	10:25	00.71	611.434	8.998	0.079	76.19	Valve broke off and left in hole after collecting most of brine. Some brine left in hole.
DH42A	09/09/86	09:40	00.07	616.403	4.969	0.014	76.26	Bottom obstructed by object in hole. Sample #23.
DH42A	09/16/86	09:59	00.95	623.416	7.013	0.135	77.21	
DH42A	09/23/86	10:02	00.60	630.418	7.002	0.086	77.81	
DH42A	10/01/86	11:57	00.43	638.498	8.080	0.053	78.24	
DH42A	10/08/86	10:55	00.81	645.455	6.957	0.116	79.05	
DH42A	10/14/86	11:24	00.56	651.475	6.020	0.093	79.61	
DH42A	11/05/86	11:04	1.94	673.461	21.986	0.088	81.55	
DH42A	11/20/86	12:08	01.40	688.506	15.045	0.093	82.95	
DH42A	12/31/86	11:30	02.91	729.479	40.973	0.071	85.86	0.99 liters for sample, pH 5.86.
DH42A	02/03/87	12:35	03.15	763.524	34.045	0.093	89.01	
DH42A	03/06/87	10:45	2.61	794.448	30.924	0.084	91.62	
DH42A	03/30/87	10:56	2.52	818.456	24.008	0.105	94.14	
DH42A	05/07/87	11:10	3.17	856.465	38.009	0.083	97.31	
DH42A	06/17/87	10:30	2.94	897.438	0.000	0.000	100.25	Samples removed for chemistry. #113A, #113B, #115A, #115B, #118A, #118B. Approximately 0.01 liter spilled. Some brine left in hole, no calculation.
DH42A	06/18/87	11:54	0.11	898.496	42.031	0.073	100.36	Calculated using 3.05 liters (2.94 liters from 6/17/87 plus 0.11 liters from 6/18/87).
DH42A	07/28/87	11:03	3.07	938.460	39.964	0.077	103.43	
DH42A	09/01/87	10:08	2.69	973.422	34.962	0.077	106.12	Collected for chemistry, sample #154 A&B and Sample #150 A&B. Samples effervesce.
DH42A	10/20/87	11:28	3.73	1022.478	49.056	0.076	109.85	
DH42A	11/19/87	10:55	2.17	1052.455	29.977	0.072	112.02	Collected for chemistry, sample #228 & #233.
DH42A	01/04/88	11:25	3.28	1098.476	46.021	0.071	115.30	
DH42A	02/08/88	11:10	2.47	1133.465	34.989	0.071	117.77	Collected for chemistry, sample #250, #251,

TABLE A-2 (Continued)
BRINE ACCUMULATION DATA TABLE
 Data through December 31, 1993

LOCATION	DATE	TIME	LITERS REMOVED	DAYS SINCE 1/1/85	DAYS USED FOR CALCULATION	LITERS PER DAY	CUMULATIVE LITERS COLLECTED	REMARKS
DH42A	03/29/88	11:15	3.57	1183.469	50.004	0.071	121.34	#252, #253, & #254. Collected for chemistry, sample #316 - #322.
DH42A	05/05/88	09:00	2.38	1220.375	36.906	0.064	123.72	Sampled for SNL/NM PA.
DH42A	05/12/88	09:40	0.50	1227.403	7.028	0.071	124.22	Sampled for SNL/NM PA.
DH42A	07/12/88	08:30	4.06	1288.354	60.951	0.067	128.28	Collected for chemistry, sample #407 - #414.
DH42A	07/28/88	10:15	1.25	1304.427	16.073	0.078	129.53	Sampled for SNL/NM PA.
DH42A	09/14/88	08:45	3.00	1352.365	47.938	0.063	132.53	
DH42A	09/27/88	10:10	1.07	1365.424	13.059	0.082	133.60	Collected for chemistry, sample #528 & #529.
DH42A	12/13/88	09:35	7.95	1442.399	76.975	0.103	141.55	Collected for chemistry, sample #618 - #627.
DH42A	03/15/89	10:00	5.82	1534.417	92.018	0.063	147.37	Sample saved for chemistry, sample #714 - 721.
DH42A	04/06/89	10:15	1.44	1556.427	22.010	0.065	148.81	
DH42A	04/20/89	09:00	0.75	1570.375	13.948	0.054	149.56	
DH42A	05/17/89	09:45	1.91	1597.406	27.031	0.071	151.47	
DH42A	06/06/89	09:45	1.30	1617.406	20.000	0.065	152.77	Sample saved for chemistry.
DH42A	06/29/89	10:15	1.35	1640.427	23.021	0.059	154.12	
DH42A	07/25/89	10:05	1.51	1666.420	25.993	0.058	155.63	Sample saved for SNL/NM brine study.
DH42A	08/16/89	09:31	1.48	1688.397	21.977	0.067	157.11	Sample saved for SNL/NM brine study.
DH42A	09/12/89	08:50	1.63	1715.368	26.971	0.060	158.74	Sample saved for chemistry.
DH42A	12/13/89	09:20	5.28	1807.389	92.021	0.057	164.02	Sample saved for chemistry, #897.
DH42A	01/10/90	09:36	1.95	1835.400	28.011	0.070	165.97	
DH42A	01/24/90	09:52	0.75	1849.411	14.011	0.054	166.72	
DH42A	02/07/90	10:20	0.95	1863.431	14.020	0.068	167.67	
DH42A	02/21/90	09:56	0.81	1877.414	13.983	0.058	168.48	
DH42A	03/05/90	08:47	0.68	1889.366	11.952	0.057	169.16	
DH42A	03/13/90	11:36	NA	1897.483	0.000	0.000	169.16	Installed sampler.
DH42A	03/19/90	11:07	0.51	1903.463	0.000	0.000	169.67	Partial evacuation.
DH42A	03/21/90	10:21	0.28	1905.431	16.065	0.049	169.95	Combined with 0.51 liters from 03/19/90. Used 0.79 liters for calculation.
DH42A	04/04/90	09:14	0.60	1919.385	13.954	0.043	170.55	
DH42A	04/10/90	08:40	0.58	1925.361	5.976	0.097	171.13	
DH42A	04/17/90	10:19	0.38	1932.430	7.069	0.054	171.51	
DH42A	04/24/90	09:18	0.42	1939.388	6.958	0.060	171.93	
DH42A	05/02/90	10:32	0.51	1947.439	8.051	0.063	172.44	
DH42A	05/09/90	08:48	0.39	1954.367	6.928	0.056	172.83	
DH42A	05/16/90	09:07	0.43	1961.380	7.013	0.061	173.26	
DH42A	05/23/90	12:08	0.40	1968.506	7.126	0.056	173.66	
DH42A	05/31/90	08:47	0.46	1976.366	7.860	0.059	174.12	
DH42A	06/06/90	09:30	0.34	1982.396	6.030	0.056	174.46	
DH42A	06/14/90	08:38	0.39	1990.360	7.964	0.049	174.85	
DH42A	06/20/90	09:33	0.45	1996.398	6.038	0.075	175.30	
DH42A	06/28/90	08:50	0.45	2004.368	7.970	0.056	175.75	
DH42A	07/17/90	11:04	0.56	2023.461	0.000	0.000	176.31	Partial evacuation.

TABLE A-2 (Continued)
BRINE ACCUMULATION DATA TABLE
 Data through December 31, 1993

LOCATION	DATE	TIME	LITERS REMOVED	DAYS	DAYS	LITERS PER DAY	CUMULATIVE	REMARKS
				SINCE 1/1/85	USED FOR CALCULATION		LITERS COLLECTED	
DH42A	07/18/90	10:30	0.48	2024.438	20.070	0.052	176.79	Combined with 0.56 liters from 07/17/90. Used 1.04 liters for calculation.
DH42A	07/25/90	09:37	0.43	2031.401	6.963	0.062	177.22	
DH42A	08/01/90	10:18	0.50	2038.429	7.028	0.071	177.72	
DH42A	03/28/91	09:40	18.89	2277.403	0.000	0.000	196.61	Some brine may have been left in hole.
DH42A	04/10/91	8:46	0.89	2290.338	0.000	0.000	197.50	Partial evacuation.
DH42A	04/11/91	08:30	0.14	2291.354	252.925	0.079	197.64	Combined with 18.89 liters from 03/28/91 and 0.89 liters from 04/10/91.
DH42A	04/17/91	10:15	0.35	2297.427	6.073	0.058	197.99	
DH42A	04/24/91	09:05	0.40	2304.378	6.951	0.058	198.39	
DH42A	05/01/91	09:10	0.40	2311.382	7.004	0.057	198.79	
DH42A	05/08/91	08:19	0.34	2318.347	6.965	0.049	199.13	
DH42A	05/15/91	08:58	0.40	2325.374	7.027	0.057	199.53	
DH42A	05/29/91	09:56	0.65	2339.414	14.040	0.046	200.18	
DH42A	06/05/91	13:35	0.47	2346.566	7.152	0.066	200.65	
DH42A	06/12/91	10:00	0.53	2353.417	6.851	0.077	201.18	
DH42A	06/19/91	13:30	0.41	2360.563	7.146	0.057	201.59	
DH42A	06/26/91	09:16	0.39	2367.386	6.823	0.057	201.98	
DH42A	07/11/91	10:45	0.55	2382.448	15.062	0.037	202.53	
DH42A	07/17/91	09:20	0.58	2388.389	0.000	0.000	203.11	Partial evacuation.
DH42A	07/18/91	09:50	0.11	2389.410	0.000	0.000	203.22	Partial evacuation.
DH42A	07/30/91	10:10	0.42	2401.424	18.976	0.058	203.64	Combined with 0.58 liters from 07/17 and 0.11 liters from 07/18/91.
DH42A	08/08/91	09:05	0.47	2410.378	8.954	0.052	204.11	
DH42A	08/14/91	10:30	0.45	2416.438	6.060	0.074	204.56	
DH42A	08/21/91	10:40	0.38	2423.444	7.006	0.054	204.94	
DH42A	08/28/91	09:58	0.39	2430.415	6.971	0.056	205.33	
DH42A	09/04/91	11:00	0.53	2437.458	7.043	0.075	205.86	
DH42A	09/11/91	11:35	0.39	2444.483	7.025	0.056	206.25	
DH42A	09/18/91	09:00	0.40	2451.375	6.892	0.058	206.65	
DH42A	09/25/91	11:50	0.31	2458.493	7.118	0.044	206.96	
DH42A	10/02/91	11:07	0.41	2465.463	6.970	0.059	207.37	
DH42A	10/16/91	09:10	0.43	2479.382	13.919	0.031	207.80	
DH42A	10/23/91	09:30	0.43	2486.396	7.014	0.061	208.23	
DH42A	10/31/91	09:40	0.50	2494.403	8.007	0.062	208.73	
DH42A	11/06/91	10:00	0.36	2500.417	6.014	0.060	209.09	
DH42A	11/13/91	09:39	0.28	2507.402	6.985	0.040	209.37	
DH42A	11/20/91	11:24	0.44	2514.475	7.073	0.062	209.81	
DH42A	11/27/91	10:05	0.33	2521.420	6.945	0.048	210.14	
DH42A	12/04/91	09:52	0.40	2528.411	6.991	0.057	210.54	
DH42A	12/11/91	09:30	0.38	2535.396	6.985	0.054	210.92	
DH42A	12/18/91	09:10	0.41	2542.382	6.986	0.059	211.33	
DH42A	12/23/91	08:35	0.37	2547.358	4.976	0.074	211.70	
DH42A	01/08/92	09:45	0.22	2563.406	16.048	0.014	211.92	
DH42A	01/15/92	09:44	0.37	2570.406	7.000	0.053	212.29	
DH42A	01/22/92	08:30	0.25	2577.354	6.948	0.036	212.54	
DH42A	01/29/92	09:50	0.27	2584.410	7.056	0.038	212.81	

TABLE A-2 (Continued)
BRINE ACCUMULATION DATA TABLE
 Data through December 31, 1993

LOCATION	DATE	TIME	LITERS REMOVED	DAYS SINCE 1/1/85	DAYS USED FOR CALCULATION	LITERS PER DAY	CUMULATIVE LITERS COLLECTED	REMARKS
DH42A	02/12/92	08:40	0.40	2598.361	13.951	0.029	213.21	
DH42A	02/19/92	09:21	0.37	2605.390	7.029	0.053	213.58	
DH42A	02/26/92	09:35	0.40	2612.399	7.009	0.057	213.98	
DH42A	03/11/92	09:30	0.48	2626.396	13.997	0.034	214.46	
DH42A	03/18/92	09:51	0.47	2633.410	7.014	0.067	214.93	
DH42A	03/25/92	10:23	0.13	2640.433	7.023	0.019	215.06	
DH42A	04/01/92	09:00	0.45	2647.375	6.942	0.065	215.51	
DH42A	04/07/92	09:10	0.40	2653.382	6.007	0.067	215.91	
DH42A	04/15/92	09:00	0.48	2661.375	7.993	0.060	216.39	
DH42A	04/22/92	09:30	0.44	2668.396	7.021	0.063	216.83	
DH42A	05/06/92	11:10	0.45	2682.465	0.000	0.000	217.28	Partial evacuation, some brine left in hole.
DH42A	05/07/92	09:30	0.07	2683.396	15.000	0.035	217.35	Combine with 0.45 liters removed 05/06/92 for total volume.
DH42A	05/13/92	13:45	0.40	2689.573	6.177	0.065	217.75	
DH42A	05/21/92	10:22	0.43	2697.432	7.859	0.055	218.18	
DH42A	05/27/92	09:05	0.35	2703.378	5.946	0.059	218.53	
DH42A	06/09/92	09:00	0.44	2716.375	12.997	0.034	218.97	
DH42A	06/18/92	09:45	0.29	2725.406	9.031	0.032	219.26	
DH42A	06/25/92	09:40	0.46	2732.403	6.997	0.066	219.72	
DH42A	07/01/92	09:10	0.58	2738.382	5.979	0.097	220.30	
DH42A	07/08/92	09:22	0.44	2745.390	7.008	0.063	220.74	
DH42A	07/15/92	09:14	0.40	2752.385	6.995	0.057	221.14	
DH42A	07/22/92	09:00	0.46	2759.375	6.990	0.066	221.60	
DH42A	07/29/92	09:48	0.48	2766.408	7.033	0.068	222.08	
DH42A	08/04/92	09:34	0.41	2772.399	5.991	0.068	222.49	
DH42A	08/18/92	09:56	0.67	2786.414	14.015	0.048	223.16	
DH42A	09/02/92	09:50	0.59	2801.410	14.996	0.039	223.75	
DH42A	09/09/92	10:03	2.38	2808.419	7.009	0.340	226.13	
DH42A	09/17/92	09:00	0.28	2816.375	7.956	0.035	226.41	
DH42A	09/23/92	10:03	0.43	2822.419	6.044	0.071	226.84	
DH42A	09/30/92	11:00	0.49	2829.458	7.039	0.070	227.33	
DH42A	10/12/92	12:35	0.34	2841.524	12.066	0.028	227.67	
DH42A	10/21/92	13:03	0.69	2850.544	9.020	0.076	228.36	
DH42A	10/28/92	09:10	0.66	2857.382	6.838	0.097	229.02	
DH42A	11/11/92	09:30	0.90	2871.396	14.014	0.064	229.92	
DH42A	11/18/92	13:09	0.30	2878.548	7.152	0.042	230.22	
DH42A	11/25/92	09:30	0.39	2885.396	6.848	0.057	230.61	
DH42A	12/09/92	12:30	0.65	2899.521	14.125	0.046	231.26	
DH42A	12/16/92	10:15	0.46	2906.427	6.906	0.067	231.72	
DH42A	01/07/93	08:30	0.55	2928.354	21.927	0.025	232.27	
DH42A	01/13/93	09:45	0.69	2934.406	6.052	0.114	232.96	
DH42A	01/28/93	10:10	0.75	2949.424	15.018	0.050	233.71	
DH42A	02/11/93	09:40	0.63	2963.403	13.979	0.045	234.34	
DH42A	02/26/93	10:15	1.25	2978.427	15.024	0.083	235.59	
DH42A	03/10/93	10:10	0.67	2990.424	11.997	0.056	236.26	
DH42A	03/19/93	09:37	0.43	2999.401	8.977	0.048	236.69	

TABLE A-2 (Continued)
BRINE ACCUMULATION DATA TABLE
 Data through December 31, 1993

LOCATION	DATE	TIME	LITERS REMOVED	DAYS	DAYS	LITERS PER DAY	CUMULATIVE	REMARKS
				SINCE 1/1/85	USED FOR CALCULATION		LITERS COLLECTED	
DH42A	03/25/93	09:50	0.28	3005.410	6.009	0.047	236.97	
DH42A	03/31/93	12:35	0.40	3011.524	6.114	0.065	237.37	
DH42A	04/28/93	08:45	1.26	3039.365	27.841	0.045	238.63	Used bailer, hole left dry.
DH42A	06/16/93	11:50	1.85	3088.493	49.128	0.038	240.48	Used bailer.
DH42A	08/18/93	10:48	3.25	3151.450	0.000	0.000	243.73	Partial evacuation. Unable to sample since 06-16-93.
DH42A	08/20/93	09:36	0.50	3153.400	64.907	0.058	244.23	Combine with 3.25 liters from 08-18-93.
DH42A	11/09/93	10:33	0.38	3234.440	0.000	0.000	244.61	Partial evacuation.
DH42A	11/12/93	10:21	0.58	3237.431	84.031	0.011	245.19	Used bailer. Combine with 0.38 liter from 11-09-93.
DHP402A	10/29/86	00:00	NA	0.000	0.000	0.000	0.00	Drift excavated at S1950/E1320.
DHP402A	12/05/86	00:00	NA	703.000	37.000	0.000	0.00	Downhole completed.
DHP402A	03/06/87	09:40	0.14	794.403	0.000	0.000	0.14	First time sampled.
DHP402A	03/30/87	09:15	0.00	818.385	0.000	0.000	0.14	
DHP402A	04/22/87	11:24	0.03	841.475	138.475	0.001	0.17	Bailer stuck in hole. Hole appears offset or blocked at 45 feet. There may be a rock bolt or piece of rod in the hole.
DHP402A	07/08/87	00:00	NA	918.000	0.000	0.000	0.17	Horizontal pilot hole for Room 7 of the first Waste Storage Panel started just north of this location, drilled with brine.
DHP402A	07/16/87	09:20	0.00	926.389	0.000	0.000	0.17	Hole entirely filled with brine from drilling the pilot /gas release hole for the last room of the first panel.
DHP402A	07/28/87	10:20	17.50	938.431	0.000	0.000	17.67	Removed 17.5 liters of brine from hole, mostly drilling fluid.
DHP402A	07/29/87	09:10	15.00	939.382	0.000	0.000	32.67	Drilling brine removed from hole. Partial evacuation, brine left in hole.
DHP402A	08/16/87	00:00	NA	957.000	0.000	0.000	32.67	Brine from the AIS sump spread in Panel 1 to assist in the reconstitution of loose muck on the floor.
DHP402A	08/20/87	00:00	NA	961.000	0.000	0.000	32.67	Brine from the AIS sump spread in Panel 1 to assist in the reconstitution of loose muck on the floor.
DHP402A	10/01/87	00:00	NA	1003.000	0.000	0.000	32.67	Approximate date the salt muck stockpile was placed at the east end of S1950, covering the collar of this hole.
DHP402A	07/12/88	13:50		1288.576	0.000	0.000	32.67	Muck piled over hole, could not collect.
DHP402A	08/19/88	10:00	57.25	1326.417	484.942	0.185	89.92	Collected for chemistry, sample #492 - #497. Used 72.25 liters for calculation (15.0 on 7/29 + 57.25 on 8/19).
DHP402A	08/30/88	11:00	42.75	1337.458	11.041	3.872	132.67	Depth of water 28.8 feet below floor. Bottom of hole at 44.3 feet. 5.7 feet of salt on bottom of hole.
DHP402A	09/15/88	10:00	0.24	1353.417	0.000	0.000	132.91	Not fully evacuated. Don't use for calculation. Sampled for bacteriology.

TABLE A-2 (Continued)
BRINE ACCUMULATION DATA TABLE
 Data through December 31, 1993

LOCATION	DATE	TIME	LITERS REMOVED	DAYS	DAYS	LITERS PER DAY	CUMULATIVE	REMARKS
				SINCE 1/1/85	USED FOR CALCULATION		LITERS COLLECTED	
DHP402A	09/22/88	09:00	63.75	1360.375	22.917	2.792	196.66	Hole evacuated to 44.2' level. Chemistry samples #498 - #503.
DHP402A	10/18/88	13:45	45	1386.573	26.198	1.718	241.66	Some moisture could have entered hole due to water spread for dust control
DHP402A	11/15/88	10:30	40.65	1414.438	27.865	1.459	282.31	Evacuated to 43.75 foot level. Obstruction near bottom of hole prevents additional evacuation.
DHP402A	12/13/88	10:50	6.0	1442.451	0.000	0.000	288.31	Collected for chemistry, sample #606 - #617. Not fully evacuated, some brine left in hole.
DHP402A	12/29/88	12:00	43.60	1458.500	44.062	1.126	331.91	Used 49.6 liters for calculation (6.0 on 12/13 + 43.6 on 12/29).
DHP402A	01/04/89	13:30	13.5	1464.563	6.063	2.227	345.41	Complete evacuation to 43.3 ft. level. Strong odor of diesel from hole and bailer.
DHP402A	01/20/89	10:30	19	1480.438	15.875	1.197	364.41	Volume removed includes 2.5 gallons of brine introduced to hole by Intera.
DHP402A	02/28/89	11:50	12.1	1519.493	39.055	0.310	376.51	Hole open to 44.2 feet.
DHP402A	04/06/89	13:30	1.19	1556.563	37.070	0.032	377.70	Sample removed from above packer.
DHP402A	04/20/89	13:05	NA	1570.545	0.000	0.000	377.70	Level measured at 33.1 feet.
DHP402A	04/26/89	10:30	NA	1576.438	0.000	0.000	377.70	Level of brine at 27.2 feet.
DHP402A	04/27/89	10:00	49.00	1577.417	20.854	2.350	426.70	Hole bottom measured at 44.3 feet.
DHP402A	05/17/89	09:00	33	1597.375	19.958	1.653	459.70	Fluid level at 44.6 feet.
DHP402A	06/20/89	10:00	NA	1631.417	0.000	0.000	459.70	Fluid measured at 39.8 feet. Hole not evacuated.
DHP402A	06/29/89	09:00	NA	1640.375	0.000	0.000	459.70	Measured hole fluid level at 37.6 feet.
DHP402A	07/24/89	09:50	24	1665.410	68.035	0.353	483.70	Sample saved for Intera brine study. Hole pumped to fluid level of 41.1 feet.
DHP402A	08/16/89	09:00	NA	1688.375	0.000	0.000	483.70	Sample not obtained. Fluid level at 36.5 feet.
DHP402A	08/23/89	11:45	NA	1695.490	0.000	0.000	483.70	Observed fluid level at 35.4 feet. Not sampled.
DHP402A	09/12/89	12:30	6.30	1715.521	50.111	0.126	490.00	Partial collection for chemistry.
DHP402A	10/02/89	11:00	25.5	1735.458	19.937	1.279	515.50	Sample saved for Intera brine study.
DHP402A	11/15/89	10:30	16	1779.438	43.980	0.364	531.50	Sample saved for Intera brine study.
DHP402A	12/13/89	12:12	15.62	1807.508	28.070	0.556	547.12	Sample saved for chemistry and for Intera brine study, sample #901.
DHP402A	03/22/90	08:53	4.0	1906.370	0.000	0.000	551.12	Hole not completely evacuated.
DHP402A	03/26/90	09:25	7.0	1910.392	0.000	0.000	558.12	Hole not completely evacuated.
DHP402A	05/31/90	10:03	0.0	1976.419	0.000	0.000	558.12	Hole not sampled, water level at 36.0 feet.
DHP402A	06/20/90	10:31	15.0	1996.438	188.930	0.138	573.12	2 liters for BSEP, .25 liters for SNL/NM. Partial evacuation. Combined with 4.0 liters (3/22) and 7.0 liters (3/26).
DHP402A	10/05/90	09:30	2.250	2103.396	0.000	0.000	575.37	Partial evacuation.
DHP402A	11/14/90	10:20	0.0	2143.431	0.000	0.000	575.37	Hole not sampled, water level at 34.2 feet.
DHP402A	12/20/90	10:05	40.7	2179.420	182.982	0.235	616.07	Combined with 2.25 liters from 10/05/90. Used 42.95 liters for calculation.
DHP402A	02/20/91	13:00	2.0	2241.542	0.000	0.000	618.07	Partial evacuation.

TABLE A-2 (Continued)
BRINE ACCUMULATION DATA TABLE
 Data through December 31, 1993

LOCATION	DATE	TIME	LITERS REMOVED	DAYS SINCE 1/1/85	DAYS USED FOR CALCULATION	LITERS PER DAY	CUMULATIVE LITERS COLLECTED	REMARKS
DHP402A	03/11/91	10:45	12.72	2260.448	0.000	0.000	630.79	Partial evacuation. Removed for SNL/NM study.
DHP402A	03/27/91	10:27	5.20	2276.435	97.015	0.205	635.99	Combined with 2.0 liters from 02/20/91 and 12.72 liters from 03/11/91. Sample given to INTERA.
DHP402A	07/11/91	10:00	2.00	2382.417	0.000	0.000	637.99	Partial evacuation.
DHP402A	09/18/91	10:15	0.06	2451.427	0.000	0.000	638.05	Collected over two week period.
DHP402A	09/25/91	12:43	2.0	2458.530	182.095	0.022	640.05	Combined with 2.0 liters from 07/11/91 and 0.06 liters from 09/18/91.
DHP402A	04/16/92	12:15	3.00	2662.510	203.980	0.015	643.05	Saved for BSEP.
DHP402A	08/20/92	09:20	1.00	2788.389	125.879	0.008	644.05	Partial evacuation for BSEP analytical program.
GSEEP	11/21/84			0.000	0.000	0.000	0.00	Approximate date this part of Room G excavated.
GSEEP	08/28/85			239.000	0.000	0.000	0.00	Noticed damp area on floor at this location.
GSEEP	11/12/85	1		315.001	0.000	0.000	0.00	Damp area on floor near S. rib approx. E1140 (45 ft. E. of DH35) and at E1149. Crusted moist area is about 4'x 4', has increased noticeably in size over the last two months.
GSEEP	11/12/85	2		315.001	0.000	0.000	0.00	Damp area covers 16 ft. E-W, 13 ft. N-S across width of Room G. Many weeps on lower 3 ft. of S. rib. Brine is seeping out of air pipe support hole.
GSEEP	11/26/85	12:00	3.00	329.500	14.498	0.207	3.00	First time collection. Dug out salt.
GSEEP	12/03/85	12:00	1.50	336.500	7.000	0.214	4.50	Partial removal. Collected 0.05 liters for chemistry analysis #5.
GSEEP	12/04/85	12:00	1.13	337.500	1.000	1.130	5.63	
GSEEP	12/10/85	12:00	1.80	343.500	6.000	0.300	7.43	
GSEEP	01/23/86	12:00	0.50	387.500	44.000	0.011	7.93	Salt in pool.
GSEEP	01/31/86	12:00	0.94	395.500	8.000	0.118	8.87	
GSEEP	02/12/86	12:00	2.23	407.500	12.000	0.186	11.10	Pumped twice.
GSEEP	02/19/86	12:00	2.14	414.500	7.000	0.306	13.24	
GSEEP	02/28/86	12:00	1.95	423.500	9.000	0.217	15.19	Partial removal. No pump, scooped with beaker.
GSEEP	03/04/86	11:20	2.62	427.472	3.972	0.660	17.81	
GSEEP	03/06/86	10:50	2.07	429.451	1.979	1.046	19.88	
GSEEP	03/13/86	11:46	3.23	436.490	7.039	0.459	23.11	Collected three times.
GSEEP	03/26/86	10:20	3.00	449.431	12.941	0.232	26.11	
GSEEP	04/02/86	10:00	2.68	456.417	6.986	0.384	28.79	
GSEEP	04/08/86	10:00	2.50	462.417	6.000	0.417	31.29	
GSEEP	04/16/86	12:00	2.24	470.500	8.083	0.277	33.53	
GSEEP	04/24/86	10:30	2.35	478.438	7.938	0.296	35.88	
GSEEP	04/30/86	11:00	2.40	484.458	6.020	0.399	38.28	

TABLE A-2 (Continued)
BRINE ACCUMULATION DATA TABLE
 Data through December 31, 1993

LOCATION	DATE	TIME	LITERS REMOVED	DAYS SINCE 1/1/85	DAYS USED FOR CALCULATION	LITERS PER DAY	CUMULATIVE LITERS COLLECTED	REMARKS
GSEEP	05/06/86	10:30	2.49	490.438	5.980	0.416	40.77	
GSEEP	05/13/86	11:20	2.66	497.472	7.034	0.378	43.43	
GSEEP	05/20/86	11:20	2.44	504.472	7.000	0.349	45.87	
GSEEP	05/27/86	15:30	3.11	511.646	7.174	0.434	48.98	
GSEEP	06/03/86	10:40	3.31	518.444	6.798	0.487	52.29	
GSEEP	06/10/86	11:38	3.21	525.485	7.041	0.456	55.50	
GSEEP	06/17/86	11:15	3.11	532.469	6.984	0.445	58.61	Sample for brine chemistry, #20.
GSEEP	06/24/86	11:00	4.60	539.458	6.989	0.658	63.21	Very humid air in workings.
GSEEP	07/01/86	14:00	5.43	546.583	7.125	0.762	68.64	Very humid last week, rain on surface.
GSEEP	07/08/86	10:50	4.14	553.451	6.868	0.603	72.78	
GSEEP	07/16/86	10:50	3.32	561.451	8.000	0.415	76.10	
GSEEP	07/22/86	10:15	2.29	567.427	5.976	0.383	78.39	
GSEEP	07/29/86	10:45	2.68	574.448	7.021	0.382	81.07	
GSEEP	08/05/86	11:20	2.60	581.472	7.024	0.370	83.67	
GSEEP	08/12/86	10:45	3.67	588.448	6.976	0.526	87.34	
GSEEP	08/19/86	11:40	3.90	595.486	7.038	0.554	91.24	
GSEEP	08/26/86	11:00	3.73	602.458	6.972	0.535	94.97	
GSEEP	09/04/86	10:55	5.15	611.455	8.997	0.572	100.12	Last week has been humid and rainy.
GSEEP	09/09/86	10:00	3.70	616.417	4.962	0.746	103.82	
GSEEP	09/16/86	10:25	3.82	623.434	7.017	0.544	107.64	
GSEEP	09/23/86	10:20	4.29	630.431	6.997	0.613	111.93	
GSEEP	10/01/86	12:24	3.70	638.517	8.086	0.458	115.63	
GSEEP	10/08/86	10:45	3.80	645.448	0.000	0.000	119.43	Partial collection.
GSEEP	10/08/86	14:57	1.87	645.623	7.106	0.798	121.30	Second collection for this day. Use $(3.80 + 1.87)/(6.931 + 0.175) = 0.798$ l/day.
GSEEP	10/10/86	09:16	1.24	647.386	1.763	0.703	122.54	
GSEEP	10/14/86	11:10	2.19	651.465	4.079	0.537	124.73	
GSEEP	11/05/86	10:45	4.44	673.448	21.983	0.202	129.17	First time 3.74 liters, second time 0.70 liters.
GSEEP	11/20/86	12:02	3.84	688.501	15.053	0.255	133.01	
GSEEP	12/30/86	12:50	4.44	728.535	40.034	0.111	137.45	
GSEEP	02/03/87	13:45	3.45	763.573	35.038	0.098	140.90	
GSEEP	03/06/87	11:30	3.0	794.479	30.906	0.097	143.90	
GSEEP	03/30/87	11:34	2.51	818.482	24.003	0.105	146.41	
GSEEP	05/07/87	11:48	3.31	856.492	38.010	0.087	149.72	
GSEEP	06/30/87	10:00	12.24	910.417	53.925	0.227	161.96	
GSEEP	07/16/87	10:30	11.66	926.438	16.021	0.728	173.62	
GSEEP	07/23/87	09:20	3.87	933.389	6.951	0.557	177.49	
GSEEP	07/28/87	11:35	2.36	938.483	5.094	0.463	179.85	
GSEEP	08/07/87	09:15	5.33	948.385	9.902	0.538	185.18	
GSEEP	08/12/87	10:12	2.80	953.425	5.040	0.556	187.98	
GSEEP	08/24/87	08:46	6.53	965.365	11.940	0.547	194.51	
GSEEP	09/01/87	11:00	5.26	973.458	8.093	0.650	199.77	Collected for chemistry, sample #164 A&B, #166 A&B, #169 A&B, #165 A&B, #168 A&B.
GSEEP	09/11/87	09:00	5.03	983.375	9.917	0.507	204.80	
GSEEP	09/16/87	09:33	2.42	988.398	5.023	0.482	207.22	
GSEEP	09/25/87	08:55	4.12	997.372	8.974	0.459	211.34	Sump drilled to facilitate accumulation of

TABLE A-2 (Continued)
BRINE ACCUMULATION DATA TABLE
 Data through December 31, 1993

LOCATION	DATE	TIME	LITERS REMOVED	DAYS	DAYS	LITERS PER DAY	CUMULATIVE	REMARKS
				SINCE 1/1/85	USED FOR CALCULATION		LITERS COLLECTED	
								brine.
GSEEP	10/01/87	12:15	2.81	1003.510	6.138	0.458	214.15	
GSEEP	10/08/87	10:25	2.97	1010.434	6.924	0.429	217.12	
GSEEP	10/16/87	10:41	3.37	1018.445	8.011	0.421	220.49	
GSEEP	10/20/87	11:59	2.06	1022.499	4.054	0.508	222.55	
GSEEP	11/12/87	10:41	10.21	1045.445	22.946	0.445	232.76	
GSEEP	11/19/87	11:35	2.90	1052.483	7.038	0.412	235.66	Collected for chemistry, sample #202, #219 & #231.
GSEEP	12/07/87	12:50	7.02	1070.535	18.052	0.389	242.68	Collected for chemistry, sample #239.
GSEEP	01/04/88	12:10	16.11	1098.507	27.972	0.576	258.79	
GSEEP	01/20/88	11:25	8.68	1114.476	15.969	0.544	267.47	
GSEEP	02/08/88	12:15	9.58	1133.510	19.034	0.503	277.05	Collected for chemistry, sample #271, #272, #273, #274, #275, #276, #277, #278, #279, #280, #281, #282, #283, #284, #285, & #286.
GSEEP	02/25/88	10:40	11.87	1150.444	16.934	0.701	288.92	
GSEEP	03/09/88	10:18	7.35	1163.429	12.985	0.566	296.27	
GSEEP	03/17/88	11:20	4.45	1171.472	8.043	0.553	300.72	
GSEEP	03/29/88	11:45	5.42	1183.490	12.018	0.451	306.14	Collected for chemistry, sample #327 - #337.
GSEEP	04/15/88	11:01	7.43	1200.459	16.969	0.438	313.57	
GSEEP	05/05/88	10:10	9.34	1220.424	19.965	0.468	322.91	Sampled for SNL/NM PA.
GSEEP	05/12/88	09:30	3.55	1227.396	6.972	0.509	326.46	Sampled for SNL/NM PA.
GSEEP	06/09/88	08:45	12.00	1255.365	27.969	0.429	338.46	Removed for SNL/NM PA.
GSEEP	06/16/88	09:43	4.13	1262.405	7.040	0.587	342.59	Sampled for SNL/NM PA.
GSEEP	06/30/88	08:30	6.00	1276.354	13.949	0.430	348.59	Sampled for SNL/NM PA.
GSEEP	07/12/88	09:00	6.40	1288.375	12.021	0.532	354.99	Collected for chemistry, sample #437 - #448.
GSEEP	07/28/88	10:30	11.35	1304.438	16.063	0.707	366.34	Sampled for SNL/NM PA.
GSEEP	08/11/88	10:00	12.02	1318.417	13.979	0.860	378.36	Sampled for SNL/NM PA.
GSEEP	08/25/88	09:07	6.72	1332.380	13.963	0.481	385.08	Hole covered with tight fitting brattice cloth. Sampled for SNL/NM PA.
GSEEP	09/08/88	14:48	7.31	1346.617	14.237	0.513	392.39	Sampled for SNL/NM PA.
GSEEP	09/14/88	08:30	3.00	1352.354	5.737	0.523	395.39	
GSEEP	09/27/88	10:50	6.45	1365.451	13.097	0.492	401.84	Collected for chemistry, sample #545 - #556.
GSEEP	10/18/88	10:22	10.20	1386.432	20.981	0.486	412.04	
GSEEP	11/10/88	09:08	12.62	1409.381	22.949	0.550	424.66	Smell of urine in sample and coming from hole.
GSEEP	12/13/88	10:20	17.81	1442.431	33.050	0.539	442.47	Collected for chemistry, sample #564 - #569. Sample effervesces and brine feels warmer than usual.
GSEEP	01/10/89	13:30	17.38	1470.563	28.132	0.618	459.85	Sample saved for SNL/NM brine study.
GSEEP	02/09/89	10:22	19.5	1500.432	29.869	0.653	479.35	Sample saved for SNL/NM brine study.
GSEEP	03/01/89	10:00	3.90	1520.417	19.985	0.195	483.25	Partial collection for Westinghouse.
GSEEP	03/14/89	12:45	19.57	1533.531	13.114	1.492	502.82	Sample saved for chemistry, sample #672 - 683. Add 3.9 liters collected 3/01/90 to 19.57 liters Use 23.47 liters for

TABLE A-2 (Continued)
BRINE ACCUMULATION DATA TABLE
 Data through December 31, 1993

LOCATION	DATE	TIME	LITERS REMOVED	DAYS SINCE 1/1/85	DAYS USED FOR CALCULATION	LITERS PER DAY	CUMULATIVE LITERS COLLECTED	REMARKS
GSEEP	04/06/89	08:56	16.35	1556.372	22.841	0.716	519.17	calculation. 16 liters of sample saved for SNL/NM brine study.
GSEEP	04/20/89	08:45	10.43	1570.365	13.993	0.745	529.60	Sample saved for SNL/NM brine study.
GSEEP	05/17/89	09:40	19.72	1597.403	27.038	0.729	549.32	Sample saved for SNL/NM brine study.
GSEEP	06/06/89	09:40	14.52	1617.403	20.000	0.726	563.84	Sample saved for chemistry. Extra saved for SNL/NM brine study.
GSEEP	06/29/89	10:01	15.95	1640.417	23.014	0.693	579.79	Sample saved for SNL/NM brine study.
GSEEP	07/06/89	09:00	4.67	1647.375	6.958	0.671	584.46	Sample saved for SNL/NM brine study.
GSEEP	07/25/89	09:30	12.60	1666.396	19.021	0.662	597.06	Sample saved for SNL/NM brine study.
GSEEP	08/16/89	09:15	14.73	1688.385	21.989	0.670	611.79	Sample saved for SNL/NM brine study.
GSEEP	09/12/89	08:30	18.68	1715.354	26.969	0.693	630.47	Sample saved for chemistry.
GSEEP	10/11/89	09:47	17.70	1744.408	29.054	0.609	648.17	Sample saved for SNL/NM brine study.
GSEEP	11/15/89	09:30	21.44	1779.396	34.988	0.613	669.61	Sample saved for SNL/NM brine study.
GSEEP	12/13/89	09:13	16.30	1807.384	27.988	0.582	685.91	Sample saved for SNL/NM brine study, sample #896.
GSEEP	01/10/90	09:21	16.40	1835.390	28.006	0.586	702.31	
GSEEP	01/24/90	09:19	9.0	1849.388	13.998	0.643	711.31	
GSEEP	02/07/90	10:07	9.0	1863.422	14.034	0.641	720.31	
GSEEP	02/21/90	09:40	8.32	1877.403	13.981	0.595	728.63	
GSEEP	03/21/90	09:49	16.55	1905.409	28.006	0.591	745.18	
GSEEP	04/24/90	11:16	20.33	1939.469	34.060	0.597	765.51	
GSEEP	05/23/90	11:51	16.66	1968.494	29.025	0.574	782.17	
GSEEP	06/06/90	12:30	10.50	1982.521	0.000	0.000	792.67	
GSEEP	06/20/90	08:56	15.72	1996.372	27.878	0.941	808.39	
GSEEP	07/25/90	08:50	15.0	2031.368	34.996	0.429	823.39	
GSEEP	12/11/90	10:30	2.0	2170.438	0.000	0.000	825.39	Partial removal. First time sampled since 07/25/90.
GSEEP	12/13/90	08:56	49.89	2172.372	141.004	0.368	875.28	Combined with 2.0 liters from 12/11/90. Used 51.89 liters for calculation.
GSEEP	12/20/90	08:23	0.0	2179.349	0.000	0.000	875.28	Could not sample.
GSEEP	01/23/91	09:30	26.14	2213.396	41.024	0.637	901.42	Combined with 2.0 liters from 12/11/90 and 49.89 liters from 12/13/90.
GSEEP	02/27/91	09:52	17.6	2248.411	35.015	0.503	919.02	
GSEEP	03/11/91	08:20	6.9	2260.347	11.936	0.578	925.92	Removed out of cycle for SNL/NM biology study.
GSEEP	03/20/91	10:10	2.02	2269.424	0.000	0.000	927.94	Partial evacuation. First evacuation with bailer, second with pump.
GSEEP	03/21/91	08:45	3.17	2270.365	10.018	0.518	931.11	Combined with 2.02 liters from 03/20/91.
GSEEP	04/24/91	09:02	15.85	2304.376	34.011	0.466	946.96	
GSEEP	05/29/91	09:06	15.72	2339.379	35.003	0.449	962.68	
GSEEP	06/26/91	08:50	12.0	2367.368	27.989	0.429	974.68	
GSEEP	07/11/91	10:20	2.25	2382.431	0.000	0.000	976.93	Partial evacuation.
GSEEP	07/31/91	09:30	11.72	2402.396	35.028	0.399	988.65	Combined with 2.25 liters from 07/11/91.
GSEEP	08/28/91	09:15	11.40	2430.385	27.989	0.407	1000.05	
GSEEP	09/25/91	11:20	2.0	2458.472	0.000	0.000	1002.05	Some brine may have been left in hole.
GSEEP	10/23/91	09:55	15.0	2486.413	56.028	0.303	1017.05	Combined with 2 liters from 10/23/91.

TABLE A-2 (Continued)
BRINE ACCUMULATION DATA TABLE
 Data through December 31, 1993

LOCATION	DATE	TIME	LITERS REMOVED	DAYS	DAYS	LITERS PER DAY	CUMULATIVE	REMARKS
				SINCE 1/1/85	USED FOR CALCULATION		LITERS COLLECTED	
GSEEP	11/27/91	09:40	10.0	2521.403	34.990	0.286	1027.05	
GSEEP	12/10/91	10:30	1.7	2534.438	0.000	0.000	1028.75	Partial removal for SNL/NM.
GSEEP	01/29/92	09:42	13.10	2584.404	63.001	0.235	1041.85	SNL/NM sampling.
GSEEP	02/26/92	09:30	7.23	2612.396	27.992	0.258	1049.08	Saved for SNL/NM.
GSEEP	04/16/92	10:30	3.00	2662.438	50.042	0.060	1052.08	Saved for BSEP.
GSEEP	05/27/92	09:01	13.23	2703.376	40.938	0.323	1065.31	Saved for SNL/NM Chemistry.
GSEEP	07/29/92	09:35	11.75	2766.399	63.023	0.186	1077.06	Saved for SNL/NM.
GSEEP	08/20/92	08:58	1.00	2788.374	0.000	0.000	1078.06	Partial evacuation for BSEP analytical program.
GSEEP	02/26/93	08:45	7.40	2978.365	211.966	0.040	1085.46	
GSEEP	05/19/93	10:15	6.0	3060.427	82.062	0.073	1091.46	Saved for SNL/NM Brine Study. Cleaned hole of accumulated salt buildup: removed all loose material. Pumped hole dry.
GSEEP	06/16/93	10:48	2.75	3088.450	28.023	0.098	1094.21	Saved for SNL/NM Chemistry.
GSEEP	08/19/93	13:44	4.10	3152.572	64.122	0.064	1098.31	
GSEEP	11/12/93	09:44	2.46	3237.406	84.834	0.029	1100.77	
OH20	09/03/85	14:00	NA	245.583	0.000	0.000	0.00	Approximated date this part of drift excavated.
OH20	03/29/89	14:00	NA	1548.583	0.000	0.000	0.00	Horizontal hole drilled 3/28/89 to 3/29/89. Hole drilled with brine. Fluorescien added to drilling fluid.
OH20	03/30/89	11:00	NA	1549.458	0.000	0.000	0.00	New hole. Installed collection device. Hole dry.
OH20	04/18/89	09:45	0	1568.406	1322.830	0.000	0.00	Device left with 50 centibars suction.
OH20	04/26/89	09:50	0	1576.410	8.004	0.000	0.00	Device left with 50 centibars suction.
OH20	06/05/89	09:00	0.31	1616.375	39.965	0.008	0.31	First time sample recovered from this hole. Sample colored with Fluorescien dye. Replaced collection device. Sample saved for chemistry.
OH20	06/20/89	08:30	0.03	1631.354	14.979	0.002	0.34	
OH20	07/06/89	11:00	0.02	1647.458	16.104	0.001	0.36	Collection device retained vacuum. Sample collected for chemistry.
OH20	08/09/89	10:00	0.29	1681.417	33.959	0.009	0.65	Sample collected for chemistry. Pumped collection device, repaired hose end.
OH20	08/23/89	11:22	0.16	1695.474	14.057	0.011	0.81	Sample collected for chemistry. Still yellowish green in color.
OH20	09/14/89	11:05	0.21	1717.462	21.988	0.010	1.02	Sample saved for chemistry.
OH20	10/02/89	11:20	0.27	1735.472	18.010	0.015	1.29	Sample saved for chemistry.
OH20	10/20/89	11:25	0.26	1753.476	18.004	0.014	1.55	Sample saved for chemistry, sample #855.
OH20	11/10/89	10:18	0.29	1774.429	20.953	0.014	1.84	Sample saved for chemistry, sample #868.
OH20	11/29/89	13:00	0.37	1793.542	19.113	0.019	2.21	Sample saved for chemistry, sample #876.
OH20	12/12/89	10:06	0.20	1806.421	12.879	0.016	2.41	Sample saved for chemistry, sample #888.
OH20	01/04/90	11:52	0.27	1829.494	23.073	0.012	2.68	
OH20	01/17/90	09:59	0.21	1842.416	12.922	0.016	2.89	
OH20	01/31/90	10:38	0.21	1856.443	14.027	0.015	3.10	

TABLE A-2 (Continued)
BRINE ACCUMULATION DATA TABLE
 Data through December 31, 1993

LOCATION	DATE	TIME	LITERS REMOVED	DAYS	DAYS	LITERS PER DAY	CUMULATIVE	REMARKS
				SINCE 1/1/85	USED FOR CALCULATION		LITERS COLLECTED	
OH20	02/13/90	10:40	0.18	1869.444	13.001	0.014	3.28	
OH20	02/27/90	12:28	0.24	1883.519	14.075	0.017	3.52	
OH20	03/05/90	11:12	0.20	1889.467	5.948	0.034	3.72	
OH20	03/21/90	09:30	0.08	1905.396	15.929	0.005	3.80	
OH20	04/04/90	12:04	0.18	1919.503	14.107	0.013	3.98	
OH20	04/10/90	10:06	0.11	1925.421	5.918	0.019	4.09	
OH20	05/02/90	10:03	0.10	1947.419	21.998	0.005	4.19	
OH20	05/09/90	09:24	0.09	1954.392	6.973	0.013	4.28	
OH20	05/16/90	11:55	0.07	1961.497	7.105	0.010	4.35	
OH20	05/23/90	13:09	0.18	1968.548	7.051	0.026	4.53	
OH20	05/31/90	09:43	0.09	1976.405	7.857	0.011	4.62	
OH20	06/06/90	11:45	0.08	1982.490	6.085	0.013	4.70	
OH20	06/14/90	10:27	0.09	1990.435	7.945	0.011	4.79	
OH20	06/28/90	10:42	0.18	2004.446	14.011	0.013	4.97	
OH20	07/17/90	09:14	0.24	2023.385	0.000	0.000	5.21	
OH20	07/18/90	11:10	0.01	2024.465	20.019	0.012	5.22	Combined with 0.24 liters from 07/17/90. Used 0.25 liters for calculation.
OH20	07/25/90	10:20	0.09	2031.431	6.966	0.013	5.31	
OH20	08/01/90	11:20	0.09	2038.472	7.041	0.013	5.40	
OH20	08/07/90	10:13	0.08	2044.426	5.954	0.013	5.48	
OH20	08/16/90	10:13	0.11	2053.426	9.000	0.012	5.59	
OH20	08/22/90	10:56	0.08	2059.456	6.030	0.013	5.67	
OH20	08/29/90	10:33	0.09	2066.440	6.984	0.013	5.76	
OH20	09/05/90	10:44	0.09	2073.447	7.007	0.013	5.85	
OH20	09/12/90	09:10	0.08	2080.382	6.935	0.012	5.93	
OH20	09/25/90	11:52	0.14	2093.494	0.000	0.000	6.07	Partial evacuation.
OH20	09/26/90	10:10	0.09	2094.424	14.042	0.016	6.16	Combined with 0.14 liters from 09/25/90. Used 0.23 liters for calculation.
OH20	10/03/90	09:10	0.06	2101.382	6.958	0.009	6.22	
OH20	10/10/90	10:31	0.08	2108.438	7.056	0.011	6.30	
OH20	10/18/90	09:37	0.09	2116.401	7.963	0.011	6.39	
OH20	10/24/90	11:45	0.07	2122.490	6.089	0.011	6.46	
OH20	10/31/90	11:00	0.09	2129.458	6.968	0.013	6.55	
OH20	11/07/90	11:37	0.08	2136.484	7.026	0.011	6.63	
OH20	11/14/90	10:50	0.09	2143.451	6.967	0.013	6.72	
OH20	11/28/90	11:37	0.16	2157.484	14.033	0.011	6.88	
OH20	12/05/90	09:40	0.09	2164.403	6.919	0.013	6.97	
OH20	12/13/90	10:00	0.10	2172.417	8.014	0.012	7.07	
OH20	12/20/90	10:47	0.09	2179.449	7.032	0.013	7.16	
OH20	01/09/91	10:40	0.20	2199.444	19.995	0.010	7.36	
OH20	01/16/91	13:04	0.10	2206.544	7.100	0.014	7.46	
OH20	01/23/91	10:44	0.08	2213.447	6.903	0.012	7.54	
OH20	01/30/91	09:20	0.10	2220.389	6.942	0.014	7.64	
OH20	02/13/91	12:05	0.15	2234.503	14.114	0.011	7.79	
OH20	02/20/91	11:00	0.08	2241.458	6.955	0.012	7.87	
OH20	02/27/91	11:10	0.09	2248.465	7.007	0.013	7.96	
OH20	03/07/91	10:45	0.08	2256.448	7.983	0.010	8.04	

TABLE A-2 (Continued)
BRINE ACCUMULATION DATA TABLE
 Data through December 31, 1993

LOCATION	DATE	TIME	LITERS REMOVED	DAYS	DAYS	LITERS PER DAY	CUMULATIVE	REMARKS
				SINCE 1/1/85	USED FOR CALCULATION		LITERS COLLECTED	
OH20	03/20/91	12:51	0.15	2269.535	13.087	0.011	8.19	
OH20	03/28/91	12:34	0.10	2277.524	7.989	0.013	8.29	
OH20	04/10/91	09:44	0.14	2290.406	12.882	0.011	8.43	
OH20	04/17/91	11:10	0.09	2297.465	7.059	0.013	8.52	
OH20	04/24/91	10:05	0.09	2304.420	6.955	0.013	8.61	
OH20	05/01/91	10:10	0.09	2311.424	7.004	0.013	8.70	
OH20	05/08/91	09:10	0.09	2318.382	6.958	0.013	8.79	
OH20	05/15/91	10:45	0.08	2325.448	7.066	0.011	8.87	
OH20	05/29/91	10:33	0.15	2339.440	13.992	0.011	9.02	
OH20	06/05/91	13:13	0.09	2346.551	7.111	0.013	9.11	
OH20	06/12/91	09:15	0.08	2353.385	6.834	0.012	9.19	
OH20	06/19/91	15:45	0.09	2360.656	7.271	0.012	9.28	
OH20	06/26/91	08:20	0.08	2367.347	6.691	0.012	9.36	
OH20	07/11/91	11:54	0.16	2382.496	15.149	0.011	9.52	
OH20	07/17/91	10:36	0.06	2388.442	5.946	0.010	9.58	
OH20	07/30/91	10:50	0.14	2401.451	13.009	0.011	9.72	
OH20	08/08/91	09:45	0.10	2410.406	8.955	0.011	9.82	
OH20	08/14/91	11:00	0.07	2416.458	6.052	0.012	9.89	
OH20	08/21/91	11:25	0.15	2423.476	7.018	0.021	10.04	
OH20	08/28/91	10:55	0.07	2430.455	6.979	0.010	10.11	
OH20	09/04/91	11:30	0.08	2437.479	7.024	0.011	10.19	
OH20	09/11/91	12:15	0.09	2444.510	7.031	0.013	10.28	
OH20	09/18/91	09:35	0.08	2451.399	6.889	0.012	10.36	
OH20	09/25/91	10:37	0.02	2458.442	7.043	0.003	10.38	
OH20	10/02/91	11:48	0.10	2465.492	7.050	0.014	10.48	
OH20	10/16/91	10:50	0.11	2479.451	13.959	0.008	10.59	
OH20	10/23/91	12:41	0.09	2486.528	7.077	0.013	10.68	
OH20	10/31/91	11:55	0.08	2494.497	7.969	0.010	10.76	
OH20	11/06/91	11:50	0.11	2500.493	5.996	0.018	10.87	
OH20	11/13/91	11:14	0.14	2507.468	6.975	0.020	11.01	
OH20	11/20/91	11:55	0.15	2514.497	7.029	0.021	11.16	
OH20	11/27/91	10:15	0.04	2521.427	6.930	0.006	11.20	
OH20	12/04/91	12:05	0.09	2528.503	7.076	0.013	11.29	
OH20	12/11/91	11:15	0.10	2535.469	6.966	0.014	11.39	
OH20	12/18/91	10:20	0.04	2542.431	6.962	0.006	11.43	
OH20	01/08/92	11:07	0.16	2563.463	21.032	0.008	11.59	
OH20	01/15/92	10:15	0.08	2570.427	6.964	0.011	11.67	
OH20	01/22/92	09:55	0.14	2577.413	6.986	0.020	11.81	
OH20	01/29/92		0.11	2584.000	6.587	0.017	11.92	
OH20	02/12/92	10:00	0.15	2598.417	14.417	0.010	12.07	
OH20	02/19/92	10:25	0.14	2605.434	7.017	0.020	12.21	
OH20	02/26/92	10:06	0.06	2612.421	6.987	0.009	12.27	
OH20	03/11/92	10:15	0.08	2626.427	14.006	0.006	12.35	
OH20	03/18/92	10:15	0.15	2633.427	7.000	0.021	12.50	
OH20	03/25/92	12:30	0.08	2640.521	7.094	0.011	12.58	
OH20	04/01/92	10:10	0.18	2647.424	6.903	0.026	12.76	
OH20	04/07/92	10:25	0.16	2653.434	6.010	0.027	12.92	

TABLE A-2 (Continued)
BRINE ACCUMULATION DATA TABLE
 Data through December 31, 1993

LOCATION	DATE	TIME	LITERS REMOVED	DAYS	DAYS	LITERS PER DAY	CUMULATIVE	REMARKS
				SINCE 1/1/85	USED FOR CALCULATION		LITERS COLLECTED	
OH20	04/15/92	09:45	0.09	2661.406	7.972	0.011	13.01	
OH20	04/22/92	11:03	0.07	2668.460	7.054	0.010	13.08	
OH20	05/06/92	11:40	0.17	2682.486	14.026	0.012	13.25	
OH20	05/13/92	14:10	0.15	2689.590	7.104	0.021	13.40	
OH20	05/21/92	11:30	0.06	2697.479	7.889	0.008	13.46	
OH20	05/27/92	10:08	0.03	2703.422	5.943	0.005	13.49	
OH20	06/09/92	10:00	0.14	2716.417	12.995	0.011	13.63	
OH20	06/18/92	10:20	0.10	2725.431	9.014	0.011	13.73	
OH20	06/25/92	10:55	0.05	2732.455	7.024	0.007	13.78	
OH20	07/01/92	10:10	0.03	2738.424	5.969	0.005	13.81	
OH20	07/08/92		0.06	2745.000	6.576	0.009	13.87	
OH20	07/15/92	10:00	0.05	2752.417	7.417	0.007	13.92	
OH20	07/22/92	11:30	0.06	2759.479	7.062	0.008	13.98	
OH20	07/29/92	10:45	0.05	2766.448	6.969	0.007	14.03	
OH20	08/04/92	10:20	0.07	2772.431	5.983	0.012	14.10	
OH20	08/18/92	10:35	0.13	2786.441	14.010	0.009	14.23	
OH20	09/02/92	10:37	0.15	2801.442	15.001	0.010	14.38	
OH20	09/09/92	10:30	0.08	2808.438	6.996	0.011	14.46	
OH20	09/17/92	10:25	0.05	2816.434	7.996	0.006	14.51	
OH20	09/23/92	10:20	0.04	2822.431	5.997	0.007	14.55	
OH20	09/30/92	11:40	0.04	2829.486	7.055	0.006	14.59	
OH20	10/12/92	13:20	0.10	2841.556	12.070	0.008	14.69	
OH20	10/21/92	13:25	0.04	2850.559	9.003	0.004	14.73	
OH20	10/28/92	09:45	0.04	2857.406	6.847	0.006	14.77	
OH20	11/11/92	13:15	0.03	2871.552	14.146	0.002	14.80	
OH20	11/18/92	13:30	0.03	2878.563	7.011	0.004	14.83	
OH20	11/25/92	10:20	0.00	2885.431	0.000	0.000	14.83	Lost vacuum.
OH20	12/09/92	13:40	0.04	2899.569	21.006	0.002	14.87	
OH20	01/07/93	09:45	0.03	2928.406	28.837	0.001	14.90	
OH20	01/13/93	10:16	0.02	2934.428	6.022	0.003	14.92	
OH20	01/28/93	10:45	0.03	2949.448	15.020	0.002	14.95	
OH20	02/11/93	10:20	0.02	2963.431	13.983	0.001	14.97	
OH20	02/26/93	11:45	0.01	2978.490	15.059	0.001	14.98	
OH20	03/10/93	10:58	0.00	2990.457	11.967	0.000	14.98	
OH20	03/25/93	10:55	0.01	3005.455	14.998	0.001	14.99	
OH20	04/28/93	10:50	0.00	3039.451	33.996	0.000	14.99	
OH20	06/16/93	09:15	0.20	3088.385	48.934	0.004	15.19	
OH20	08/19/93	10:03	0.19	3152.419	0.000	0.000	15.38	Partial evacuation.
OH20	08/20/93	09:16	0.04	3153.386	65.001	0.004	15.42	Combine with 0.19 liter from 08-19-93.
OH20	11/09/93	09:54	0.35	3234.413	0.000	0.000	15.77	Partial evacuation.
OH20	11/12/93	11:15	0.03	3237.469	84.083	0.005	15.80	Combine with 0.35 liter from 11-09-93.
OH21	09/03/85	14:00	NA	245.583	0.000	0.000	0.00	Approximate date this part of drift excavated.
OH21	12/12/88	14:00	NA	1441.583	0.000	0.000	0.00	Horizontal hole drilled 12/12/88 to 12/19/88. Hole drilled with brine.

TABLE A-2 (Continued)
BRINE ACCUMULATION DATA TABLE
 Data through December 31, 1993

LOCATION	DATE	TIME	LITERS REMOVED	DAYS	DAYS	LITERS PER DAY	CUMULATIVE	REMARKS
				SINCE 1/1/85	USED FOR CALCULATION		LITERS COLLECTED	
OH21	02/06/89	10:00	NA	1497.417	0.000	0.000	0.00	Fluorescien added to drilling fluid. New hole. Installed collection device @ 53' in hole. Hole dry.
OH21	02/14/89	09:25	0	1505.392	1259.810	0.000	0.00	Hole plugged with foam. Hole holding vacuum at approx. 50 centibars.
OH21	02/21/89	10:30	0	1512.438	7.046	0.000	0.00	Holding vacuum.
OH21	02/28/89	10:50	0	1519.451	7.013	0.000	0.00	Holding vacuum.
OH21	03/01/89	11:45	NA	1520.490	0.000	0.000	0.00	Device left with approximately 70 centibars suction.
OH21	03/08/89	09:45	0	1527.406	7.955	0.000	0.00	Device left with approximately 50 centibars suction.
OH21	03/15/89	11:35	0	1534.483	7.077	0.000	0.00	Hole dry.
OH21	03/30/89	10:20	0	1549.431	14.948	0.000	0.00	Hole dry.
OH21	04/18/89	09:50	0	1568.410	18.979	0.000	0.00	Device left with approximately 50 centibars suction.
OH21	04/26/89	09:55	0	1576.413	8.003	0.000	0.00	Device left with approximately 50 centibars suction.
OH21	06/05/89	09:10	0	1616.382	39.969	0.000	0.00	Hole dry, no vacuum in collection device. Removed and replaced collection device.
OH21	06/20/89	08:40	0	1631.361	14.979	0.000	0.00	Hole dry.
OH21	07/06/89	11:10	0	1647.465	16.104	0.000	0.00	Hole dry. Collection device retained vacuum.
OH21	08/09/89	10:05	0	1681.420	33.955	0.000	0.00	Hole dry. Pumped collection device, repaired hose ends.
OH21	08/23/89	11:20	0	1695.472	14.052	0.000	0.00	Hole dry.
OH21	10/02/89	11:25	0	1735.476	40.004	0.000	0.00	Hole dry.
OH21	10/20/89	11:25	0	1753.476	18.000	0.000	0.00	Hole dry.
OH21	11/10/89	10:20	0	1774.431	20.955	0.000	0.00	Hole dry.
OH21	11/29/89	12:52	0	1793.536	19.105	0.000	0.00	Hole dry.
OH21	12/12/89	10:10	0	1806.424	12.888	0.000	0.00	Hole dry. Reseat collection device (leaking).
OH21	03/28/91	12:45	0.00	2277.531	471.107	0.000	0.00	Air blowing through tube.
OH21	04/24/91	10:07	0.00	2304.422	26.891	0.000	0.00	Air blowing through tube.
OH21	07/17/91	10:36	0.00	2388.442	84.020	0.000	0.00	Air blowing through tube.
OH21	09/25/91	10:35	0.00	2458.441	69.999	0.000	0.00	Dry. Air blowing through tube. Sampler under vacuum.
OH21	10/31/91	11:48	0.00	2494.492	36.051	0.000	0.00	Dry.
OH21	03/25/93	11:15	0.08	3005.469	510.977	****.***	0.08	Liters/day value > 0.000 and < 0.001.
OH22	09/03/85	14:00	NA	245.583	0.000	0.000	0.00	Approximate date this part of drift excavated.
OH22	12/19/88	14:00	NA	1448.583	1203.000	0.000	0.00	Horizontal hole drilled 12/12/88 to 12/19/88. Hole drilled with brine. Fluorescien added to drilling fluid.
OH22	02/06/89	11:00	NA	1497.458	0.000	0.000	0.00	New hole. Installed collection device @ 52.4' in hole. Hole dry.

TABLE A-2 (Continued)
BRINE ACCUMULATION DATA TABLE
 Data through December 31, 1993

LOCATION	DATE	TIME	LITERS REMOVED	DAYS SINCE 1/1/85	DAYS USED FOR CALCULATION	LITERS PER DAY	CUMULATIVE LITERS COLLECTED	REMARKS
OH22	02/14/89	09:20	0	1505.389	56.806	0.000	0.00	Hole plugged with foam. Hole holding vacuum at approx. 50 centibars.
OH22	02/21/89	10:40	0	1512.444	7.055	0.000	0.00	Holding vacuum.
OH22	02/28/89	10:50	0	1519.451	7.007	0.000	0.00	Not holding vacuum.
OH22	03/01/89	11:00	NA	1520.458	0.000	0.000	0.00	Device left with approximately 70 centibars suction.
OH22	03/08/89	09:45	0	1527.406	7.955	0.000	0.00	Device left with approximately 50 centibars suction.
OH22	03/15/89	11:35	0	1534.483	7.077	0.000	0.00	Hole dry.
OH22	03/30/89	10:22	0	1549.432	14.949	0.000	0.00	Hole dry.
OH22	04/18/89	09:55	0	1568.413	18.981	0.000	0.00	Device left with approximately 50 centibars suction.
OH22	04/26/89	10:00	0	1576.417	8.004	0.000	0.00	Device left with approximately 50 centibars suction.
OH22	06/05/89	09:20	0	1616.389	39.972	0.000	0.00	Hole dry. No vacuum on collection device. Removed and replaced collection device.
OH22	06/20/89	08:45	Trace	1631.365	0.000	0.000	0.00	Trace of brine found in hole.
OH22	07/06/89	11:20	0	1647.472	31.083	0.000	0.00	Hole dry. Collection device retained vacuum.
OH22	08/09/89	10:10	0	1681.424	33.952	0.000	0.00	Hole dry. Pumped collection device, repaired hose ends.
OH22	08/23/89	11:20	0	1695.472	14.048	0.000	0.00	Hole dry.
OH22	10/02/89	11:23	0	1735.474	40.002	0.000	0.00	Hole dry.
OH22	10/20/89	11:25	0	1753.476	18.002	0.000	0.00	Hole dry.
OH22	11/10/89	10:22	0	1774.432	20.956	0.000	0.00	Hole dry.
OH22	11/29/89	12:55	0	1793.538	19.106	0.000	0.00	Hole dry.
OH22	12/12/89	10:12	0	1806.425	12.887	0.000	0.00	Dry. Reseat collection device (leaking).
OH22	03/28/91	12:45	0.00	2277.531	471.106	0.000	0.00	Air blowing through tube.
OH22	04/24/91	10:09	0.00	2304.423	26.892	0.000	0.00	Air blowing through tube.
OH22	07/17/91	10:38	0.00	2388.443	84.020	0.000	0.00	Air blowing through tube.
OH22	09/25/91	10:34	0.02	2458.440	0.000	0.000	0.02	Some brine may have been left in hole.
OH22	10/23/91	12:40	0.57	2486.528	98.085	0.006	0.59	Removed and replaced collection device. Combined with 0.02 liters from 09/25/91.
OH22	10/31/91	11:48	Trace	2494.492	7.964	0.000	0.59	
OH22	11/13/91	11:10	0.00	2507.465	12.973	0.000	0.59	Dry. Air only.
OH22	12/04/91	11:55	Trace	2528.497	21.032	0.000	0.59	
OH22	01/08/92	11:07	0.00	2563.463	34.966	0.000	0.59	Pumped dry.
OH22	01/30/92	10:10	0.18	2585.424	21.961	0.008	0.77	Brine in hole at 19-20 ft. Brine in sampler - sampler checked, found not pressurizing. Fixed stopper, revacuumed, reinstalled @ 11:43.
OH22	03/11/92	10:20	0	2626.431	41.007	0.000	0.77	Dry.
OH22	04/22/92	11:05	0.01	2668.462	42.031	****.***	0.78	Liters/day value > 0.000 and < 0.001.
OH22	06/18/92	10:25	0.00	2725.434	56.972	0.000	0.78	Dry.
OH22	09/03/92	10:00	0.21	2802.417	76.983	0.003	0.99	Removed collector, repositioned.
OH22	03/25/93	11:00	0.00	3005.458	203.041	0.000	0.99	
OH22	11/09/93		Trace	3234.000	0.000	0.000	0.99	Partial evacuation.

TABLE A-2 (Continued)
BRINE ACCUMULATION DATA TABLE
 Data through December 31, 1993

LOCATION	DATE	TIME	LITERS REMOVED	DAYS SINCE 1/1/85	DAYS USED FOR CALCULATION	LITERS PER DAY	CUMULATIVE LITERS COLLECTED	REMARKS
OH23	12/08/85	14:00	NA	341.583	0.000	0.000	0.00	Approximate date this part of drift excavated.
OH23	02/06/89	14:00	NA	1497.583	1384.540	0.000	0.00	Horizontal hole drilled 2/6/89. Hole drilled with brine. Fluorescien added to drilling fluid.
OH23	02/07/89	14:00	NA	1498.583	1.000	0.000	0.00	New hole. Installed collection device @ 153' in hole. Hole dry.
OH23	02/14/89	09:08	0	1505.381	6.798	0.000	0.00	Hole plugged with foam. Hole holding vacuum at approx. 50 centibars.
OH23	02/21/89	10:00	0.00	1512.417	7.036	0.000	0.00	Holding vacuum.
OH23	02/28/89	10:00	0.43	1519.417	7.000	0.061	0.43	Sample clear, warm and effervescent.
OH23	03/08/89	09:30	0.30	1527.396	7.979	0.038	0.73	Device left with approximately 50 centibars suction.
OH23	03/15/89	11:45	0.21	1534.490	7.094	0.030	0.94	Sample saved for chemistry, sample #671.
OH23	03/30/89	10:15	0.52	1549.427	14.937	0.035	1.46	Sample saved for chemistry.
OH23	04/04/89	09:30	0.10	1554.396	4.969	0.020	1.56	Sample saved for chemistry. Device left with approximately 50 centibars suction. Outer 75 feet (approx.) of hole dry.
OH23	04/18/89	09:55	0.10	1568.413	14.017	0.007	1.66	No sample. Device left with approximately 50 centibars suction.
OH23	04/26/89	09:35	0.15	1576.399	7.986	0.019	1.81	Device left with approximately 50 centibars suction. Combined sample saved for chemistry.
OH23	06/05/89	09:30	0.35	1616.396	39.997	0.009	2.16	Sample saved for chemistry.
OH23	06/20/89	08:50	0.62	1631.368	14.972	0.041	2.78	
OH23	07/06/89	11:30	0.37	1647.479	16.111	0.023	3.15	Collection device retained vacuum. Sample saved for chemistry.
OH23	08/09/89	10:15	0.76	1681.427	33.948	0.022	3.91	Sample saved for chemistry. Pumped collection device.
OH23	08/23/89	11:13	0.35	1695.467	14.040	0.025	4.26	Sample saved for chemistry.
OH23	09/14/89	11:14	0.51	1717.468	22.001	0.023	4.77	Sample saved for chemistry.
OH23	10/02/89	11:30	0.36	1735.479	18.011	0.020	5.13	Sample saved for chemistry.
OH23	10/20/89	11:35	0.46	1753.483	18.004	0.026	5.59	Sample saved for chemistry, sample #856.
OH23	11/10/89	10:24	NA	1774.433	0.000	0.000	5.59	Collection device exploded in-hole due to overpressuring during sampling.
OH23	11/15/89	09:00	NA	1779.375	0.000	0.000	5.59	Reinstalled collection device.
OH23	11/29/89	12:51	0.26	1793.535	40.052	0.006	5.85	Sample saved for chemistry, sample #875.
OH23	12/12/89	09:52	0.13	1806.411	12.876	0.010	5.98	Sample saved for chemistry, sample #887. Reseat collection device (leaking).
OH23	01/04/90	11:57	0.11	1829.498	23.087	0.005	6.09	
OH23	01/17/90	09:20	0.23	1842.389	12.891	0.018	6.32	
OH23	03/26/90	09:15	0.60	1910.385	0.000	0.000	6.92	Brine probably left in hole.
OH23	04/04/90	11:53	0.58	1919.495	0.000	0.000	7.50	Brine probably left in hole.
OH23	04/10/90	09:39	0.33	1925.402	83.013	0.018	7.83	Combined with 0.60 liters from 03/26/90 and 0.58 liters from 04/04/90. Used 1.51 liters

TABLE A-2 (Continued)
BRINE ACCUMULATION DATA TABLE
 Data through December 31, 1993

LOCATION	DATE	TIME	LITERS REMOVED	DAYS SINCE 1/1/85	DAYS USED FOR CALCULATION	LITERS PER DAY	CUMULATIVE LITERS COLLECTED	REMARKS
								for calculation.
OH23	04/24/90	08:46	0.29	1939.365	13.963	0.021	8.12	
OH23	05/02/90	09:52	0.17	1947.411	8.046	0.021	8.29	
OH23	05/09/90	09:32	0.15	1954.397	6.986	0.021	8.44	
OH23	05/16/90	11:45	0.17	1961.490	7.093	0.024	8.61	
OH23	05/23/90	13:07	0.13	1968.547	7.057	0.018	8.74	
OH23	05/31/90	09:35	0.16	1976.399	7.852	0.020	8.90	
OH23	06/06/90	11:40	0.12	1982.486	6.087	0.020	9.02	
OH23	06/14/90	10:35	0.17	1990.441	7.955	0.021	9.19	
OH23	06/28/90	10:36	0.38	2004.442	14.001	0.027	9.57	
OH23	07/17/90	09:04	0.33	2023.378	0.000	0.000	9.90	
OH23	07/18/90	11:05	0.10	2024.462	20.020	0.021	10.00	Combined with 0.33 liters from 07/17/90. Used 0.43 liters for calculation.
OH23	07/25/90	10:15	0.10	2031.427	6.965	0.014	10.10	
OH23	08/01/90	11:15	0.14	2038.469	7.042	0.020	10.24	
OH23	08/07/90	09:58	0.14	2044.415	5.946	0.024	10.38	
OH23	08/16/90	09:42	0.15	2053.404	8.989	0.017	10.53	
OH23	08/22/90	10:51	0.10	2059.452	6.048	0.017	10.63	
OH23	08/29/90	10:30	0.15	2066.438	6.986	0.021	10.78	
OH23	09/05/90	10:40	0.17	2073.444	7.006	0.024	10.95	
OH23	09/12/90	09:00	0.10	2080.375	6.931	0.014	11.05	
OH23	09/25/90	11:42	0.21	2093.488	0.000	0.000	11.26	
OH23	09/26/90	09:53	0.06	2094.412	14.037	0.019	11.32	Combined with 0.21 liters from 09/25/90. Used 0.27 liters for calculation.
OH23	10/03/90	09:05	0.11	2101.378	6.966	0.016	11.43	
OH23	10/10/90	10:22	0.13	2108.432	7.054	0.018	11.56	
OH23	10/18/90	09:30	0.15	2116.396	7.964	0.019	11.71	
OH23	10/24/90	11:30	0.10	2122.479	6.083	0.016	11.81	
OH23	10/31/90	10:53	0.11	2129.453	6.974	0.016	11.92	
OH23	11/07/90	11:40	0.10	2136.486	7.033	0.014	12.02	
OH23	11/14/90	10:45	0.13	2143.448	6.962	0.019	12.15	
OH23	11/28/90	11:32	0.22	2157.481	14.033	0.016	12.37	
OH23	12/05/90	09:35	0.10	2164.399	6.918	0.014	12.47	
OH23	12/13/90	10:15	0.14	2172.427	8.028	0.017	12.61	
OH23	12/20/90	10:30	0.10	2179.438	7.011	0.014	12.71	
OH23	01/09/91	10:48	0.24	2199.450	0.000	0.000	12.95	Some brine may have been left in hole.
OH23	01/16/91	13:15	0.43	2206.552	27.114	0.025	13.38	Combined with 0.24 liters from 01/09/91. Collection device replaced on 01/10/91.
OH23	01/23/91	10:50	0.08	2213.451	6.899	0.012	13.46	
OH23	01/30/91	09:01	0.12	2220.376	6.925	0.017	13.58	
OH23	02/13/91	12:15	0.20	2234.510	14.134	0.014	13.78	
OH23	02/20/91	11:20	0.12	2241.472	6.962	0.017	13.90	
OH23	02/27/91	11:15	0.11	2248.469	6.997	0.016	14.01	
OH23	03/07/91	10:50	0.11	2256.451	7.982	0.014	14.12	
OH23	03/20/91	12:50	0.21	2269.535	13.084	0.016	14.33	
OH23	03/28/91	12:15	0.12	2277.510	7.975	0.015	14.45	
OH23	04/10/91	09:55	0.20	2290.413	12.903	0.016	14.65	

TABLE A-2 (Continued)
BRINE ACCUMULATION DATA TABLE
 Data through December 31, 1993

LOCATION	DATE	TIME	LITERS REMOVED	DAYS	DAYS	LITERS PER DAY	CUMULATIVE	REMARKS
				SINCE 1/1/85	USED FOR CALCULATION		LITERS COLLECTED	
OH23	04/17/91	10:59	0.11	2297.458	7.045	0.016	14.76	
OH23	04/24/91	10:10	0.07	2304.424	6.966	0.010	14.83	
OH23	05/01/91	10:05	0.12	2311.420	6.996	0.017	14.95	
OH23	05/08/91	09:15	0.06	2318.385	6.965	0.009	15.01	
OH23	05/15/91	11:00	0.13	2325.458	7.073	0.018	15.14	
OH23	05/29/91	10:28	0.04	2339.436	13.978	0.003	15.18	
OH23	06/05/91	13:10	0.04	2346.549	7.113	0.006	15.22	
OH23	06/12/91	09:00	0.02	2353.375	6.826	0.003	15.24	
OH23	06/19/91	15:35	0.43	2360.649	7.274	0.059	15.67	
OH23	06/26/91	08:15	0.10	2367.344	6.695	0.015	15.77	
OH23	07/11/91	12:05	0.23	2382.503	15.159	0.015	16.00	
OH23	07/17/91	10:40	0.09	2388.444	5.941	0.015	16.09	
OH23	07/30/91	10:45	0.18	2401.448	13.004	0.014	16.27	
OH23	08/08/91	09:42	0.14	2410.404	8.956	0.016	16.41	
OH23	08/14/91	11:30	0.13	2416.479	6.075	0.021	16.54	
OH23	08/21/91	11:20	0.12	2423.472	6.993	0.017	16.66	
OH23	08/28/91	10:50	0.07	2430.451	6.979	0.010	16.73	
OH23	09/04/91	11:35	0.14	2437.483	7.032	0.020	16.87	
OH23	09/11/91	12:10	0.04	2444.507	7.024	0.006	16.91	
OH23	09/18/91	09:30	0.16	2451.396	6.889	0.023	17.07	
OH23	09/25/91	10:30	0.09	2458.438	7.042	0.013	17.16	
OH23	10/02/91	11:44	0.10	2465.489	7.051	0.014	17.26	
OH23	10/16/91	10:57	0.16	2479.456	13.967	0.011	17.42	
OH23	10/23/91	12:35	0.11	2486.524	7.068	0.016	17.53	
OH23	10/31/91	11:40	0.08	2494.486	7.962	0.010	17.61	
OH23	11/06/91	12:03	0.09	2500.502	6.016	0.015	17.70	
OH23	11/13/91	11:00	0.05	2507.458	6.956	0.007	17.75	
OH23	11/20/91	11:50	0.16	2514.493	7.035	0.023	17.91	
OH23	11/27/91	10:30	0.10	2521.438	6.945	0.014	18.01	
OH23	12/04/91	11:50	0.10	2528.493	7.055	0.014	18.11	
OH23	12/11/91	11:30	0.09	2535.479	6.986	0.013	18.20	
OH23	12/18/91	11:00	0.07	2542.458	6.979	0.010	18.27	
OH23	01/08/92	11:03	0.26	2563.460	21.002	0.012	18.53	
OH23	01/15/92	10:10	0.08	2570.424	6.964	0.011	18.61	
OH23	01/22/92	09:58	0.11	2577.415	6.991	0.016	18.72	
OH23	01/29/92		0.13	2584.000	-6.585	-0.020	18.85	
OH23	02/12/92	10:15	0.13	2598.427	14.427	0.009	18.98	
OH23	02/19/92	10:28	0.14	2605.436	7.009	0.020	19.12	
OH23	02/26/92	10:12	0.05	2612.425	6.989	0.007	19.17	
OH23	03/11/92	10:25	0.21	2626.434	14.009	0.015	19.38	
OH23	03/18/92	10:25	0.10	2633.434	7.000	0.014	19.48	
OH23	03/25/92	12:35	0.08	2640.524	7.090	0.011	19.56	
OH23	04/01/92	10:20	0.10	2647.431	6.907	0.014	19.66	
OH23	04/07/92	10:35	0.07	2653.441	6.010	0.012	19.73	
OH23	04/15/92	09:55	0.14	2661.413	7.972	0.018	19.87	
OH23	04/22/92		0.10	2668.000	6.587	0.015	19.97	
OH23	05/06/92	11:45	0.20	2682.490	14.490	0.014	20.17	

TABLE A-2 (Continued)
BRINE ACCUMULATION DATA TABLE
 Data through December 31, 1993

LOCATION	DATE	TIME	LITERS REMOVED	DAYS SINCE 1/1/85	DAYS USED FOR CALCULATION	LITERS PER DAY	CUMULATIVE LITERS COLLECTED	REMARKS
OH23	05/13/92	14:25	0.17	2689.601	7.111	0.024	20.34	
OH23	05/21/92	11:23	0.10	2697.474	7.873	0.013	20.44	
OH23	05/27/92	10:02	0.08	2703.418	5.944	0.013	20.52	
OH23	06/09/92	10:10	0.16	2716.424	13.006	0.012	20.68	
OH23	06/18/92	10:30	0.12	2725.438	9.014	0.013	20.80	
OH23	06/25/92	10:50	0.08	2732.451	7.013	0.011	20.88	
OH23	07/01/92	10:15	0.08	2738.427	5.976	0.013	20.96	
OH23	07/08/92		0.09	2745.000	6.573	0.014	21.05	
OH23	07/15/92	10:20	0.09	2752.431	7.431	0.012	21.14	
OH23	07/22/92	11:35	0.09	2759.483	7.052	0.013	21.23	
OH23	07/29/92	10:42	0.085	2766.446	6.963	0.012	21.32	
OH23	08/04/92	10:27	0.09	2772.435	5.989	0.015	21.41	
OH23	08/18/92	10:40	0.17	2786.444	14.009	0.012	21.58	
OH23	09/02/92	10:20	0.16	2801.431	14.987	0.011	21.74	
OH23	09/09/92	10:35	0.11	2808.441	7.010	0.016	21.85	
OH23	09/17/92	10:30	0.09	2816.438	7.997	0.011	21.94	
OH23	09/23/92	10:25	0.08	2822.434	5.996	0.013	22.02	
OH23	09/30/92	11:45	0.10	2829.490	7.056	0.014	22.12	
OH23	10/12/92	13:25	0.14	2841.559	12.069	0.012	22.26	
OH23	10/21/92	13:30	0.10	2850.563	9.004	0.011	22.36	
OH23	10/28/92	09:55	0.08	2857.413	6.850	0.012	22.44	
OH23	11/11/92	13:35	0.15	2871.566	14.153	0.011	22.59	
OH23	11/18/92	13:35	0.09	2878.566	7.000	0.013	22.68	
OH23	11/25/92	10:25	0.10	2885.434	6.868	0.015	22.78	
OH23	12/09/92	13:50	0.15	2899.576	14.142	0.011	22.93	
OH23	01/07/93	09:55	0.34	2928.413	28.837	0.012	23.27	
OH23	01/13/93	10:20	0.07	2934.431	6.018	0.012	23.34	
OH23	01/28/93	11:00	0.18	2949.458	15.027	0.012	23.52	
OH23	02/11/93	10:40	0.17	2963.444	13.986	0.012	23.69	
OH23	02/26/93	11:55	0.14	2978.497	15.053	0.009	23.83	
OH23	03/10/93	11:05	0.14	2990.462	11.965	0.012	23.97	
OH23	03/25/93	11:20	0.20	3005.472	15.010	0.013	24.17	
OH23	04/28/93	10:55	0.41	3039.455	33.983	0.012	24.58	
OH23	06/16/93	09:10	0.55	3088.382	48.927	0.011	25.13	
OH23	08/19/93	09:38	0.65	3152.401	0.000	0.000	25.78	Partial evacuation.
OH23	08/20/93	09:12	0.08	3153.383	65.001	0.011	25.86	Combine with 0.65 liters from 08-19-93.
OH23	11/09/93	09:51	0.62	3234.410	0.000	0.000	26.48	Partial evacuation.
OH23	11/12/93	11:20	0.27	3237.472	84.089	0.011	26.75	Combine with 0.62 liters from 11-09-93.
OH24	12/08/85	14:00	NA	341.583	0.000	0.000	0.00	Approximate date this part of drift excavated.
OH24	03/06/89	14:00	NA	1525.583	1184.000	0.000	0.00	Horizontal hole drilled 3/2/89 to 3/6/89.
OH24	03/08/89	09:50	NA	1527.410	0.000	0.000	0.00	New hole. Installed collection device. Hole dry.
OH24	03/15/89	11:45	0	1534.490	8.907	0.000	0.00	Hole dry.
OH24	03/30/89	10:25	0	1549.434	14.944	0.000	0.00	Hole dry.

TABLE A-2 (Continued)
BRINE ACCUMULATION DATA TABLE
 Data through December 31, 1993

LOCATION	DATE	TIME	LITERS REMOVED	DAYS SINCE 1/1/85	DAYS USED FOR CALCULATION	LITERS PER DAY	CUMULATIVE LITERS COLLECTED	REMARKS
OH24	04/18/89	10:00	0	1568.417	18.983	0.000	0.00	Device left with approximately 50 centibars suction.
OH24	04/26/89	09:40	0	1576.403	7.986	0.000	0.00	Device left with approximately 50 centibars suction.
OH24	06/05/89	09:40	0.05	1616.403	40.000	0.001	0.05	First time sample recovered. No vacuum in collection device. Collection device removed and replaced.
OH24	06/20/89	09:00	0.03	1631.375	14.972	0.002	0.08	
OH24	07/06/89	11:40	0.01	1647.486	16.111	0.001	0.09	Collection device retained vacuum. Sample saved for chemistry.
OH24	08/09/89	10:20	0	1681.431	33.945	0.000	0.09	Hole dry. Pumped collection device.
OH24	08/23/89	11:18	0	1695.471	14.040	0.000	0.09	Hole dry.
OH24	10/02/89	11:35	0	1735.483	40.012	0.000	0.09	Hole dry.
OH24	10/20/89	11:35	0	1753.483	18.000	0.000	0.09	Hole dry.
OH24	11/10/89	10:26	0	1774.435	20.952	0.000	0.09	Hole dry.
OH24	11/29/89	12:58	0	1793.540	19.105	0.000	0.09	Hole dry.
OH24	12/12/89	09:54	0	1806.413	12.873	0.000	0.09	Hole dry. Reseat collection device (leaking).
OH24	04/10/90	09:46	0.09	1925.407	118.994	0.001	0.18	
OH24	04/24/90	08:46	0.03	1939.365	13.958	0.002	0.21	
OH24	05/02/90	09:55	NA	1947.413	0.000	0.000	0.21	Trace.
OH24	08/10/90	09:40	NA	2047.403	0.000	0.000	0.21	Cleaned, checked, and reinstalled vacuum up to 50 centibars. Checked in one hour. Sampler holding vacuum.
OH24	04/24/91	10:12	0.00	2304.425	0.000	0.000	0.21	Air blowing through tube.
OH24	07/17/91	10:45	0.00	2388.448	0.000	0.000	0.21	Air blowing through tube.
OH24	09/25/91	10:18	0.00	2458.429	0.000	0.000	0.21	Air blowing through tube.
OH24	10/23/91	12:30	0.53	2486.521	547.156	0.001	0.74	Replaced broken collection device. Used 547.156 days.
OH24	10/31/91	11:42	Trace	2494.488	7.967	0.000	0.74	Hole wet at 25 feet.
OH24	11/13/91	11:05	0.02	2507.462	12.974	0.002	0.76	
OH24	12/04/91	11:45	Trace	2528.490	21.028	0.000	0.76	
OH24	01/08/92	11:03	0.00	2563.460	34.970	0.000	0.76	Pumped dry.
OH24	01/30/92	10:30	0.03	2585.438	21.978	0.001	0.79	Hole shows brine on plastic hose @ 19.5 ft. (into hole) Sampler had minimal brine. Revacuumed and reinstalled @ 11:18.
OH24	03/11/92	10:30	0	2626.438	41.000	0.000	0.79	Dry.
OH24	04/22/92		0.00	2668.000	41.562	0.000	0.79	
OH24	06/18/92	10:35	0.0	2725.441	57.441	0.000	0.79	Dry.
OH24	09/03/92	10:30	Trace	2802.438	76.997	0.000	0.79	Removed collector, repositioned.
OH24	03/25/93	11:25	0.26	3005.476	203.038	0.001	1.05	
OH24	11/09/93		Trace	3234.000	0.000	0.000	1.05	Partial evacuation.
OH25	12/08/85	14:00	NA	341.583	228.524	0.000	0.00	Approximate date this part of drift excavated.
OH25	03/27/89	14:00	NA	1546.583	1205.000	0.000	0.00	Horizontal hole drilled on 3/27/89.

TABLE A-2 (Continued)
BRINE ACCUMULATION DATA TABLE
 Data through December 31, 1993

LOCATION	DATE	TIME	LITERS REMOVED	DAYS SINCE 1/1/85	DAYS USED FOR CALCULATION	LITERS PER DAY	CUMULATIVE LITERS COLLECTED	REMARKS
OH25	03/30/89	10:27	0	1549.435	0.000	0.000	0.00	Hole dry.
OH25	04/18/89	10:05	0	1568.420	21.837	0.000	0.00	Device left with approximately 50 centibars suction.
OH25	04/26/89	09:45	0	1576.406	7.986	0.000	0.00	Device left with approximately 50 centibars suction.
OH25	06/05/89	09:50	0	1616.410	40.004	0.000	0.00	Hole dry. No vacuum on collection device. Collection device removed and replaced.
OH25	06/20/89	09:10	0	1631.382	14.972	0.000	0.00	Hole dry.
OH25	07/06/89	11:40	0.01	1647.486	16.104	0.001	0.01	Collection device retained vacuum. Sample saved for chemistry.
OH25	08/09/89	10:25	0	1681.434	33.948	0.000	0.01	Hole dry.
OH25	08/23/89	11:18	0	1695.471	14.037	0.000	0.01	Hole dry.
OH25	10/02/89	11:35	0	1735.483	40.012	0.000	0.01	Hole dry.
OH25	10/20/89	11:35	0	1753.483	18.000	0.000	0.01	Hole dry.
OH25	11/10/89	10:30	0	1774.438	20.955	0.000	0.01	Hole dry.
OH25	11/29/89	13:02	0	1793.543	19.105	0.000	0.01	Hole dry.
OH25	12/12/89	09:58	0	1806.415	12.872	0.000	0.01	Hole dry. Reseat collection device (leaking).
OH25	08/10/90	09:50	NA	2047.410	0.000	0.000	0.01	Cleaned, checked, and reinstalled vacuum up to 50 centibars. Checked in one hour. Sampler holding vacuum.
OH25	04/24/91	10:14	0.00	2304.426	498.011	0.000	0.01	Air blowing through tube.
OH25	07/17/91	10:47	0.00	2388.449	84.023	0.000	0.01	Air blowing through tube.
OH25	09/25/91	10:15	0.06	2458.427	69.978	0.001	0.07	
OH25	10/31/91	11:42	0.00	2494.488	36.061	0.000	0.07	Dry. Hole wet at 30 feet.
OH25	03/25/93	11:27	0.07	3005.477	510.989	****.***	0.14	Liter/day value is > 0.000 and < 0.001.
OH26	08/05/86	14:00	NA	581.583	0.000	0.000	0.00	Approximate date this part of drift excavated.
OH26	03/27/89	14:00	NA	1546.583	965.000	0.000	0.00	Horizontal hole drilled on 3/27/89. Hole drilled with brine. Fluorescien added to drilling fluid.
OH26	03/30/89	10:00	NA	1549.417	0.000	0.000	0.00	New hole. Installed collection device. Hole dry.
OH26	04/18/89	10:10	0	1568.424	21.841	0.000	0.00	Device left with approximately 50 centibars suction.
OH26	04/26/89	09:15	0	1576.385	7.961	0.000	0.00	Device left with approximately 50 centibars suction.
OH26	06/05/89	10:00	0.20	1616.417	40.032	0.005	0.20	First time sample recovered. Collection device removed and replaced. Sample saved for chemistry.
OH26	06/20/89	09:15	0.05	1631.385	14.968	0.003	0.25	
OH26	07/06/89	11:50	0.49	1647.493	16.108	0.030	0.74	Collection device retained vacuum. Sample saved for chemistry.
OH26	08/09/89	10:30	0.67	1681.438	33.945	0.020	1.41	Sample saved for chemistry.
OH26	08/23/89	10:30	0.55	1695.438	14.000	0.039	1.96	Sample saved for chemistry.

TABLE A-2 (Continued)
BRINE ACCUMULATION DATA TABLE
 Data through December 31, 1993

LOCATION	DATE	TIME	LITERS REMOVED	DAYS	DAYS	LITERS PER DAY	CUMULATIVE	REMARKS
				SINCE 1/1/85	USED FOR CALCULATION		LITERS COLLECTED	
OH26	09/14/89	11:21	0.51	1717.473	22.035	0.023	2.47	Sample saved for chemistry.
OH26	10/02/89	11:40	0.56	1735.486	18.013	0.031	3.03	Sample saved for chemistry.
OH26	10/20/89	11:45	0.45	1753.490	18.004	0.025	3.48	Sample saved for chemistry, sample #857.
OH26	11/10/89	11:04	0.48	1774.461	20.971	0.023	3.96	Sample saved for chemistry, sample #866.
OH26	11/29/89	12:40	0.32	1793.528	19.067	0.017	4.28	Sample saved for chemistry, sample #874.
OH26	12/12/89	09:38	0.32	1806.401	12.873	0.025	4.60	Sample saved for chemistry, sample #885.
OH26	01/04/90	12:05	0.23	1829.503	23.102	0.010	4.83	
OH26	01/17/90	08:58	0.36	1842.374	12.871	0.028	5.19	
OH26	01/31/90	10:54	0.26	1856.454	14.080	0.018	5.45	
OH26	02/13/90	11:30	0.26	1869.479	13.025	0.020	5.71	
OH26	02/27/90	12:46	0.21	1883.532	14.053	0.015	5.92	Brine probably left in hole.
OH26	03/05/90	11:27	0.26	1889.477	5.945	0.044	6.18	
OH26	03/21/90	09:26	0.18	1905.393	15.916	0.011	6.36	
OH26	04/04/90	11:49	0.28	1919.492	14.099	0.020	6.64	Brine probably left in hole.
OH26	04/10/90	09:17	0.22	1925.387	5.895	0.037	6.86	
OH26	04/24/90	08:33	0.19	1939.356	13.969	0.014	7.05	
OH26	05/02/90	09:45	0.24	1947.406	8.050	0.030	7.29	
OH26	05/09/90	09:46	0.21	1954.407	7.001	0.030	7.50	
OH26	05/16/90	11:30	0.15	1961.479	7.072	0.021	7.65	
OH26	05/23/90	13:03	0.12	1968.544	7.065	0.017	7.77	
OH26	05/31/90	09:29	0.14	1976.395	7.851	0.018	7.91	
OH26	06/06/90	11:35	0.14	1982.483	6.088	0.023	8.05	
OH26	06/14/90	10:42	0.14	1990.446	7.963	0.018	8.19	
OH26	06/28/90	10:27	0.16	2004.435	13.989	0.011	8.35	
OH26	07/17/90	08:56	0.18	2023.372	0.000	0.000	8.53	
OH26	07/18/90	11:00	0.28	2024.458	20.023	0.023	8.81	Combined with 0.18 liters 07/17/90. Used 0.46 liters for calculation.
OH26	07/25/90	10:07	0.05	2031.422	6.964	0.007	8.86	Brine probably left in hole.
OH26	08/01/90	11:05	0.25	2038.462	7.040	0.036	9.11	
OH26	08/07/90	09:40	0.11	2044.403	5.941	0.019	9.22	
OH26	08/16/90	09:18	0.12	2053.388	8.985	0.013	9.34	
OH26	08/22/90	10:44	0.10	2059.447	6.059	0.017	9.44	
OH26	08/29/90	10:23	0.11	2066.433	6.986	0.016	9.55	
OH26	09/05/90	10:34	0.11	2073.440	7.007	0.016	9.66	
OH26	09/12/90	08:45	0.10	2080.365	6.925	0.014	9.76	
OH26	09/25/90	11:26	0.19	2093.476	0.000	0.000	9.95	
OH26	09/26/90	09:48	0.10	2094.408	14.043	0.021	10.05	Combined with 0.19 liters from 09/25/90. Used 0.29 liters for calculation.
OH26	10/03/90	08:55	0.10	2101.372	6.964	0.014	10.15	
OH26	10/10/90	10:14	0.11	2108.426	7.054	0.016	10.26	
OH26	10/18/90	09:25	0.13	2116.392	7.966	0.016	10.39	
OH26	10/24/90	11:16	0.11	2122.469	6.077	0.018	10.50	
OH26	10/31/90	10:43	0.12	2129.447	6.978	0.017	10.62	
OH26	11/07/90	11:43	0.13	2136.488	7.041	0.018	10.75	
OH26	11/14/90	10:40	0.10	2143.444	6.956	0.014	10.85	
OH26	11/28/90	11:20	0.21	2157.472	14.028	0.015	11.06	
OH26	12/05/90	09:30	0.14	2164.396	6.924	0.020	11.20	

TABLE A-2 (Continued)
BRINE ACCUMULATION DATA TABLE
 Data through December 31, 1993

LOCATION	DATE	TIME	LITERS REMOVED	DAYS	DAYS	LITERS PER DAY	CUMULATIVE	REMARKS
				SINCE 1/1/85	USED FOR CALCULATION		LITERS COLLECTED	
OH26	12/13/90	10:20	0.13	2172.431	8.035	0.016	11.33	
OH26	12/20/90	10:20	0.11	2179.431	7.000	0.016	11.44	
OH26	01/09/91	10:50	0.29	2199.451	20.020	0.014	11.73	
OH26	01/16/91	13:25	0.13	2206.559	7.108	0.018	11.86	
OH26	01/23/91	10:55	0.17	2213.455	6.896	0.025	12.03	
OH26	01/30/91	08:36	0.11	2220.358	6.903	0.016	12.14	
OH26	02/13/91	12:20	0.18	2234.514	14.156	0.013	12.32	
OH26	02/20/91	11:25	0.12	2241.476	6.962	0.017	12.44	
OH26	02/27/91	11:20	0.11	2248.472	6.996	0.016	12.55	
OH26	03/07/91	10:55	0.11	2256.455	7.983	0.014	12.66	
OH26	03/20/91	12:43	0.19	2269.530	13.075	0.015	12.85	
OH26	03/28/91	11:53	0.11	2277.495	7.965	0.014	12.96	
OH26	04/10/91	10:02	0.20	2290.418	12.923	0.015	13.16	
OH26	04/17/91	10:54	0.12	2297.454	7.036	0.017	13.28	
OH26	04/24/91	10:25	0.12	2304.434	6.980	0.017	13.40	
OH26	05/01/91	10:00	0.10	2311.417	6.983	0.014	13.50	
OH26	05/08/91	09:20	0.10	2318.389	6.972	0.014	13.60	
OH26	05/15/91	11:10	0.08	2325.465	7.076	0.011	13.68	
OH26	05/29/91	10:18	0.19	2339.429	13.964	0.014	13.87	
OH26	06/05/91	13:07	0.14	2346.547	7.118	0.020	14.01	
OH26	06/12/91	08:57	0.17	2353.373	6.826	0.025	14.18	
OH26	06/19/91	15:22	0.16	2360.640	7.267	0.022	14.34	
OH26	06/26/91	08:12	0.10	2367.342	6.702	0.015	14.44	
OH26	07/11/91	12:08	0.19	2382.506	15.164	0.013	14.63	
OH26	07/17/91	11:00	0.10	2388.458	5.952	0.017	14.73	
OH26	07/30/91	10:40	0.06	2401.444	0.000	0.000	14.79	Partial evacuation.
OH26	07/31/91	09:45	0.14	2402.406	13.948	0.014	14.93	Combined with 0.06 liters from 07/30/91.
OH26	08/08/91	09:39	0.15	2410.402	7.996	0.019	15.08	
OH26	08/14/91	11:35	0.11	2416.483	6.081	0.018	15.19	
OH26	08/21/91	11:17	0.13	2423.470	6.987	0.019	15.32	
OH26	08/28/91	10:46	0.09	2430.449	6.979	0.013	15.41	
OH26	09/04/91	11:40	0.09	2437.486	7.037	0.013	15.50	
OH26	09/11/91	12:05	0.05	2444.503	7.017	0.007	15.55	
OH26	09/18/91	09:25	0.13	2451.392	6.889	0.019	15.68	
OH26	09/25/91	09:56	0.11	2458.414	7.022	0.016	15.79	
OH26	10/02/91	11:40	0.10	2465.486	7.072	0.014	15.89	
OH26	10/16/91	11:00	0.10	2479.458	13.972	0.007	15.99	
OH26	10/23/91	10:25	0.15	2486.434	6.976	0.022	16.14	
OH26	10/31/91	11:39	0.13	2494.485	8.051	0.016	16.27	
OH26	11/06/91	12:08	0.06	2500.506	6.021	0.010	16.33	
OH26	11/13/91	10:50	0.07	2507.451	6.945	0.010	16.40	
OH26	11/20/91	11:43	0.13	2514.488	7.037	0.018	16.53	
OH26	11/27/91	10:36	0.09	2521.442	6.954	0.013	16.62	
OH26	12/04/91	11:30	0.08	2528.479	7.037	0.011	16.70	
OH26	12/11/91	11:45	0.09	2535.490	7.011	0.013	16.79	
OH26	12/18/91	11:05	0.12	2542.462	6.972	0.017	16.91	
OH26	01/08/92	11:00	0.23	2563.458	20.996	0.011	17.14	

TABLE A-2 (Continued)
BRINE ACCUMULATION DATA TABLE
 Data through December 31, 1993

LOCATION	DATE	TIME	LITERS REMOVED	DAYS	DAYS	LITERS PER DAY	CUMULATIVE	REMARKS
				SINCE 1/1/85	USED FOR CALCULATION		LITERS COLLECTED	
OH26	01/15/92	10:08	0.10	2570.422	6.964	0.014	17.24	
OH26	01/22/92	10:10	0.08	2577.424	7.002	0.011	17.32	
OH26	01/29/92		0.14	2584.000	6.576	0.021	17.46	
OH26	02/12/92	10:20	0.15	2598.431	14.431	0.010	17.61	
OH26	02/19/92	10:32	0.11	2605.439	7.008	0.016	17.72	
OH26	02/26/92	10:15	0.06	2612.427	6.988	0.009	17.78	
OH26	03/11/92	10:35	0.16	2626.441	14.014	0.011	17.94	
OH26	03/18/92	10:35	0.11	2633.441	7.000	0.016	18.05	
OH26	03/25/92	12:40	0.10	2640.528	7.087	0.014	18.15	
OH26	04/01/92	10:35	0.08	2647.441	6.913	0.012	18.23	
OH26	04/07/92	10:45	0.05	2653.448	6.007	0.008	18.28	
OH26	04/15/92	10:05	0.13	2661.420	7.972	0.016	18.41	
OH26	04/22/92		0.09	2668.000	6.580	0.014	18.50	
OH26	05/06/92	11:50	0.18	2682.493	14.493	0.012	18.68	
OH26	05/13/92	14:40	0.16	2689.611	7.118	0.022	18.84	
OH26	05/21/92	11:18	0.08	2697.471	7.860	0.010	18.92	
OH26	05/27/92	10:14	0.06	2703.426	5.955	0.010	18.98	
OH26	06/09/92	10:20	0.15	2716.431	13.005	0.012	19.13	
OH26	06/18/92	10:40	0.15	2725.444	9.013	0.017	19.28	
OH26	06/25/92	10:45	0.07	2732.448	7.004	0.010	19.35	
OH26	07/01/92	10:20	0.08	2738.431	5.983	0.013	19.43	
OH26	07/08/92		0.11	2745.000	6.569	0.017	19.54	
OH26	07/15/92	10:40	0.07	2752.444	7.444	0.009	19.61	
OH26	07/22/92	11:40	0.10	2759.486	7.042	0.014	19.71	
OH26	07/29/92	10:38	0.09	2766.443	6.957	0.013	19.80	
OH26	08/04/92	10:33	0.07	2772.440	5.997	0.012	19.87	
OH26	08/18/92	10:47	0.15	2786.449	14.009	0.011	20.02	
OH26	09/02/92	10:15	0.18	2801.427	14.978	0.012	20.20	
OH26	09/09/92	10:40	0.09	2808.444	7.017	0.013	20.29	
OH26	09/17/92	10:35	0.14	2816.441	7.997	0.018	20.43	
OH26	09/23/92	10:30	0.05	2822.438	5.997	0.008	20.48	
OH26	09/30/92	11:50	0.06	2829.493	7.055	0.009	20.54	
OH26	10/12/92	13:30	0.15	2841.563	12.070	0.012	20.69	
OH26	10/21/92	13:45	0.09	2850.573	9.010	0.010	20.78	
OH26	10/28/92	10:05	0.08	2857.420	6.847	0.012	20.86	
OH26	11/11/92	13:35	0.15	2871.566	14.146	0.011	21.01	
OH26	11/18/92	13:40	0.10	2878.569	7.003	0.014	21.11	
OH26	11/25/92	10:30	0.07	2885.438	6.869	0.010	21.18	
OH26	12/09/92	14:00	0.16	2899.583	14.145	0.011	21.34	
OH26	01/07/93	10:05	0.32	2928.420	28.837	0.011	21.66	
OH26	01/13/93	10:23	0.06	2934.433	6.013	0.010	21.72	
OH26	01/28/93	11:15	0.18	2949.469	15.036	0.012	21.90	
OH26	02/11/93	10:58	0.11	2963.457	13.988	0.008	22.01	
OH26	02/26/93	12:10	0.23	2978.507	15.050	0.015	22.24	
OH26	03/10/93	11:10	0.13	2990.465	11.958	0.011	22.37	
OH26	03/25/93	11:35	0.18	3005.483	15.018	0.012	22.55	
OH26	04/28/93	11:20	0.38	3039.472	33.989	0.011	22.93	

TABLE A-2 (Continued)
BRINE ACCUMULATION DATA TABLE
 Data through December 31, 1993

LOCATION	DATE	TIME	LITERS REMOVED	DAYS	DAYS	LITERS PER DAY	CUMULATIVE	REMARKS
				SINCE 1/1/85	USED FOR CALCULATION		LITERS COLLECTED	
OH26	06/16/93	09:00	0.53	3088.375	48.903	0.011	23.46	
OH26	08/19/93	09:27	0.58	3152.394	0.000	0.000	24.04	Partial evacuation.
OH26	08/20/93	09:06	0.06	3153.379	65.004	0.010	24.10	Combine with 0.58 l from 08-19-93.
OH26	11/09/93	09:39	0.57	3234.402	0.000	0.000	24.67	Partial evacuation.
OH26	11/12/93	11:25	0.36	3237.476	84.097	0.011	25.03	Combine with 0.57 l from 11-09-93.
OH28	08/05/86	14:00	NA	581.583	0.000	0.000	0.00	Approximate date this part of drift excavated.
OH28	04/12/89	14:00	NA	1562.583	981.000	0.000	0.00	Horizontal hole drilled 4/11/89 to 4/12/89.
OH28	04/18/89	10:25	0	1568.434	0.000	0.000	0.00	Device left with approximately 50 centibars suction.
OH28	04/26/89	09:30	0	1576.396	13.813	0.000	0.00	Device left with approximately 50 centibars suction.
OH28	06/05/89	10:30	0.08	1616.438	40.042	0.002	0.08	First time sample recovered. Collection device removed and replaced. Sample saved for chemistry.
OH28	06/20/89	09:30	0.03	1631.396	14.958	0.002	0.11	
OH28	07/06/89	12:00	0	1647.500	16.104	0.000	0.11	Hole dry. Collection device retained vacuum.
OH28	08/09/89	10:45	0	1681.448	33.948	0.000	0.11	Hole dry.
OH28	08/23/89	10:46	0	1695.449	14.001	0.000	0.11	Hole dry.
OH28	10/02/89	11:50	0.05	1735.493	40.044	0.001	0.16	Sample saved for chemistry.
OH28	10/20/89	11:45	0	1753.490	17.997	0.000	0.16	Hole dry.
OH28	11/10/89	11:10	0.07	1774.465	20.975	0.003	0.23	Sample saved for chemistry, sample #867.
OH28	11/29/89	12:48	0	1793.533	19.068	0.000	0.23	Hole dry.
OH28	12/12/89	09:48	0.10	1806.408	12.875	0.008	0.33	Sample saved for chemistry, sample #886.
OH28	04/10/90	09:36	0.14	1925.400	118.992	0.001	0.47	
OH28	04/24/90	08:36	0.18	1939.358	13.958	0.013	0.65	
OH28	05/02/90	09:35	0.01	1947.399	8.041	0.001	0.66	
OH28	05/09/90	09:40	Trace	1954.403	0.000	0.000	0.66	Trace.
OH28	05/16/90	11:38	0.02	1961.485	14.086	0.001	0.68	
OH28	05/31/90	09:33	0.01	1976.398	14.913	0.001	0.69	
OH28	08/07/90	09:42	0.10	2044.404	68.006	0.001	0.79	
OH28	08/10/90	09:10	NA	2047.382	0.000	0.000	0.79	Cleaned, checked, and reinstalled vacuum up to 50 centibars. Checked in one hour. Sampler holding vacuum.
OH28	09/12/90	08:40	0.04	2080.361	35.957	0.001	0.83	
OH28	09/26/90	09:50	0.05	2094.410	14.049	0.004	0.88	
OH28	11/28/90	11:28	0.08	2157.478	63.068	0.001	0.96	
OH28	12/20/90	10:27	0.07	2179.435	21.957	0.003	1.03	
OH28	01/30/91	08:51	0.07	2220.369	40.934	0.002	1.10	
OH28	03/20/91	11:55	0.18	2269.497	49.128	0.004	1.28	
OH28	03/28/91	11:45	0.01	2277.490	7.993	0.001	1.29	
OH28	04/24/91	10:29	0.00	2304.437	26.947	0.000	1.29	Air blowing through tube.
OH28	07/11/91	12:08	0.00	2382.506	78.069	0.000	1.29	Dry.
OH28	07/17/91	11:07	0.00	2388.463	5.957	0.000	1.29	Air blowing through tube.

TABLE A-2 (Continued)
BRINE ACCUMULATION DATA TABLE
 Data through December 31, 1993

LOCATION	DATE	TIME	LITERS REMOVED	DAYS SINCE 1/1/85	DAYS USED FOR CALCULATION	LITERS PER DAY	CUMULATIVE LITERS COLLECTED	REMARKS
OH28	09/25/91	09:56	0.00	2458.414	69.951	0.000	1.29	Air blowing through tube.
OH28	10/23/91	10:27	0.27	2486.435	28.021	0.010	1.56	First time successful collection since 03/20/91. Used 216.94 days and 0.28 liters to calculate flow rate.
OH28	10/31/91	11:36	0.00	2494.483	8.048	0.000	1.56	Dry. No Vacuum. Hole wet at 25 feet.
OH28	11/13/91	10:55	0.02	2507.455	12.972	0.002	1.58	
OH28	12/04/91	11:35	Trace	2528.483	21.028	0.000	1.58	
OH28	01/08/92	11:00	0.00	2563.458	34.975	0.000	1.58	Pumped dry.
OH28	01/30/92	11:45	0.09	2585.490	22.032	0.004	1.67	Brine on push rods @ 25-28 ft. Water pushed out of hole by sampler when removed (lots of brine) sampler checked, Found in working condition
OH28	03/11/92	10:40	0	2626.444	40.954	0.000	1.67	
OH28	04/22/92		0.00	2668.000	41.556	0.000	1.67	
OH28	06/18/92	10:45	0.18	2725.448	57.448	0.003	1.85	
OH28	09/03/92	11:00	0.05	2802.458	77.010	0.001	1.90	Removed collector, repositioned.
OH28	03/25/93	11:25	0.04	3005.476	203.018	****.***	1.94	Liter/day value is > 0.000 and < 0.001.
OH28	11/09/93	09:45	Trace	3234.406	0.000	0.000	1.94	Partial evacuation.
OH45	05/08/89	14:00	NA	1588.583	0.000	0.000	0.00	Approximate date this part of underground core storage room excavated.
OH45	06/15/89	14:00	NA	1626.583	0.000	0.000	0.00	Horizontal hole drilled 6/9/89 to 6/15/89.
OH45	06/23/89	11:00	NA	1634.458	0.000	0.000	0.00	New hole. Installed collection device.
OH45	08/09/89	14:00	0	1681.583	321.930	0.000	0.00	No vacuum. Reinstalled collection device. Hole dry.
OH45	08/23/89	11:30	0.45	1695.479	13.896	0.032	0.45	First time hole sampled. Sample saved for chemistry.
OH45	09/12/89	12:35	0.15	1715.524	20.045	0.007	0.60	Sample saved for chemistry.
OH45	10/02/89	12:15	0.13	1735.510	19.986	0.007	0.73	Sample saved for chemistry.
OH45	10/20/89	11:10	0.11	1753.465	17.955	0.006	0.84	Sample saved for chemistry, sample #852.
OH45	11/10/89	10:20	0.13	1774.431	20.966	0.006	0.97	Sample saved for chemistry, sample #863.
OH45	11/29/89	13:11	0.11	1793.549	19.118	0.006	1.08	Sample saved for chemistry, sample #878.
OH45	12/12/89	10:19	0.08	1806.430	12.881	0.006	1.16	Sample saved for chemistry, sample #889. Sample bubbling.
OH45	01/04/90	11:41	0.14	1829.487	23.057	0.006	1.30	
OH45	01/17/90	11:54	0.08	1842.496	13.009	0.006	1.38	
OH45	01/31/90	11:08	0.01	1856.464	13.968	0.001	1.39	
OH45	02/13/90	10:54	0.01	1869.454	12.990	0.001	1.40	
OH45	02/27/90	12:56	0.11	1883.539	14.085	0.008	1.51	Removed and replaced sampler.
OH45	03/05/90	11:45	0.08	1889.490	5.951	0.013	1.59	
OH45	03/21/90	11:34	Trace	1905.482	0.000	0.000	1.59	Trace.
OH45	04/10/90	10:28	Trace	1925.436	0.000	0.000	1.59	Trace.
OH45	05/02/90	09:12	0.06	1947.383	57.893	0.001	1.65	
OH45	05/09/90	10:03	Trace	1954.419	0.000	0.000	1.65	Trace.
OH45	05/17/90	09:20	0.05	1962.389	0.000	0.000	1.70	
OH45	05/23/90	13:10	0.01	1968.549	21.166	0.003	1.71	

TABLE A-2 (Continued)
BRINE ACCUMULATION DATA TABLE
 Data through December 31, 1993

LOCATION	DATE	TIME	LITERS REMOVED	DAYS SINCE 1/1/85	DAYS USED FOR CALCULATION	LITERS PER DAY	CUMULATIVE LITERS COLLECTED	REMARKS
OH45	06/14/90	10:15	0.01	1990.427	0.000	0.000	1.72	Brine probably left in hole.
OH45	07/17/90	11:58	0.46	2023.499	54.950	0.009	2.18	
OH45	08/07/90	08:50	Trace	2044.368	0.000	0.000	2.18	Trace. Could not sample. Brine probably left in hole.
OH45	08/29/90	12:01	0.27	2066.501	43.002	0.006	2.45	
OH45	09/13/90	10:40	0.02	2081.444	14.943	0.001	2.47	
OH45	10/18/90	10:14	0.05	2116.426	0.000	0.000	2.52	
OH45	02/13/91	12:40	Trace	2234.528	0.000	0.000	2.52	Did not save.
OH45	03/21/91	10:30	0.80	2270.438	188.994	0.004	3.32	Repaired and reinstalled sampler. Used 189 days and 0.85 liters.
OH45	03/28/91	11:21	0.00	2277.473	7.035	0.000	3.32	Air blowing through tube.
OH45	04/10/91	12:15	0.00	2290.510	13.037	0.000	3.32	Dry.
OH45	05/01/91	10:30	0.11	2311.438	20.928	0.005	3.43	
OH45	05/08/91	09:35	0.00	2318.399	6.961	0.000	3.43	Air blowing through tube.
OH45	07/18/91	10:20	0.14	2389.431	71.032	0.002	3.57	
OH45	08/14/91	11:15	0.05	2416.469	27.038	0.002	3.62	
OH45	09/25/91	12:10	0.19	2458.507	42.038	0.005	3.81	
OH45	10/23/91	10:09	0.11	2486.423	27.916	0.004	3.92	
OH45	10/31/91	11:36	0.06	2494.483	8.060	0.007	3.98	
OH45	11/13/91	10:36	0.05	2507.442	12.959	0.004	4.03	
OH45	12/04/91	11:40	0.08	2528.486	21.044	0.004	4.11	
OH45	12/18/91	11:07	0.02	2542.463	13.977	0.001	4.13	
OH45	01/08/92	10:35	0.10	2563.441	20.978	0.005	4.23	
OH45	01/29/92	10:52	0.09	2584.453	21.012	0.004	4.32	
OH45	02/19/92	10:15	0.08	2605.427	20.974	0.004	4.40	
OH45	02/26/92	10:02	Trace	2612.418	6.991	0.000	4.40	
OH45	03/11/92	10:00	0.15	2626.417	13.999	0.011	4.55	
OH45	03/18/92	10:00	0.05	2633.417	7.000	0.007	4.60	
OH45	03/25/92	12:45	0.01	2640.531	7.114	0.001	4.61	
OH45	04/07/92	11:20	0.06	2653.472	12.941	0.005	4.67	
OH45	04/15/92	09:35	Trace	2661.399	7.927	0.000	4.67	
OH45	04/22/92	10:10	Trace	2668.424	7.025	0.000	4.67	
OH45	05/07/92	09:00	Trace	2683.375	14.951	0.000	4.67	
OH45	06/18/92	10:50	0.14	2725.451	42.076	0.003	4.81	
OH45	07/01/92	10:00	0.05	2738.417	12.966	0.004	4.86	
OH45	07/15/92	10:50	0.05	2752.451	14.034	0.004	4.91	
OH45	08/18/92	10:28	0.10	2786.436	33.985	0.003	5.01	
OH45	09/02/92	10:30	0.15	2801.438	15.002	0.010	5.16	
OH45	09/24/92	09:30	0.07	2823.396	21.958	0.003	5.23	
OH45	10/21/92	14:00	0.15	2850.583	27.187	0.006	5.38	
OH45	01/07/93	09:35	0.25	2928.399	77.816	0.003	5.63	
OH45	01/28/93	11:20	0.13	2949.472	21.073	0.006	5.76	
OH45	03/25/93	10:45	0.05	3005.448	55.976	0.001	5.81	
OH45	04/28/93	11:30	0.19	3039.479	34.031	0.006	6.00	
OH45	06/16/93	08:43	0.15	3088.363	48.884	0.003	6.15	
OH45	08/19/93		0.20	3152.000	63.637	0.003	6.35	
OH45	11/12/93	11:09	0.24	3237.465	85.465	0.003	6.59	

TABLE A-2 (Continued)
BRINE ACCUMULATION DATA TABLE
 Data through December 31, 1993

LOCATION	DATE	TIME	LITERS REMOVED	DAYS	DAYS	LITERS PER DAY	CUMULATIVE	REMARKS
				SINCE 1/1/85	USED FOR CALCULATION		LITERS COLLECTED	
OH46	05/08/89	14:00	NA	1588.583	0.000	0.000	0.00	Approximate date this part of underground core storage room excavated.
OH46	06/20/89	14:00	NA	1631.583	0.000	0.000	0.00	Downhole drilled 6/16/89 to 6/20/89.
OH46	07/06/89	11:30	NA	1647.479	0.000	0.000	0.00	First day of observation for hole, blown dry.
OH46	07/25/89	10:48	0.28	1666.450	77.867	0.004	0.28	First time hole sampled. Sample yellow with wood chips and other debris. Hydrocarbon odor (diesel lubricant?).
OH46	08/16/89	10:05	0.68	1688.420	21.970	0.031	0.96	Sample saved for chemistry.
OH46	09/12/89	12:35	0.47	1715.524	27.104	0.017	1.43	Sample saved for chemistry.
OH46	10/02/89	12:30	0.05	1735.521	0.000	0.000	1.48	Sample saved for chemistry. Some brine probably left in hole.
OH46	10/20/89	11:10	0.57	1753.465	37.941	0.016	2.05	Sample saved for chemistry, sample #853. Combined with 0.05 liters from 10-02-89. Used 0.62 liters for calculation.
OH46	11/10/89	10:30	0.68	1774.438	20.973	0.032	2.73	Sample saved for chemistry, sample #865.
OH46	11/29/89	13:15	0.53	1793.552	19.114	0.028	3.26	Sample saved for chemistry, sample #879.
OH46	12/12/89	10:20	0.46	1806.431	12.879	0.036	3.72	Sample saved for chemistry, sample #890.
OH46	01/04/90	11:44	0.45	1829.489	23.058	0.020	4.17	
OH46	01/17/90	11:58	0.25	1842.499	13.010	0.019	4.42	
OH46	01/31/90	11:12	0.25	1856.467	13.968	0.018	4.67	
OH46	02/13/90	11:16	0.22	1869.469	13.002	0.017	4.89	
OH46	02/27/90	13:10	0.27	1883.549	14.080	0.019	5.16	Brine probably left in hole.
OH46	03/05/90	11:54	0.27	1889.496	5.947	0.045	5.43	
OH46	03/21/90	11:34	0.13	1905.482	15.986	0.008	5.56	Brine probably left in hole.
OH46	04/11/90	10:33	0.32	1926.440	20.958	0.015	5.88	
OH46	05/02/90	09:10	0.25	1947.382	20.942	0.012	6.13	Brine probably left in hole.
OH46	05/08/90	10:05	0.15	1953.420	6.038	0.025	6.28	
OH46	05/17/90	09:30	0.14	1962.396	8.976	0.016	6.42	
OH46	05/23/90	13:30	0.10	1968.563	6.167	0.016	6.52	
OH46	06/14/90	10:01	0.32	1990.417	21.854	0.015	6.84	
OH46	06/28/90	11:06	0.20	2004.463	14.046	0.014	7.04	
OH46	07/17/90	11:50	0.30	2023.493	19.030	0.016	7.34	
OH46	07/25/90	10:50	0.15	2031.451	7.958	0.019	7.49	
OH46	08/07/90	08:50	0.19	2044.368	12.917	0.015	7.68	
OH46	08/16/90	10:30	0.17	2053.438	9.070	0.019	7.85	
OH46	08/22/90	11:05	0.11	2059.462	6.024	0.018	7.96	
OH46	08/29/90	11:45	0.11	2066.490	7.028	0.016	8.07	
OH46	09/05/90	11:04	0.12	2073.461	6.971	0.017	8.19	
OH46	09/13/90	10:42	0.12	2081.446	7.985	0.015	8.31	
OH46	09/28/90	10:10	0.22	2096.424	14.978	0.015	8.53	
OH46	10/18/90	09:52	0.26	2116.411	19.987	0.013	8.79	
OH46	02/13/91	12:50	0.74	2234.535	118.124	0.006	9.53	
OH46	02/27/91	11:05	0.55	2248.462	13.927	0.039	10.08	
OH46	03/20/91	13:37	0.58	2269.567	21.105	0.027	10.66	

TABLE A-2 (Continued)
BRINE ACCUMULATION DATA TABLE
 Data through December 31, 1993

LOCATION	DATE	TIME	LITERS REMOVED	DAYS SINCE 1/1/85	DAYS USED FOR CALCULATION	LITERS PER DAY	CUMULATIVE LITERS COLLECTED	REMARKS
OH46	03/28/91	11:21	0.19	2277.473	7.906	0.024	10.85	
OH46	04/10/91	12:15	0.15	2290.510	13.037	0.012	11.00	
OH46	04/17/91	11:21	0.28	2297.473	6.963	0.040	11.28	
OH46	05/01/91	10:30	0.18	2311.438	13.965	0.013	11.46	
OH46	05/08/91	08:59	0.09	2318.374	6.936	0.013	11.55	
OH46	05/15/91	10:48	0.09	2325.450	7.076	0.013	11.64	
OH46	06/12/91	09:45	0.29	2353.406	27.956	0.010	11.93	
OH46	06/19/91	15:57	0.10	2360.665	7.259	0.014	12.03	
OH46	06/26/91	10:00	0.10	2367.417	6.752	0.015	12.13	
OH46	07/11/91	10:20	0.20	2382.431	15.014	0.013	12.33	
OH46	07/17/91	11:04	0.08	2388.461	6.030	0.013	12.41	
OH46	07/30/91	11:00	0.16	2401.458	12.997	0.012	12.57	
OH46	08/08/91	09:50	0.13	2410.410	8.952	0.015	12.70	
OH46	08/14/91	10:45	0.08	2416.448	6.038	0.013	12.78	
OH46	08/28/91	11:11	0.17	2430.466	14.018	0.012	12.95	
OH46	09/18/91	09:40	0.26	2451.403	20.937	0.012	13.21	
OH46	09/25/91	12:35	0.15	2458.524	7.121	0.021	13.36	
OH46	10/16/91	10:45	0.22	2479.448	20.924	0.011	13.58	
OH46	10/23/91	10:10	0.12	2486.424	6.976	0.017	13.70	
OH46	10/31/91	11:30	0.10	2494.479	8.055	0.012	13.80	
OH46	11/06/91	12:10	0.09	2500.507	6.028	0.015	13.89	
OH46	11/13/91	10:36	0.08	2507.442	6.935	0.012	13.97	
OH46	11/27/91	10:11	0.14	2521.424	13.982	0.010	14.11	
OH46	12/04/91	11:45	0.11	2528.490	7.066	0.016	14.22	
OH46	12/18/91	10:25	0.15	2542.434	13.944	0.011	14.37	
OH46	01/08/92	10:35	0.23	2563.441	21.007	0.011	14.60	
OH46	01/29/92	10:53	0.22	2584.453	21.012	0.010	14.82	
OH46	02/12/92	09:35	0.18	2598.399	13.946	0.013	15.00	
OH46	02/19/92	10:15	0.05	2605.427	7.028	0.007	15.05	
OH46	02/26/92	10:04	0.08	2612.419	6.992	0.011	15.13	
OH46	03/11/92	10:00	0.05	2626.417	13.998	0.004	15.18	
OH46	03/18/92	10:05	0.08	2633.420	7.003	0.011	15.26	
OH46	03/25/92	12:45	0.16	2640.531	7.111	0.023	15.42	
OH46	04/01/92	10:50	0.08	2647.451	6.920	0.012	15.50	
OH46	04/07/92	11:25	0.08	2653.476	6.025	0.013	15.58	
OH46	04/15/92	09:35	0.10	2661.399	7.923	0.013	15.68	
OH46	04/22/92	10:20	0.08	2668.431	7.032	0.011	15.76	
OH46	05/07/92	09:00	0.15	2683.375	14.944	0.010	15.91	
OH46	05/27/92	10:00	0.22	2703.417	20.042	0.011	16.13	
OH46	06/18/92	10:55	0.24	2725.455	22.038	0.011	16.37	
OH46	06/25/92	10:39	0.10	2732.444	6.989	0.014	16.47	
OH46	07/01/92	10:00	0.07	2738.417	5.973	0.012	16.54	
OH46	07/08/92		0.08	2745.000	6.583	0.012	16.62	
OH46	07/15/92	10:50	0.09	2752.451	7.451	0.012	16.71	
OH46	07/22/92	11:45	0.08	2759.490	7.039	0.011	16.79	
OH46	08/04/92	10:05	0.15	2772.420	12.930	0.012	16.94	
OH46	08/18/92	10:28	0.15	2786.436	14.016	0.011	17.09	

TABLE A-2 (Continued)
BRINE ACCUMULATION DATA TABLE
 Data through December 31, 1993

LOCATION	DATE	TIME	LITERS REMOVED	DAYS SINCE 1/1/85	DAYS USED FOR CALCULATION	LITERS PER DAY	CUMULATIVE LITERS COLLECTED	REMARKS
OH46	09/02/92	10:35	0.18	2801.441	15.005	0.012	17.27	
OH46	09/24/92	09:32	0.01	2823.397	21.956	****.***	17.28	Liters/day value is > 0.000 and < 0.001 (0.4E-03).
OH46	10/21/92	14:05	0.50	2850.587	27.190	0.018	17.78	
OH46	10/28/92	09:35	0.06	2857.399	6.812	0.009	17.84	
OH46	11/11/92	12:50	0.15	2871.535	14.136	0.011	17.99	
OH46	12/09/92	13:30	0.28	2899.563	28.028	0.010	18.27	
OH46	12/16/92	10:40	0.04	2906.444	6.881	0.006	18.31	
OH46	01/07/93	09:40	0.23	2928.403	21.959	0.010	18.54	
OH46	01/13/93	10:10	0.06	2934.424	6.021	0.010	18.60	
OH46	01/28/93	11:25	0.13	2949.476	15.052	0.009	18.73	
OH46	03/25/93	10:45	0.49	3005.448	55.972	0.009	19.22	
OH46	04/28/93	11:30	0.33	3039.479	34.031	0.010	19.55	
OH46	06/16/93	08:43	0.33	3088.363	48.884	0.007	19.88	
OH46	08/19/93		0.45	3152.000	63.637	0.007	20.33	
OH46	11/12/93	11:09	0.42	3237.465	85.465	0.005	20.75	

THIS PAGE INTENTIONALLY LEFT BLANK

APPENDIX B
GRAPHS OF BRINE ACCUMULATION DATA

THIS PAGE INTENTIONALLY LEFT BLANK

APPENDIX B

GRAPHS OF BRINE ACCUMULATION DATA

This appendix contains graphs of data presented in Appendix A for selected locations. As described in Deal and Case (1987), much of the variability in the quantity of brine collected resulted from limitations of the collection techniques, rather than variations in the actual inflow of brine from bedrock at the collecting locations. As a result, plotting of the inflow data from the data tables (Appendix A) results in an irregular plot that implies variations in inflow which, in fact, do not exist. An 11-point moving average was used to smooth the line. The smoothed data reflect trends in the body of the curve that are representative of the brine seepage rates, while still showing variations that are probably the result of collection techniques.

At the beginning and end of each curve, moving average smoothing projects the calculated trend. As a result, initial and ending values tend to be distorted by the 11-point moving average smoothing program. A "step-down" moving average was used for the data points at the beginning and end of the curve to correct the distortion. The "step-down" moving average involves stepping down from an 11-point average to a 9-point, 7-point, 5-point and a 3-point average at both ends of the line, utilizing the actual data for the last point. Additional discussion of the collection and data handling is provided in Deal and Case (1987).

THIS PAGE INTENTIONALLY LEFT BLANK

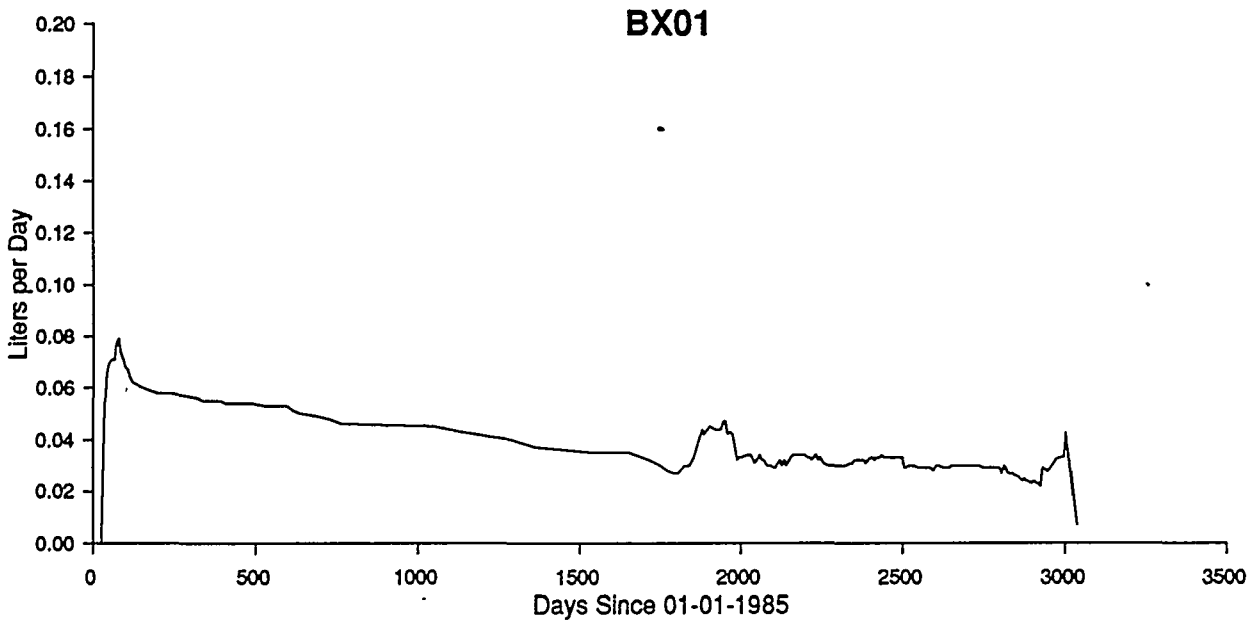
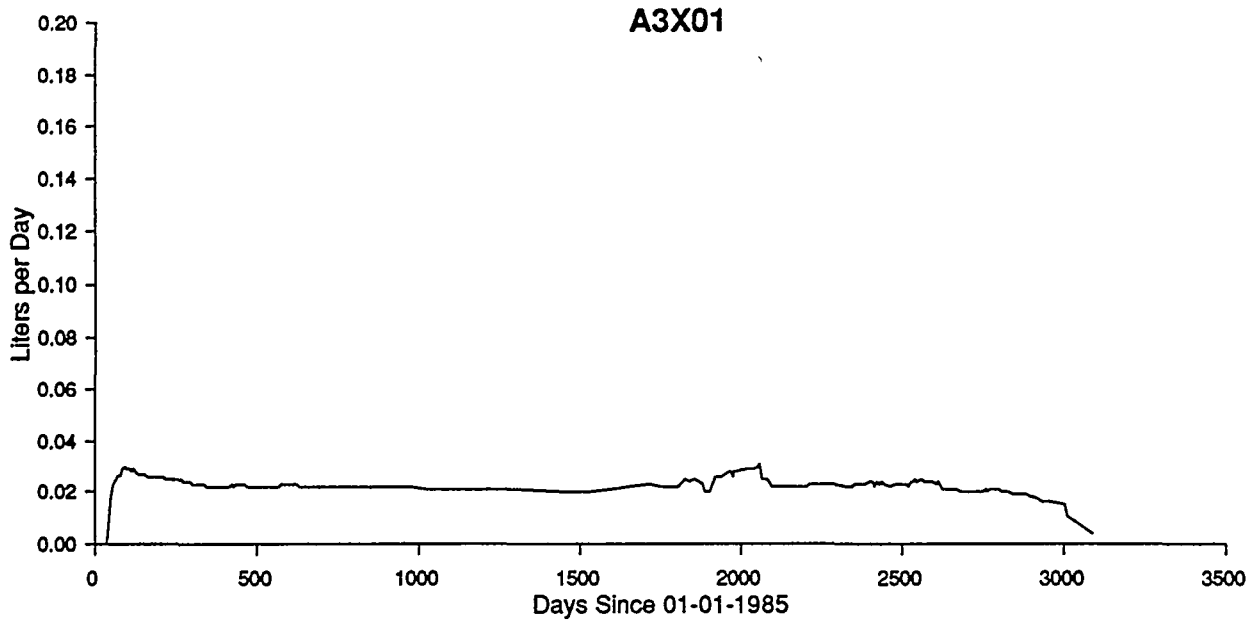

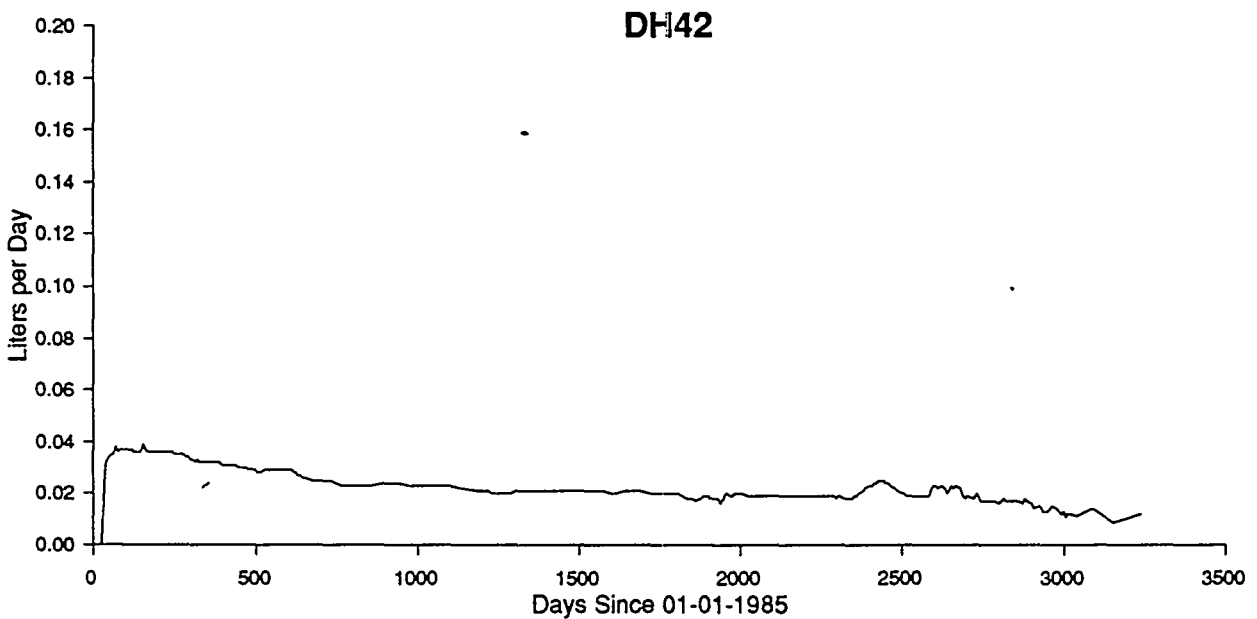
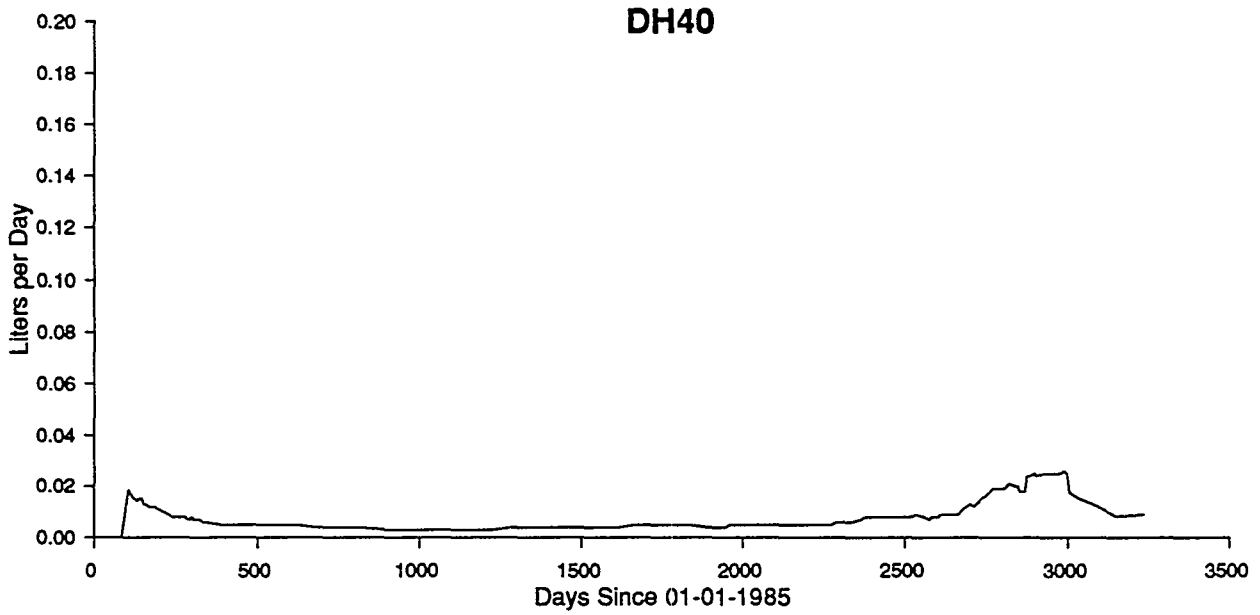

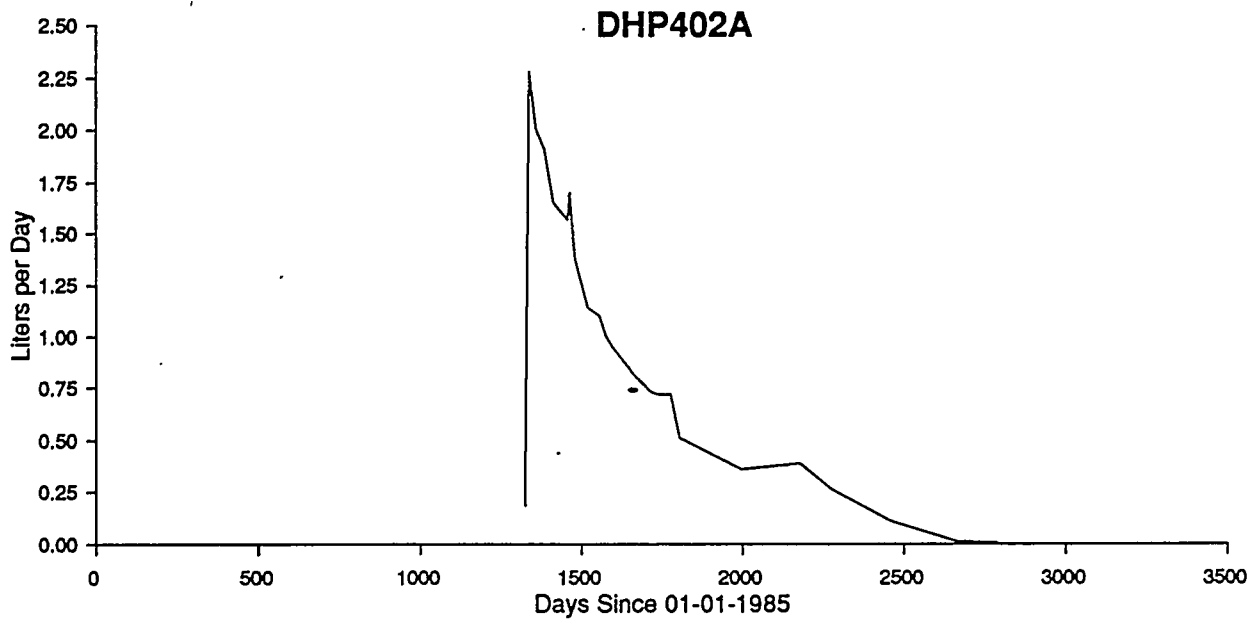
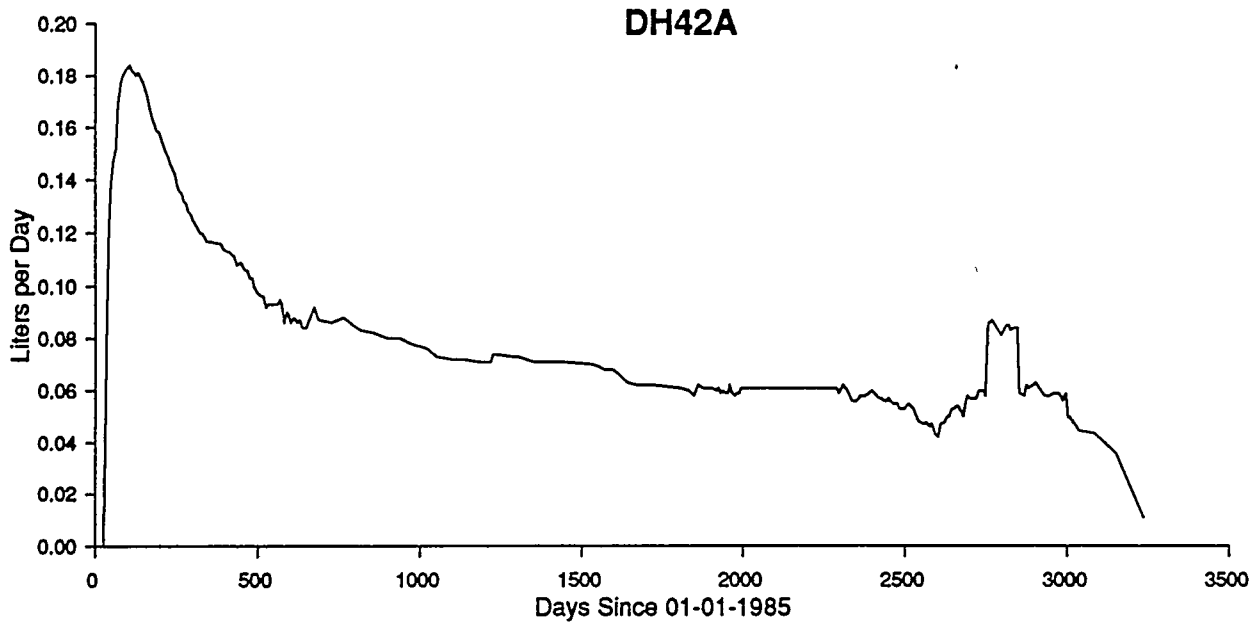

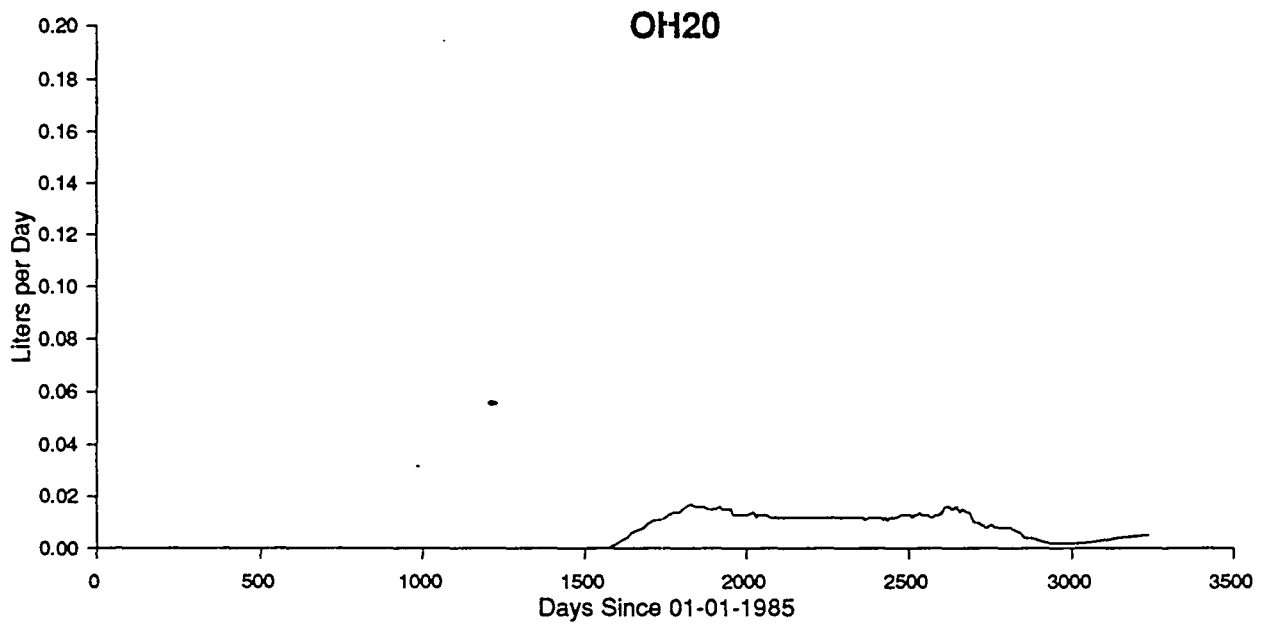
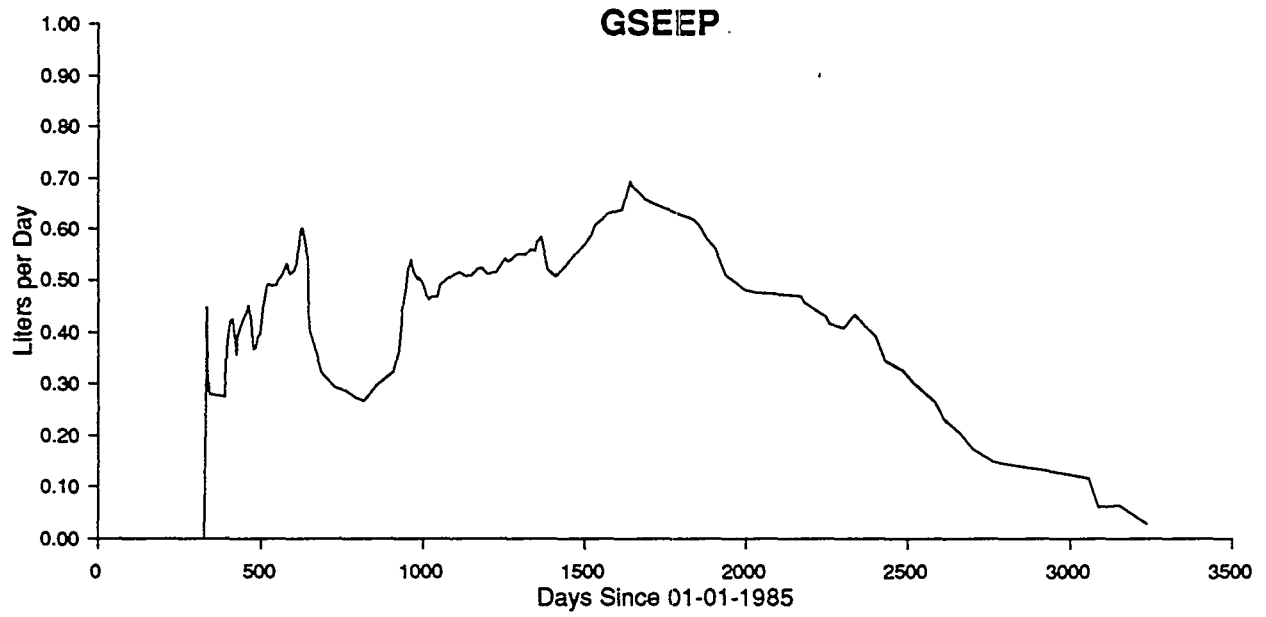

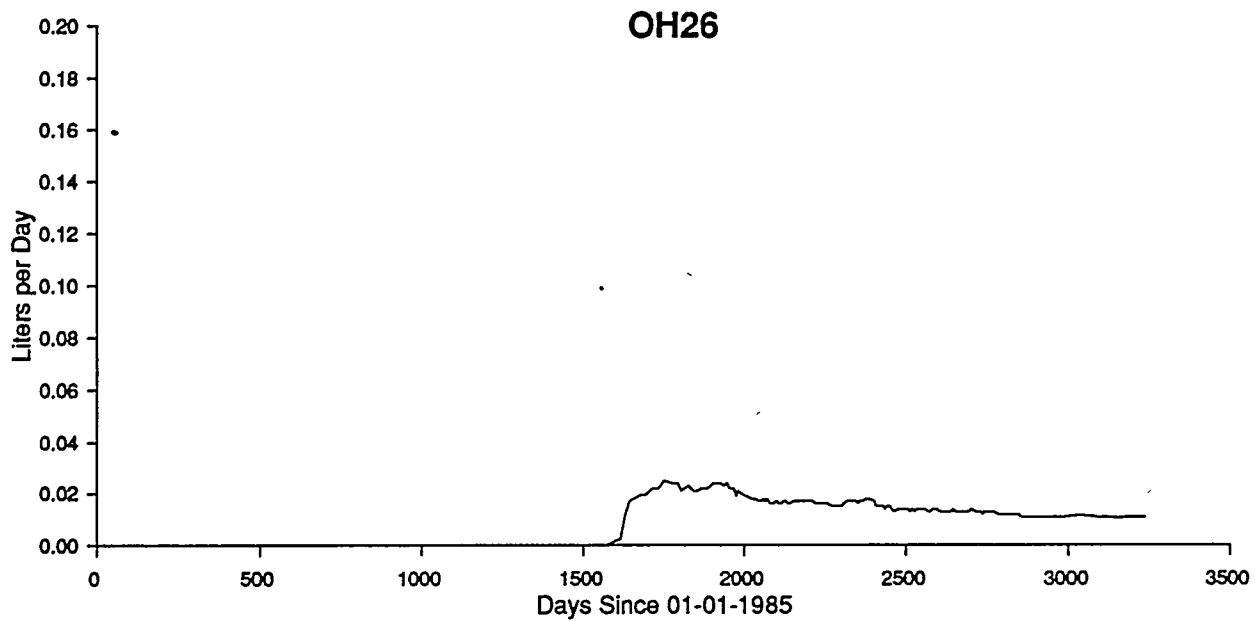
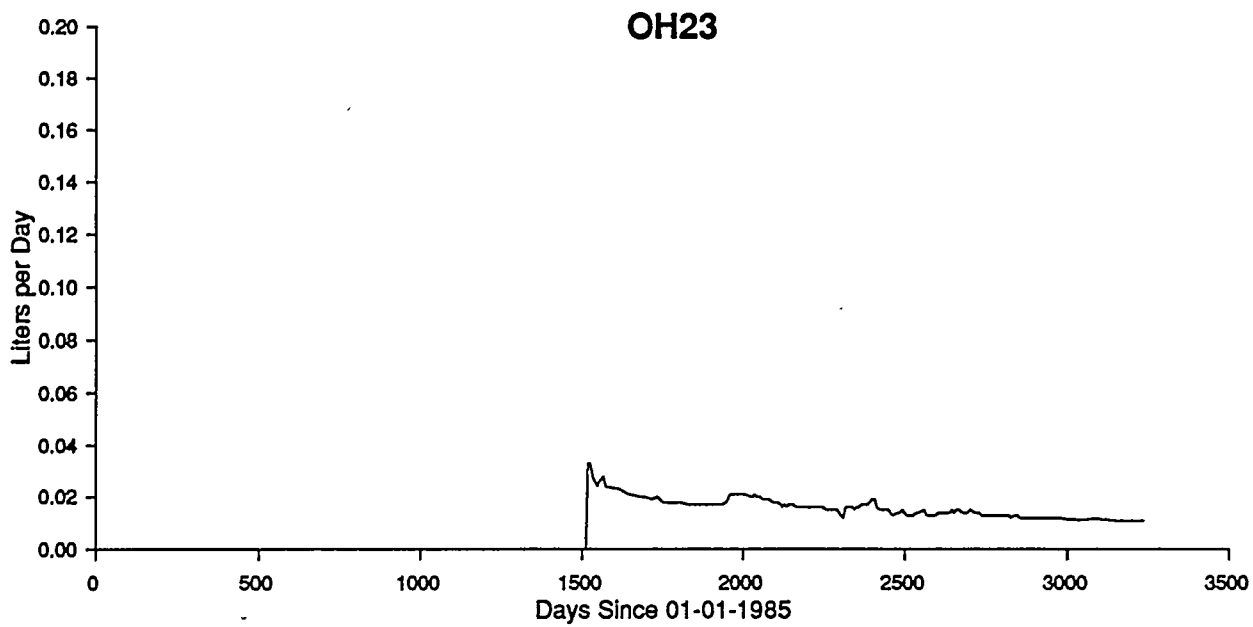

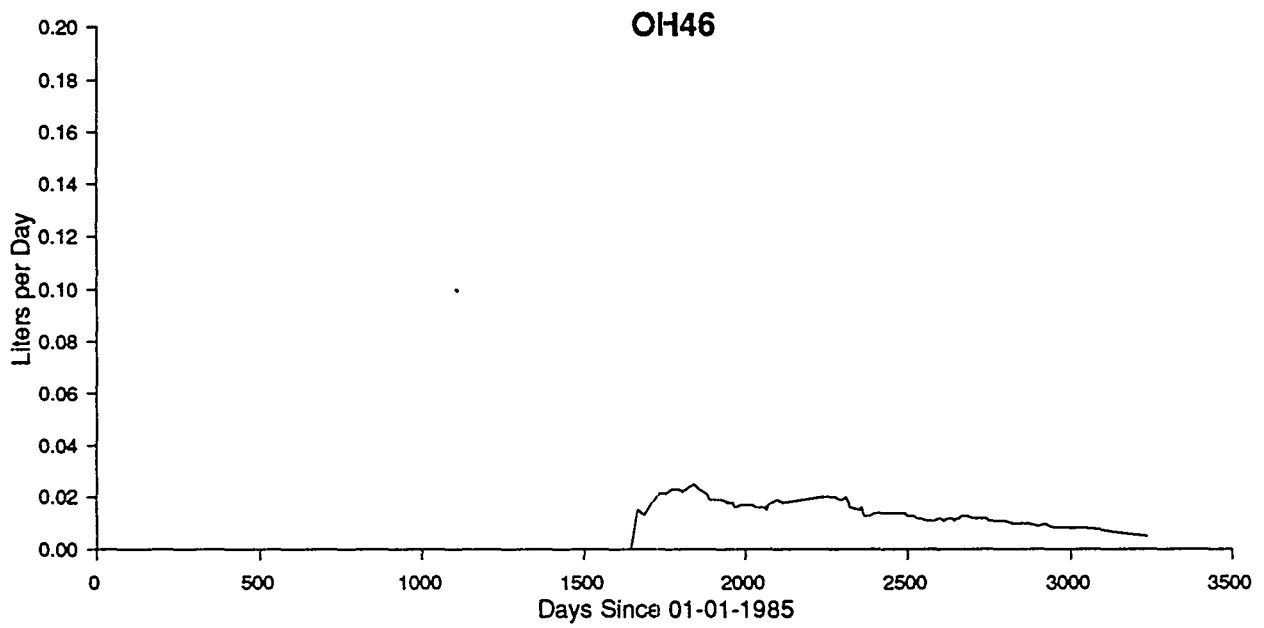
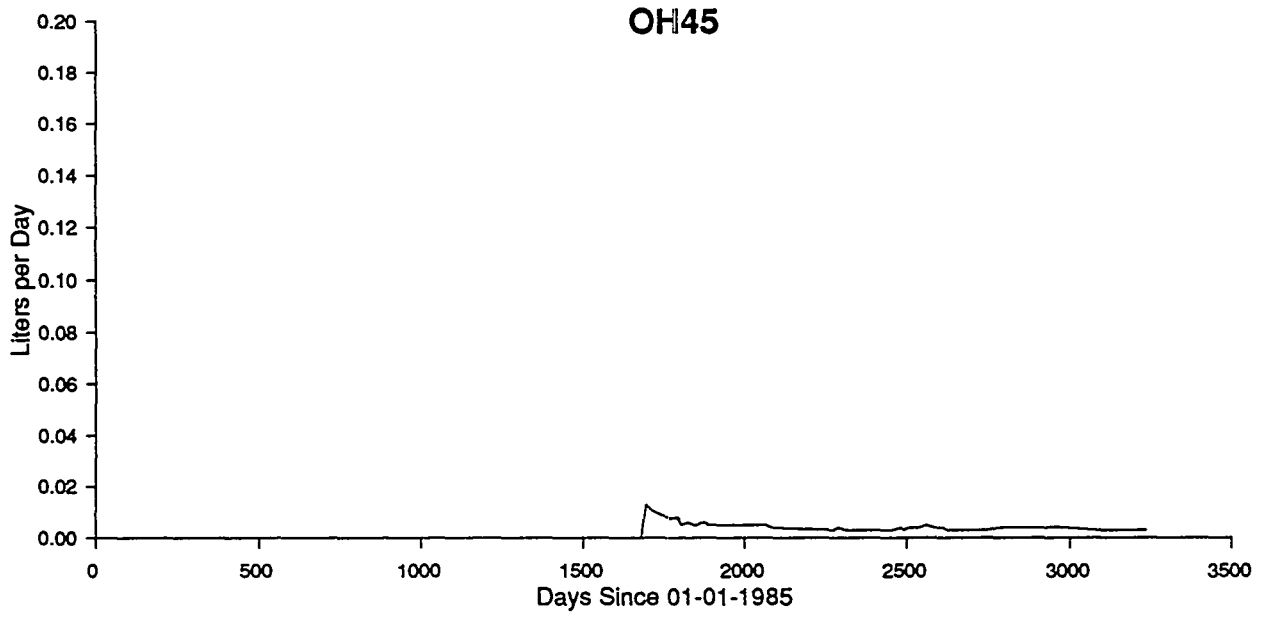

APPENDIX C
AIR INTAKE SHAFT INSPECTION

THIS PAGE INTENTIONALLY LEFT BLANK

Table of Contents

C.1.0 General Observations	C-2
C.2.0 Specific Observations	C-3
C.3.0 Discussion	C-6
C.4.0 Summary	C-7
C.5.0 Recommendations	C-7
C.6.0 References to Appendix C	C-8

THIS PAGE INTENTIONALLY LEFT BLANK

AIR INTAKE SHAFT INSPECTION

Surfaces of excavated areas for the Waste Isolation Pilot Plant (WIPP) have been observed to develop salt encrustations from weeps in some locations (TSC-D'Appolonia, 1983; Deal and others, 1989). These weeps develop salt encrustations over a period of time, if flow is sufficient, and then dry up and cease to flow within periods ranging from hours to a few years (Deal and others, 1989). Similar phenomena are observed within some potash mine areas that are also in the Salado Formation in the vicinity of WIPP (Deal and Case, 1987, Section 3.2).

The source of the brine, the process of fluid flow, and the rate and volume of fluid flow to repository panels are significant factors in assessing the volume of water that will accumulate within the panels. The water volume is an important parameter for calculating gas generation during breakdown of waste; gas pressure might be sufficient to fracture the surrounding rock and breach containment (SNL/NM, 1992). Deal and Bills (1994) and Deal and others (1994) have concluded that empirical data from 11 years of observations, as well as some simplified modeling, indicate that fluid flow will be limited in duration and volume. They conclude that the brine will be a small fraction of that required to corrode metal and to generate gas pressures high enough to fracture the surrounding rock. Because of this, it is appropriate to examine the evidence developed empirically about the weeps, determine limits to inferences based on this data, and seek any further evidence bearing on interpretations already provided.

The Air Intake Shaft (AIS) at the WIPP provides a different perspective on the distribution and development of weeps within the Salado Formation. The underground workings reveal a significant horizontal area within a fairly narrow stratigraphic range and at relatively constant depth. The underground areas open to visual observation are predominantly halite beds. Sulfate interbeds are exposed in only a few locations and have been altered by deformation in the disturbed rock zone (DRZ). It is difficult to accurately determine the undisturbed hydrologic properties of the sulfate beds from those exposures. The AIS is a vertical, circular shaft with reasonable access to the beds from the repository level to near the top of the Salado Formation. Sulfate marker beds, clay-rich units, and halitic beds with differing minor components are observable at different depths. Although a DRZ has formed around the shaft, the extensive fracturing that characterizes the DRZ around the rectangular, horizontal WIPP excavations (Appendix E, Figure E-2-1) does not exist.

A portion of the shaft wall was cleaned with high-pressure water during 1989 and was then allowed to dry. The AIS was mapped in considerable detail based on the cleaned section (Holt and Powers, 1990). Some sections of the shaft were noted to be yielding some fluid during mapping. The cleaned and mapped portion of the shaft was observed during recent inspections to have remained relatively clean and well-exposed, providing the opportunity to compare the present surface with that mapped during 1989. (For consistency with that report, English units are used in this appendix.)

On July 19, 1994, an initial assessment of the development of the weeps in the AIS was made from the man cage. The units were viewed at inspection speed on the down trip to the repository level, confirming that the south shaft wall was still well-exposed. Significant marker beds were identified and weeps were found to be present. Salt encrustations were noted on the stratigraphic log of the shaft mapping (Holt and Powers, 1990). A more detailed examination was performed during the ascent.

All observations were made from the confines of the man cage, approximately centered in the shaft and about 9 ft from the shaft wall. Lighting was provided by battery powered miner's lamps and a flashlight.

C.1.0 General Observations

A strip ranging from approximately 5 to 20 ft wide along the south side of the AIS was cleaned with high-pressure water and allowed to dry before the AIS was mapped during 1989 (Holt and Powers, 1990). This strip remains in good condition for observing geologic features nearly five years later, although the surface has altered somewhat under the intake of air varying in temperature and humidity.

Salt encrustations are much more common below the depth of 1,500 ft in the shaft, approximately the midpoint of the exposed Salado in the AIS. Only a few units above 1,500 ft show that weeps have existed, though Marker Bed (MB) 103 (near the top of the Salado) was the only bed observed to have a wet surface at the time of this survey. The observations do not differentiate between zones where weeps have ceased and zones where there might still be seepage under the salt encrustation.

As noted in some of the specific comments below, many of the encrustations appear to emanate from or are closely associated with contacts between units where Holt and Powers (1990) inferred exposure surfaces of Permian age, based on the compositions, sedimentary

features, and textures of the units underlying the contact. The bulk of the encrustations are also closely associated with argillaceous units.

C.2.0 Specific Observations

The specific observations of salt encrustations in the AIS have been summarized (see Table C-2-1) for reference relative to the original mapping (Holt and Powers, 1990). There is a minor difference in depth below approximately 2,000 ft between the present depth markers and the original depth reference for mapping. Except as noted, the depths in this report correspond to the original mapping depth to aid in relating them to the stratigraphy presented from the mapping. Specific examples of features are described briefly; they are ordered here by increasing depth.

MB 103 (1,029 ft) displays the most significant salt encrustations for any sulfate marker bed within the AIS (Figure C-2-1). The weeps were restricted to a zone about 1 ft thick that is dolomitic, overlies a claystone, and was observed to be wet during inspection. The same zone was yielding fluid during the 1989 mapping. Rock bolts from the argillaceous halite, below the marker bed and claystone, at a depth of approximately 1,030 ft were also wet.

The lower 5-6 ft of the Vaca Triste Sandstone Member (1,342—1,348 ft) displays significant encrustations, many around the heads of rock bolts used to hold screen in place (Figures C-2-2 and C-2-3). The upper 2 ft (see Figure C-2-2) reveals sedimentary features, dish-shaped structures, and soft-sediment deformation consistent with synsedimentary remobilization of halite in a mud pan. This zone is also halitic and shows no evidence of weeps (see Figure C-2-2). Encrustations are large in the lower part (see Figure C-3).

Many of the marker beds show no encrustations associated with weeps, as illustrated by the Union Anhydrite (1,529—1,535 ft) (Figure C-2-4). A distinctive argillaceous unit from about 1,673 to 1,676 ft has produced a number of small encrustations within the unit as well as at and slightly above the upper surface (see Figure C-2-5). Subaqueous primary halite overlies the unit. The halite immediately above the argillaceous halite should be examined at close range to more precisely determine the relationship of weeps to halite. In most areas, high-purity halite shows no encrustations.

A series of stratigraphically controlled encrustations (see Figure C-2-6) from a zone at a depth of approximately 1,767 to 1,776 ft is related to several exposure surfaces over that interval.

During original mapping, some of these zones, as well as others nearby, were observed to have some brine seeps.

Within Figure C-6, two zones (one at approximately 1,770 ft and one from 1,775 ft to approximately 1,777 ft) do not seem to have yielded any fluid or to have developed any encrustations. From the descriptions (Holt and Powers, 1990), these two zones, or beds, differ from adjacent zones in two ways: a higher content of clay and a higher proportion of "podular" textures. These areas may also warrant closer examination from the work platform or galloway.

Clay minerals distributed throughout the uppermost deposits of an exposure surface seem to be the significant control for a number of the intervals with encrustations. The exposure surface at the 1,825-ft depth (Figure C-2-7) is overlain by halite still exhibiting some primary fluid inclusion zones. The surface itself developed some of the larger and deeper (some to 10 ft) syndimentary dissolution pipes within the Salado Formation as the penecontemporaneous water table dropped below the exposed surface. The clays do not occur in large proportions under this surface, but they are greater than in underlying or overlying units.

There is very little association of encrustations with marker beds composed mostly of polyhalite. A thin (less than 1 ft) unit of mixed polyhalite and halite (see Figure C-2-8) at a depth of approximately 1,845 ft) overlying an exposure surface developed some significant encrustations. Minor encrustations also developed in the slightly polyhalitic halite overlying this unit. Because the polyhalite-halite bed appeared slumped and contorted, it may be that clays are significant in the unit, though not noted during mapping. Solution pipes with collapse textures underlie this bed and developed small encrustations from collapse material.

Claystones and argillaceous halite underlying several of the marker beds have developed encrustations. The gray claystone (see Figure C-2-9) underlying MB 131 shows this stratigraphic control. The exposure surface at approximately 1,867 ft, shown near the bottom of Figure C-2-9, also developed a line of encrustations similar to other exposure surfaces. As in other parts of the shaft, it is notable that rock bolts within approximately a foot of the upper line of encrustations did not develop observable evidence of weeps.

An unnamed anhydrite at approximately 1,940 ft (see Figure C-2-10) shows encrustations developed at, and possibly slightly above, the underlying claystone. Rock bolts within the upper part of the anhydrite indicate that some weeps have developed. This unit should be

examined more closely for cracking as well as for lithologic control of the weeps. The basal part of Figure C-2-10 shows possible minor weeps originating from the argillaceous halite underlying the claystone.

MB 134, at a depth from 1,956 to 1,967 ft, appears to have developed 2 or 3 isolated weeps within the upper few feet of the unit (see Figure C-2-11). These are unusual among the observed encrustations in the AIS for two reasons: they are within a thick anhydrite, and they are isolated. This entire unit should be carefully examined for evidence of fractures and controls on the weeps.

The claystone at the base of MB 135 appears to control weep locations, as do some other marker beds (Figure C-2-12 at a depth of approximately 1,985 ft). Some encrustations developed above MB 135 from clay-filled synsedimentary pits or caves (Figure C-2-12) (Holt and Powers, 1990). The anhydrite in MB 135 should be more carefully examined for evidence of fractures.

The major exposure surface at approximately 1,995 ft (Figure C-2-13), as well as secondary surfaces below that, controls the location of many of the encrustations in that zone. In addition to discrete surfaces, the clay content increases in the upper 5 ft of this zone of weeps. The overlying, relatively pure halite did not develop weeps, as in many similar sequences throughout the AIS.

From a depth of about 2,075 to nearly 2,100 ft, a series of stratigraphically controlled encrustations developed along mapped exposure surfaces (Figure C-2-14). The clay content generally increases upward toward the exposure surface, and the overlying halite is relatively pure with remains of primary fluid inclusion zones in some halite.

The base of MB 138 (Figure C-2-15) shows weeps similar to some other sulfate beds. It is the closest such claystone-sulfate unit above the repository horizon to develop encrustations. "Anhydrite a," at an original mapping depth of approximately 2,123 to 2,124 (2,121 to 2,122 ft according to new depth-marker signs) shows a visible fracture but no evidence of seepage.

Discontinuous small encrustations developed along and above the exposure surface (referred to as clay I in reference stratigraphy for rock mechanics) originally mapped at approximately 2,113 ft (Figure C-2-16). Above the more significant exposure surface, the halite is thinly

bedded with anhydrite stringers indicating minor exposure. These encrustations are the closest observed to the repository horizon.

C.3.0 Discussion

The most common denominator for the salt encrustations observed in the AIS appears to be stratigraphic discontinuities interpreted by Holt and Powers (1990) as produced by a period of exposure during the Permian Age before deposition of the overlying sediment. It could also be reasonably argued that clay content is the common denominator. Exposure surfaces and increasing clay content upward in a depositional cycle are associated. Nonetheless, the mere presence of either an exposure surface or a surface of clay does not mean that a weep will form; most do not develop weeps.

At this time, there is insufficient evidence to draw conclusions from the AIS as to whether the units that developed salt encrustations might do so if intercepted at another location. Various locations underground at WIPP do produce weeps within the same stratigraphic units; therefore, it is suspected that a unit producing weeps in the AIS will be prone to produce weeps if intercepted elsewhere. This has not been demonstrated by observation. Nor can it be demonstrated that a shaft some distance from the AIS would only produce weeps from the exact same stratigraphic intervals. It is expected that any intercept through these units would produce weeps that preferentially, but not uniquely, are associated with exposure surfaces and attendant argillaceous halite.

Claystones under some sulfate beds do produce weeps. These are more common at greater depth. Some might also be interpreted to overlie exposure surfaces. By inspection, it appears that claystones underlying sulfate beds less than 2 ft thick more frequently produce weeps than those underlying thicker sulfate beds.

MB 103 has the most significant weeps of any sulfate unit in the AIS, and it also has a wet surface. In contrast, "anhydrite a" is visibly fractured parallel to bedding but appears not to have developed any weeps. This observation limits the amount of fluid available from the unit to that which might have flowed before cleaning and mapping.

In contrast, MB 103 persisted with flow after this period of cleaning and mapping. As the uppermost unit yielding weeps, unloading may be more of a factor, but it must also be noted that other marker beds above and below MB 103 did not similarly yield brine.

C.4.0 Summary

The AIS intercepts a variety of evaporite lithologies and bedding relationships. A number of these units have developed salt encrustations over the five years since a strip was cleaned and mapped.

Encrustations are more abundant below a depth of approximately 1,500 ft, about the midpoint of the exposed Salado Formation in the AIS. The salt encrustations are frequently, but not uniquely, associated with Permian age exposure surfaces and related argillaceous halite. Claystones under a few sulfate beds in the lower half also yielded brine. MB 103, near the top of the exposed Salado, has much more salt encrustation than any other marker bed, and it shows a small surface that is observably wet now. Most of the sulfate beds, especially polyhalitic units, show no weeps or encrustations.

Observations were made from approximately 9 ft away. The encrustations all appeared to be dry.

C.5.0 Recommendations

It is recommended that some additional, closer, observations of the AIS weep occurrences be performed to supplement the preliminary data reported here. Selected stratigraphic intervals should be examined in detail from the galloway to confirm the stratigraphic and textural relationships between encrustations and previous mapping.

A limited, two-part program in the AIS to confirm the preliminary observations is recommended. This should be within the capabilities of on-site geotechnical personnel, especially if trained as indicated above; outside observers can confirm information, if necessary. The first phase is to document the encrustations in considerably more detail by demonstrating very specific textural and stratigraphic relationships to the encrustations. Scaled photographic records should also be included.

During the first phase, some areas of encrustations should be removed within carefully documented and marked areas. The samples should be preserved for possible analysis pending further observations. Within selected stratigraphic intervals, part of the encrustations may be removed to compare any future precipitation with current encrustations. The main purpose of scraping the areas is to determine if some weeps might still be active and would develop again.

The second phase is a modest program of reinspections to determine if weeping is continuing where the encrustations had been removed, as well as a general survey of the shaft for any other evidence of renewed weeps. The initial inspections should be within a few weeks, at most, to not miss small amounts of weeping. Within a year, a few inspections should reveal any renewed activity. If there are additional weeps, the program of observation can be reevaluated.

C.6.0 References to Appendix C

Deal, D. E., and R. A. Bills, 1994, "Conclusions After Eleven Years of Studying Brine at the Waste Isolation Pilot Plant," *Waste Management '94, Tucson, Arizona, March 2, 1994*, IT Corporation, Albuquerque, New Mexico, and U.S. Department of Energy, Carlsbad, New Mexico.

Deal, D. E., and J. B. Case, 1987, "Brine Sampling and Evaluation Program, Phase I Report," *DOE-WIPP 87-008*, prepared for the U.S. Department of Energy by IT Corporation and Westinghouse Electric Corporation, Carlsbad, New Mexico, 163 pp.

Deal, D. E., R. M. Holt, J. M. Melvin, and S. M. Djordjevic, 1994, "Calculation of Brine Seepage from Anhydrite Marker Bed 139 into a Waste Storage Room at the Waste Isolation Pilot Plant," *DOE-WIPP 94-007*, Westinghouse Electric Corp., Carlsbad, New Mexico.

Deal, D. E., R. J. Abitz, D. S. Belski, J. B. Case, M. E. Crawley, R. M. Deshler, P. E. Drez, C. A. Givens, R. B. King, B. A. Lauctes, J. Myers, S. Niou, J. M. Pietz, W. M. Roggenthen, J. R. Tyburski, and M. G. Wallace, 1989, "Brine Sampling and Evaluation Program Report, 1988," *DOE-WIPP 89-015*, prepared for the U.S. Department of Energy by IT Corporation and Westinghouse Electric Corporation, Carlsbad, New Mexico.

Holt, R. M., and D. W. Powers, 1990, "Geologic Mapping of the Air Intake Shaft at the Waste Isolation Pilot Plant," *DOE/WIPP 90-051*, prepared for the U.S. Department of Energy by IT Corporation, Carlsbad, New Mexico.

Sandia National Laboratories/New Mexico (SNL/NM), 1992, "Preliminary Performance Assessment for the Waste Isolation Pilot Plant, December 1992, Volume 3: Model Parameters," *SAND92-0700/3*, WIPP Performance Assessment Division, Sandia National Laboratories, New Mexico.

TSC-D'Appolonia, 1983, "Geologic Mapping of Access Drifts, 'Double Box' Area, Geotechnical Field Data Report No. 5," Carlsbad, New Mexico.

Table C-2-1
Air Intake Shaft Observations of Significant Salt Encrustations

Depth (ft)	Geological Relationships or Observations
998	Minor exposure surface; in SMPH ¹ .
1026-28 P ²	Lower MB 103, in dolomitic anhydrite above claystone.
1030	Slightly argillaceous halite, upper SMPH below MB 103 claystone; mainly from around rock bolts.
1161	Argillaceous nodular anhydrite in lower third of MB 109; from around rock bolts.
1175	Argillaceous halite (DMRH) below halitic claystone (HM) at top of desiccating sequence.
1200	Argillaceous halite (DMRH), at and below contact with overlying SMPH.
1253	Halite with trace clay and polyhalite, underlying thin polyhalite.
1277	Halite, trace clay, from exposure surface at top SMPH, underlying DMRH with halite growth textures.
1302-03	Halite, trace clay, from exposure surface overlying argillaceous halite.
1320	Single weep, near center MB 115, from zone of wavy bedding.
1342-48 PP	Siltstone, Vaca Triste Sandstone Member, from below upper 2 ft of halite-cemented mudstone; many weeps.
1495.5	Base polyhalite (MB 121), above claystone; zone of small salt encrustations.
1510	Argillaceous halite (DMRH), just below contact with overlying SMPH.
1515	Halite (SMPH), just above bedded zone of primary halite ³ and polyhalite laminae.
1549-52	Halite, slightly polyhalitic or slightly argillaceous, lower SMPH; small encrustations.
1613-14	Polyhalite in lower third of MB 123 anhydrite.
1627.5	Anhydrite, top of zone of contorted bedding in lower 1 ft.
1673-75.5 P	Argillaceous halite, at contact with overlying SMPH as well as within unit underlying exposure surface.
1687-88	Argillaceous halite (HM and DMRH), below exposure surface; overlain by SMPH.
1701	Halite, trace of clay, from inches above major exposure surface; maybe at minor bedding plane or exposure surface.
1708	Halite, trace of clay, primary halite and podular texture; from level equivalent to base of pits and pipes.
1710.5	Argillaceous halite, at top of DMRH zone; SMPH overlies exposure surface.
1721	Halite, trace polyhalite; at or from clay at base of polyhalite (MB 126).
1726	Halite (SMPH), at transition from trace of polyhalite to slightly argillaceous halite.
1739.5	Argillaceous halite, podular zone just above exposure surface; underlain by SMPH with primary halite.
1768	Halite, within SMPH, and secondary exposure surface where argillaceous halite overlies polyhalitic halite.

Refer to footnotes at end of table.

Table C-2-1 (Continued)
Air Intake Shaft Observations of Significant Salt Encrustations

Depth (ft)	Geological Relationships or Observations
1770 P	Podular halite, at or across exposure surface of argillaceous halite.
1774 P	Top of podular halite, at same level as base of pits; just above zone of primary halite; encrustations drape about 1 ft of primary halite zone.
1776	At exposure surface, with argillaceous halite overlying polyhalitic and argillaceous halite.
1783	Top of MB 129, polyhalite overlain by SMPH primary halite.
1784.5	Base of MB 129, polyhalite overlying argillaceous halite.
1788	Argillaceous halite overlying secondary exposure surface.
1793	Argillaceous halite under exposure surface overlain by primary SMPH.
1799	Halite, trace polyhalite, at exposure surface overlain by primary halite, slightly argillaceous.
1807.5	Halite, trace clay, at or above exposure surface overlain by podular halite.
1815	Halite, trace of clay, at and below exposure surface in podular halite.
1825 P	Same as 1815.
1833	Halite, trace of clay, at and below exposure surface; overlain by primary halite.
1837	Same as 1833.
1844.5 P	At top and possible from base of thin polyhalite overlain by primary halite.
1847	From within syndimentary dissolution pipe with collapse material.
1862	Top of MB 131, polyhalite overlain by primary halite.
1863 P	Base MB 131, at contact of polyhalite with argillaceous halite.
1867	At exposure surface, with primary halite both above and below.
1873-75	At and below exposure surface in argillaceous halite overlain by primary halite; also within argillaceous halite with displacive halite.
1881	Argillaceous halite, at exposure surface; within bed with polyhalitic halite.
1883	Argillaceous halite, podular halite; within bed with polyhalitic halite.
1887	Halite, with trace of polyhalite, at exposure surface overlain by primary halite with trace of clay.
1895	At exposure surface, probably from clay underlying polyhalite (MB 132).
1914.5	Extensive encrustations mainly associated with rock bolts at claystone under polyhalite (MB 133).
1933	Halite with trace of clay and some polyhalite, under exposure surface overlain by primary halite.
1940 P	Claystone, polyhalitic at base of anhydrite (about 2 ft thick); at major exposure surface.
1947.5	Argillaceous halite at exposure surface, overlain by primary halite.
1959.5 P	Single encrustation in upper third of MB 134 (about 11-ft-thick anhydrite).

Refer to footnotes at end of table.

Table C-2-1 (Continued)
Air Intake Shaft Observations of Significant Salt Encrustations

Depth (ft)	Geological Relationships or Observations
1973	Small encrustations at exposure surface; argillaceous halite above and below surface.
1985 P	Podular argillaceous halite at exposure surface under anhydrite (MB 135).
1989	Minor encrustations in halite at level of base of secondary pits and pipes.
1995.5 P	At exposure surface in argillaceous halite, overlain by halite.
2000, 2001 P	At secondary exposure surface in argillaceous halite overlying halite.
2012.5	At exposure surface, may come from primary halite just above contact.
2016	Argillaceous halite below exposure surface; overlain by primary halite.
2022	Podular halite, at change from polyhalite and polyhalitic halite to increasing clay upward.
2027	Encrustations around rock bolts at polyhalite-anhydrite transition, upper third of MB 136.
2040	At thin anhydrite overlying exposure surface; may also be at contact with overlying primary halite.
2076.5	Claystone at exposure surface, overlain by thin anhydrite.
2079.5 P	Halitic claystone (also called M-1 in reference stratigraphy for rock mechanics calculations) at exposure surface.
2084.5 P	Halitic claystone (L in reference stratigraphy for rock mechanics calculations) at exposure surface.
2090	Argillaceous halite in podular zone at top secondary exposure surface; overlain by primary halite.
2094	At secondary exposure surface where podular argillaceous halite overlies polyhalitic halite.
2099 P	Top of anhydrite (MB 138), overlain by primary halite.
2099.5 P	Argillaceous halite and claystone (K in reference stratigraphy for rock mechanics calculations) at exposure surface at base of MB 138.
2108	Argillaceous halite in podular zone underlying exposure surface.
2110-11 P	At minor exposure surfaces within halite with trace polyhalite.

¹Facies designations (e.g., SMPH) are taken from Holt and Powers (1990) "Geologic Mapping of the Air Intake Shaft at the Waste Isolation Pilot Plant," *DOE/WIPP 90-051*, U.S. Department of Energy, Carlsbad, New Mexico.

²P signifies a photograph is included as a figure in this report.

³"Primary halite" refers to halite with observable textures as evidence of subaqueous growth. All Salado Formation halite is believed to have been deposited during the Permian Age.

THIS PAGE INTENTIONALLY LEFT BLANK

Figure C-2-1

Composite photograph of MB 103 and encrustations in lower part.

*Taken toward south, near 1029 ft depth.
Note gray claystone in lower third of
photograph.*



Figure C-2-2

Photograph of uppermost Vaca Triste SS Mbr (1340 – 1342) with weeps below halite cemented zone.

Taken toward south.



Figure C-2-3

Photograph of extensive weeps in lower Vaca Triste SS Mbr.

Taken south side of shaft.

Figure C-2-4

Photograph of upper
Union Anhydrite Mbr
(about 1530 ft)

*Taken toward south,
note lack of weeps.*



Figure C-2-4

Small encrustations at the
exposure surface over
argillaceous halite.

*Taken south side of shaft,
about 1672 ft.*

Figure C-2-6

Photograph of encrustations at exposure surfaces in argillaceous halite.

*Taken toward south,
about 1765 - 1775 ft.*

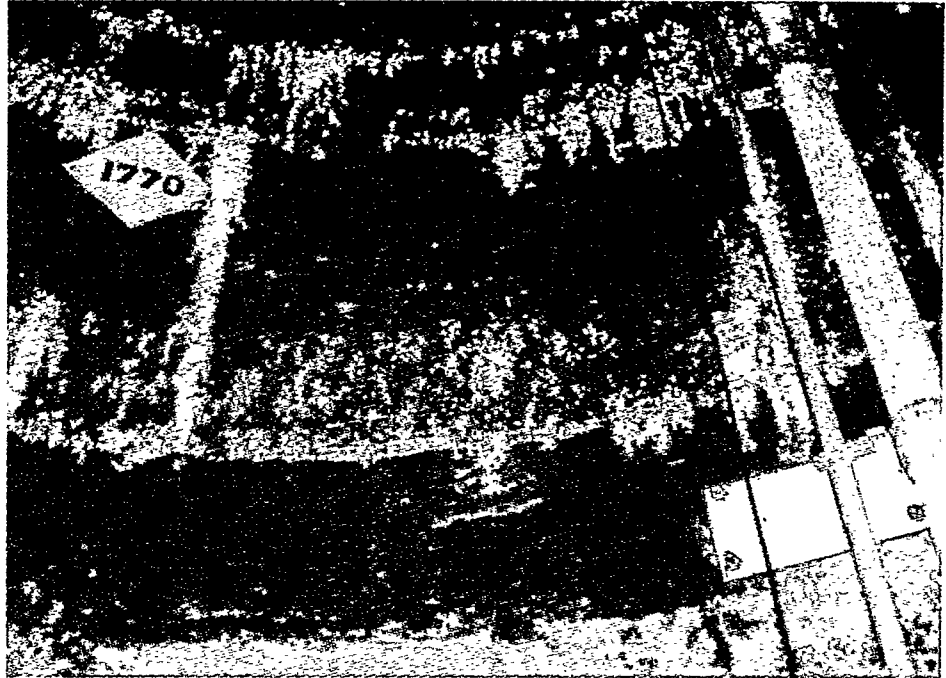
**Figure C-2-7**

Photograph of small encrustations in argillaceous halite at and below exposure surface at 1825 ft.

*Taken south side of shaft, about
1825 ft.*

*Purer halite with primary textures
above exposure surface shows no
encrustations.*

Figure C-2-8

Photograph of encrustations at polyhalite at 1844.5 ft.

Taken toward south, about 1844.5 ft.

Note small encrustations from primary halite with polyhalite from about 1843 – 1844 ft.

**Figure C-2-9**

Encrustations in claystone under MB 131 at 1863 ft. Additional encrustations from argillaceous halite below exposure surface.

Taken south side of shaft, about 1863 ft.

“Podular” halite textures are well shown in lower third of photograph.

Figure C-2-10

Photograph of encrustations at base of anhydrite.

Taken toward south, near 1940 ft.

Note small encrustations from argillaceous halite under exposure surface.

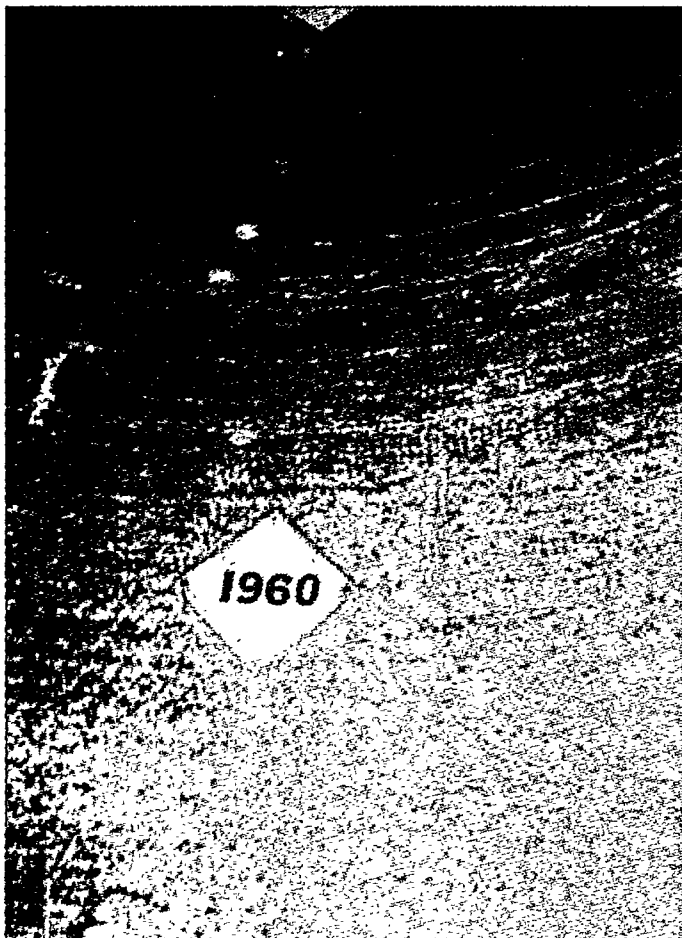

Figure C-2-11

Isolated encrustations in MB 134 at about 1960 ft in upper part of unit.

Taken south side of shaft, about 1960 ft.

Figure C-2-12

Photograph of encrustations at base anhydrite of MB 135

Taken toward south, near 1985 ft depth.

Note small encrustations from gray argillaceous halite in synsedimentary pit or "cave" above MB.

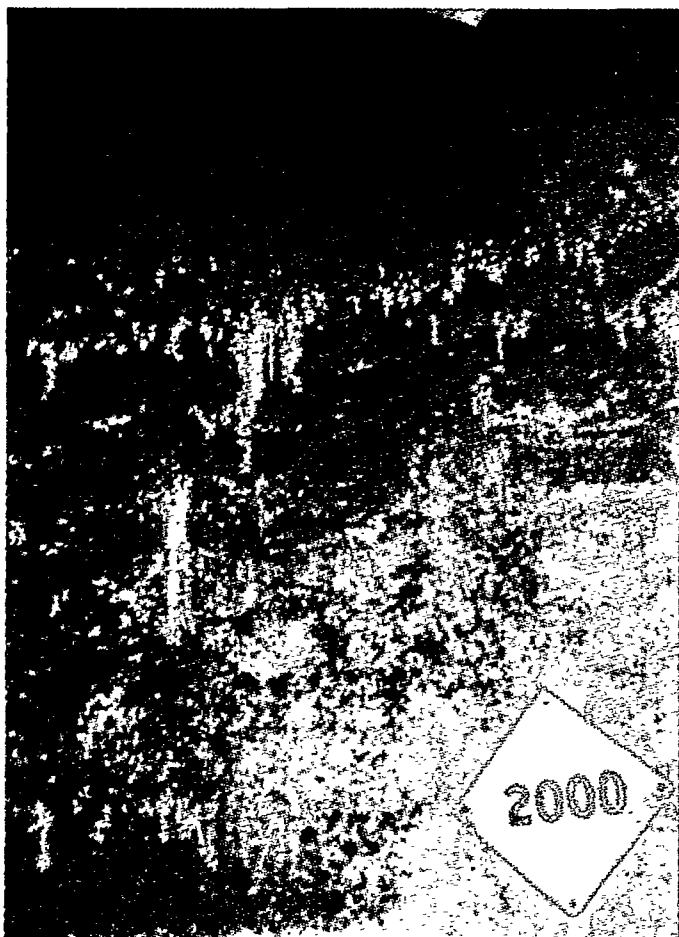
**Figure C-2-13**

Encrustations in argillaceous halite at top of exposure surface overlain by halite at about 1995 ft.

Taken south side of shaft, note dish-shaped structures below exposure surface, isolated encrustations.

Figure C-2-14

Photograph of encrustations at exposure surfaces with claystones M-1 (above sign) and L (below sign).

Taken toward south, about 2080 ft.

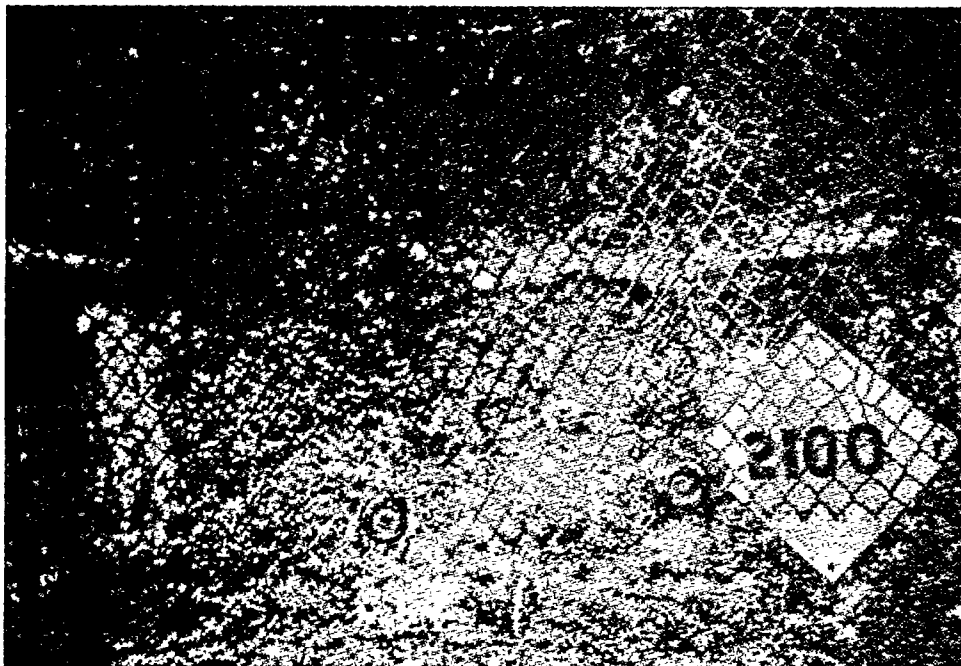
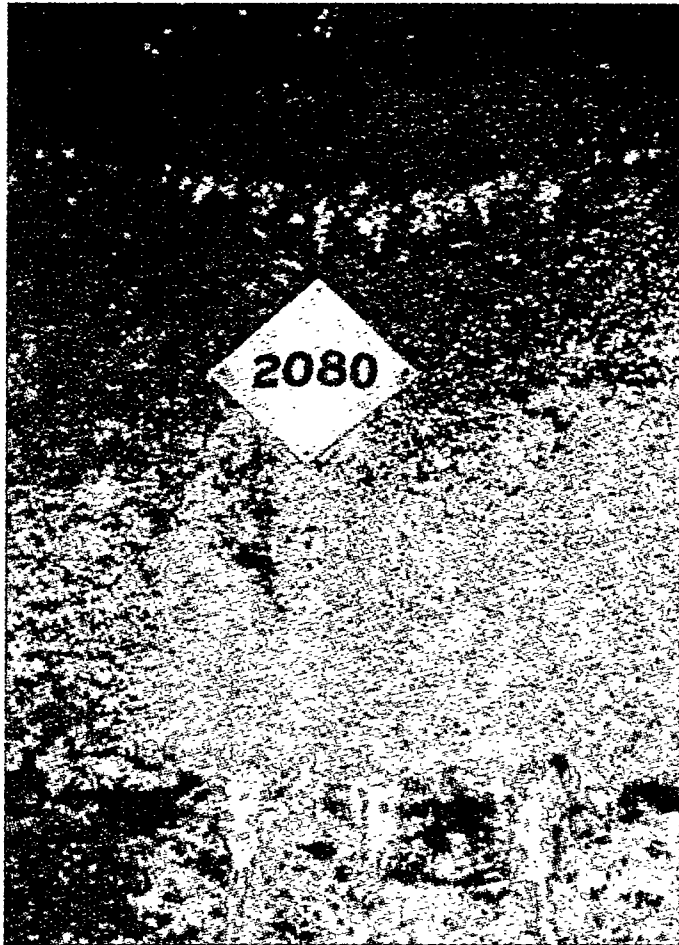
**Figure C-2-15**

Encrustations at claystone K at exposure surface under MB 138.

Taken south side of shaft, about 2100 ft.

Clay-MB contact about middle of photograph.

Figure C-2-16

Small encrustations
at exposure surface
overlying argillaceous
halite and along
polyhalitic laminae in
halite.

*Taken about 2110 ft
depth, south wall.*

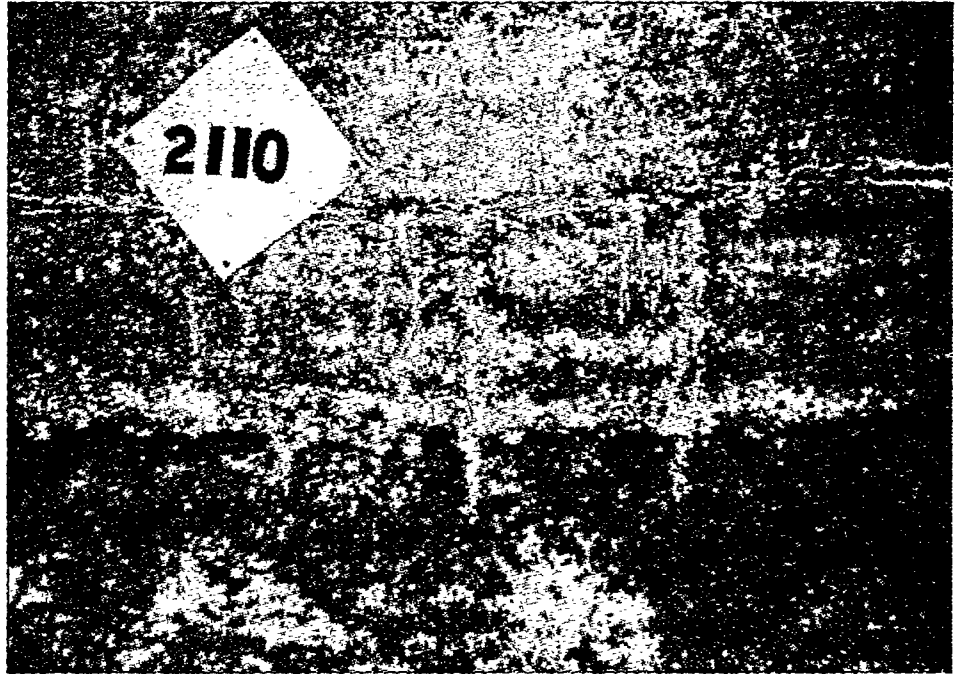

APPENDIX D
ANALYTICAL RESULTS

PART I—1992-1993 ANALYTICAL RESULTS FOR SALADO BRINE

PART II—ANALYTICAL RESULTS FOR CULEBRA AND CONSTRUCTION BRINES

THIS PAGE INTENTIONALLY LEFT BLANK

APPENDIX D
ANALYTICAL RESULTS

PART I—1992-1993 ANALYTICAL RESULTS FOR SALADO BRINE

THIS PAGE INTENTIONALLY LEFT BLANK

**TABLE D-1
ANALYTICAL RESULTS FOR SALADO BRINES**

SAMPLE NUMBER	HOLE NUMBER & DIRECTION	LAB	DATE	pH ^a (s.u.)	SG ^b (g/cm ³)	TDS ^c (mg/L)	EXT ALK ^d (mg/L)	TIC ^e (mg/L)	TOC ^e (mg/L)	Br (mg/L)	Cl (mg/L)	F (mg/L)	I (mg/L)	NO3 (mg/L)	NH4 (mg/L)	P (mg/L)	SO4 (mg/L)	
4037	A1X02	UP	UNC	04/16/92	5.8	1.24	394000	897	< 2.5	15	2310	195000	6.8	15.6	0.3	166	< 0.1	21000
4050	A1X02	UP	UNC	08/20/92	3.5	1.23	415000	NA	< 2.5	41	6330	259000	< 1	40.7	< 1	356	0.2	36600
4038	A3X01	DN	UNC	04/16/92	6.1	1.23	374000	1019	4.1	25	1660	188000	6.7	16.2	0.2	175	< 0.1	16100
4049	A3X01	DN	UNC	08/20/92	6.0	1.23	338000	937	3.0	15	1480	192000	6	13.6	< 1	177	< 0.1	16500
4036	BX01	DN	UNC	04/16/92	6.2	1.23	373000	897	2.5	15	1580	190000	5.8	15.5	< 0.2	148	< 0.1	16000
4052	BX01	DN	UNC	08/20/92	6.0	1.22	344000	876	2.5	5	1460	189000	6	13.3	< 1	175	< 0.1	16600
4024	DH36	DN	UNC	04/16/92	6.2	1.24	375000	848	5.1	36	1560	192000	4.6	24.5	< 0.2	189	< 0.1	16000
4025	DH36	DN	UNC	04/16/92	6.2	1.24	372000	848	5.6	30	1590	193000	4.7	24.2	< 0.2	188	< 0.1	16000
4026	DH36	DN	UNC	04/16/92	6.2	1.24	377000	848	5.1	36	1590	192000	4.8	20.2	< 0.2	164	< 0.1	16000
4048	DH36	DN	UNC	08/20/92	6.2	1.23	348000	821	5.6	15	1450	192000	4	15.6	< 1	186	< 0.1	16500
4034	DH38	DN	UNC	04/16/92	6.3	1.24	372000	958	4.1	61	1540	190000	4.2	21.2	0.2	193	< 0.1	14900
4051	DH38	DN	UNC	08/20/92	6.2	1.22	357000	931	4.1	15	1420	194000	4	15.3	< 1	190	< 0.1	15600
4035	DH40	DN	UNC	04/16/92	6.4	1.22	365000	1140	6.1	71	1580	186000	4.3	21.8	0.5	184	0.1	15200
4055	DH40	DN	UNC	08/20/92	6.4	1.23	345000	1199	5.1	56	1460	188000	5	15.2	< 1	196	< 0.1	15700
4033	DH42	DN	UNC	04/16/92	6.3	1.25	372000	915	3.6	41	1540	187000	4.4	19.7	0.4	195	< 0.1	14800
4053	DH42	DN	UNC	08/20/92	6.2	1.23	344000	906	3.0	46	1410	189000	4	15.0	< 1	197	0.1	15300
4021	DH42A	DN	UNC	04/16/92	6.2	1.24	374000	848	4.1	15	1490	193000	4.4	23.2	< 0.2	191	< 0.1	15100
4022	DH42A	DN	UNC	04/16/92	6.2	1.24	376000	848	4.6	10	1500	192000	4.2	25.8	< 0.2	214	< 0.1	15100
4023	DH42A	DN	UNC	04/16/92	6.2	1.24	373000	842	5.6	15	1510	194000	4.5	25.8	< 0.2	185	< 0.1	15100
4054	DH42A	DN	UNC	08/20/92	6.1	1.23	349000	833	3.0	< 5	1400	190000	4	15.2	< 1	215	< 0.1	15300
4030	DHP402A	DN	UNC	04/16/92	6.1	1.24	378000	763	3.6	10	1690	192000	6.4	14.5	0.3	150	< 0.1	16700
4031	DHP402A	DN	UNC	04/16/92	6.1	1.24	381000	787	3.6	15	1670	193000	6.3	14.3	< 0.2	142	< 0.1	16600
4032	DHP402A	DN	UNC	04/16/92	6.1	1.25	380000	787	2.5	10	1690	192000	6.2	14.5	0.2	138	< 0.1	16600
4047	DHP402A	DN	UNC	08/20/92	6.0	1.23	339000	730	7.1	15	1540	192000	7	12.0	< 1	175	< 0.1	17400
4027	GSEEP	DN	UNC	04/16/92	6.3	1.24	374000	946	3.0	< 5	1520	186000	3.2	21.9	< 0.2	205	< 0.1	26700
4028	GSEEP	DN	UNC	04/16/92	6.3	1.24	373000	958	2.5	< 5	1520	186000	3.0	20.7	0.3	197	< 0.1	26700

^a s.u. = standard units

^b Specific Gravity

^c Total Dissolved Solids

^d Extended Alkalinity measured to an endpoint pH of 2.5 and reported as equivalent bicarbonate (HCO₃).

^e TIC (Total Inorganic Carbon) and TOC (Total Organic Carbon) are reported as equivalent bicarbonate.

NA Not available.

DN Down

HZ Horizontal

**TABLE D-1
ANALYTICAL RESULTS FOR SALADO BRINES**

SAMPLE NUMBER	HOLE NUMBER & DIRECTION	LAB	DATE	Al	As	B	Ba	Ca	Cs	Fe	K	Mg	Mn	Na	Rb	Si	Sr	CHARGE BALANCE (percent)	
				(mg/L)	(mg/L)	(mg/L)	(mg/L)	(mg/L)	(mg/L)	(mg/L)	(mg/L)	(mg/L)	(mg/L)	(mg/L)	(mg/L)	(mg/L)	(mg/L)		(mg/L)
4037	A1X02	UP	UNC	04/16/92	< 0.05	0.01	1700	0.053	252	0.379	< 0.50	15700	35000	4.69	63000	18.5	1.29	5.77	NA
4050	A1X02	UP	UNC	08/20/92	0.3	0.02	4590	0.026	27	0.566	0.56	13800	86000	5.27	8300	14.9	3.37	< 0.1	NA
4038	A3X01	DN	UNC	04/16/92	< 0.05	< 0.001	1590	0.081	249	0.368	< 0.50	16200	24000	1.51	78000	16.2	1.60	1.75	NA
4049	A3X01	DN	UNC	08/20/92	< 0.05	0.002	1600	0.061	245	0.368	< 0.50	16100	23200	1.45	78000	15.5	1.07	1.76	NA
4036	BX01	DN	UNC	04/16/92	< 0.05	0.001	1560	0.074	256	0.336	< 0.50	16200	22700	1.25	80000	15.2	1.22	1.80	NA
4052	BX01	DN	UNC	08/20/92	0.06	0.002	1570	0.067	241	0.356	< 0.50	16100	22200	1.31	78000	15.3	0.76	1.79	NA
4024	DH36	DN	UNC	04/16/92	< 0.05	0.003	1680	0.14	296	0.285	< 0.50	18300	18400	1.12	83000	14.6	1.91	1.22	NA
4025	DH36	DN	UNC	04/16/92	< 0.05	0.003	1670	0.123	301	0.29	< 0.50	18800	18900	1.12	84000	14.3	1.83	1.28	NA
4026	DH36	DN	UNC	04/16/92	< 0.05	0.003	1660	0.064	294	0.281	< 0.50	18200	19300	1.09	85000	14.2	1.88	1.20	NA
4048	DH36	DN	UNC	08/20/92	0.06	0.009	1650	0.095	286	0.295	1.67	17700	18700	1.09	86000	14.1	1.70	1.21	NA
4034	DH38	DN	UNC	04/16/92	< 0.05	< 0.001	1610	0.039	305	0.267	< 0.50	18000	18300	0.94	86000	14.0	2.45	0.77	NA
4051	DH38	DN	UNC	08/20/92	< 0.05	< 0.001	1630	0.06	277	0.283	< 0.50	17700	18300	0.97	85000	13.9	1.48	0.74	NA
4035	DH40	DN	UNC	04/16/92	< 0.05	0.002	1600	0.087	302	0.259	< 0.50	18900	18200	1.72	84000	13.8	2.34	0.96	NA
4055	DH40	DN	UNC	08/20/92	< 0.05	0.001	1640	0.056	270	0.270	< 0.50	18200	18300	3.14	84000	14.0	1.69	0.84	NA
4033	DH42	DN	UNC	04/16/92	< 0.05	0.004	1600	0.055	302	0.256	< 0.50	18300	17800	1.07	85000	13.5	1.82	0.84	NA
4053	DH42	DN	UNC	08/20/92	0.08	0.006	1630	0.056	294	0.259	< 0.50	18100	17500	1.12	86000	13.5	1.42	0.80	NA
4021	DH42A	DN	UNC	04/16/92	< 0.05	0.004	1620	0.058	294	0.253	< 0.50	18700	17700	1.00	88000	13.7	2.21	0.75	NA
4022	DH42A	DN	UNC	04/16/92	< 0.05	0.004	1630	0.046	291	0.253	< 0.50	19100	17900	0.96	88000	13.2	2.21	0.75	NA
4023	DH42A	DN	UNC	04/16/92	< 0.05	0.004	1620	0.057	296	0.253	< 0.50	19100	17800	0.97	87000	13.7	2.12	0.75	NA
4054	DH42A	DN	UNC	08/20/92	0.06	0.004	1540	0.056	273	0.251	< 0.50	17000	17000	0.98	84000	12.9	1.57	0.75	NA
4030	DHP402A	DN	UNC	04/16/92	< 0.05	< 0.001	1370	0.065	294	0.368	67.5	14900	24600	2.56	75000	15.5	0.50	2.70	NA
4031	DHP402A	DN	UNC	04/16/92	< 0.05	< 0.001	1380	0.056	280	0.363	21.4	15000	25400	2.18	77000	15.8	< 0.5	2.44	NA
4032	DHP402A	DN	UNC	04/16/92	< 0.05	< 0.001	1390	0.08	283	0.352	14.0	15000	25200	2.10	77000	15.3	< 0.5	2.49	NA
4047	DHP402A	DN	UNC	08/20/92	< 0.05	0.002	1540	0.155	270	0.371	> 99	14800	26900	3.10	79000	15.1	< 0.5	2.47	NA
4027	GSEEP	DN	UNC	04/16/92	< 0.05	0.006	1720	0.061	249	0.215	< 0.50	14300	15100	0.64	96000	12.2	1.25	1.96	NA
4028	GSEEP	DN	UNC	04/16/92	< 0.05	0.007	1750	0.074	260	0.217	< 0.50	14500	15000	0.64	94000	12.2	1.22	2.24	NA
4029	GSEEP	DN	UNC	04/16/92	< 0.05	0.006	1710	0.031	251	0.223	< 0.50	14800	15200	0.63	95000	12.3	1.35	1.96	NA

NA Not available.

**TABLE D-1
ANALYTICAL RESULTS FOR SALADO BRINES**

SAMPLE NUMBER	HOLE NUMBER & DIRECTION	LAB	DATE	pH ^a (s.u.)	SG ^b (g/cm ³)	TDS ^c (mg/L)	EXT ALK ^d (mg/L)	TIC ^e (mg/L)	TOC ^e (mg/L)	Br (mg/L)	Cl (mg/L)	F (mg/L)	I (mg/L)	NO3 (mg/L)	NH4 (mg/L)	P (mg/L)	SO4 (mg/L)	
4029	GSEEP	DN	UNC	04/16/92	6.3	1.24	373000	946	3.0	5	1520	185000	3.3	19.8	0.2	178	< 0.1	26500
4046	GSEEP	DN	UNC	08/20/92	6.3	1.24	359000	943	< 2.5	< 5	1410	184000	4	17.0	< 1	199	< 0.1	26900
4039	OH20	HZ	UNC	04/16/92	6.0	1.23	385000	656	3.6	56	1500	193000	4.8	15.1	1.2	131	< 0.1	17100
4058	OH20	HZ	UNC	08/20/92	5.9	1.22	354000	675	3.0	56	1480	188000	4	13.3	< 1	175	< 0.1	16500
4044	OH22	HZ	UNC	04/16/92	6.3	1.23	371000	946	5.1	81	1570	188000	4.1	15.7	0.3	150	0.2	15400
4040	OH23	HZ	UNC	04/16/92	6.0	1.22	371000	614	3.0	41	1530	190000	5.2	15.2	1.1	135	< 0.1	16400
4056	OH23	HZ	UNC	08/20/92	5.9	1.22	335000	597	< 2.5	36	1460	185000	4	13.0	< 1	170	< 0.1	15800
4045	OH24	HZ	UNC	04/16/92	6.3	1.23	376000	909	4.6	86	1610	190000	4.7	16.3	0.5	175	0.4	16000
4041	OH26	HZ	UNC	04/16/92	6.1	1.23	379000	681	2.5	66	1530	189000	4.8	15.2	0.9	136	0.1	16100
4057	OH26	HZ	UNC	08/20/92	6.0	1.22	340000	687	< 2.5	61	1480	186000	4	13.5	< 1	180	0.1	15800
4059	OH28	DN	UNC	08/20/92	6.0	1.22	335000	760	10.2	97	1470	188000	5	14.3	< 1	168	0.7	16300
4042	OH45	HZ	UNC	04/16/92	6.3	1.23	372000	946	6.6	91	1650	188000	4.8	15.8	0.6	150	< 0.1	16000
4043	OH46	DN	UNC	04/16/92	6.3	1.23	364000	946	6.1	36	1640	188000	4.7	15.8	< 0.2	149	< 0.1	15000
4060	OH46	DN	UNC	08/20/92	6.1	1.22	339000	1016	4.6	30	1600	188000	5	14.4	< 1	182	< 0.1	16000

^a s.u. = standard units

^b Specific Gravity

^c Total Dissolved Solids

^d Extended Alkalinity measured to an endpoint pH of 2.5 and reported as equivalent bicarbonate (HCO₃).

^e TIC (Total Inorganic Carbon) and TOC (Total Organic Carbon) are reported as equivalent bicarbonate.

NA Not available.

DN Down

HZ Horizontal

**TABLE D-1
ANALYTICAL RESULTS FOR SALADO BRINES**

SAMPLE NUMBER	HOLE NUMBER & DIRECTION	LAB	DATE	Al	As	B	Ba	Ca	Cs	Fe	K	Mg	Mn	Na	Rb	Si	Sr	CHARGE BALANCE (percent)	
				(mg/L)	(mg/L)	(mg/L)	(mg/L)	(mg/L)	(mg/L)	(mg/L)	(mg/L)	(mg/L)	(mg/L)	(mg/L)	(mg/L)	(mg/L)	(mg/L)		(mg/L)
4046	GSEEP	DN	UNC	08/20/92	< 0.05	0.006	1800	0.045	245	0.235	< 0.50	14500	15700	0.71	97000	12.3	0.93	2.01	NA
4039	OH20	HZ	UNC	04/16/92	< 0.05	0.002	1480	0.03	336	0.281	< 0.50	15600	21600	1.87	82000	15.1	1.43	1.54	NA
4058	OH20	HZ	UNC	08/20/92	0.07	0.002	1420	0.095	267	0.281	< 0.50	14800	21400	2.11	78000	14.3	1.88	0.98	NA
4044	OH22	HZ	UNC	04/16/92	< 0.05	0.002	1510	0.1	291	0.298	1.16	16200	21400	1.58	78000	15.3	2.96	0.95	NA
4040	OH23	HZ	UNC	04/16/92	0.06	0.002	1470	0.045	279	0.285	< 0.50	15400	21900	1.73	80000	15.3	1.54	0.89	NA
4056	OH23	HZ	UNC	08/20/92	0.13	0.002	1490	0.06	270	0.288	< 0.50	15400	21300	1.70	80000	14.8	0.94	0.87	NA
4045	OH24	HZ	UNC	04/16/92	< 0.05	0.003	1510	0.062	294	0.291	< 0.50	15900	22300	1.85	80000	15.0	2.96	0.97	NA
4041	OH26	HZ	UNC	04/16/92	< 0.05	< 0.001	1460	0.061	276	0.290	< 0.50	15500	22200	1.70	80000	14.9	1.32	0.83	NA
4057	OH26	HZ	UNC	08/20/92	0.18	0.001	1470	0.051	261	0.294	< 0.50	15000	21600	1.67	79000	14.8	0.75	0.79	NA
4059	OH28	DN	UNC	08/20/92	0.12	0.002	1520	0.061	314	0.291	1.22	15700	21500	1.79	80000	14.8	1.01	1.36	NA
4042	OH45	HZ	UNC	04/16/92	0.2	0.002	1460	0.116	286	0.272	< 0.50	16400	21000	1.54	77000	15.0	1.40	2.12	NA
4043	OH46	DN	UNC	04/16/92	< 0.05	< 0.001	1520	0.037	277	0.286	< 0.50	16100	20800	1.31	79000	14.9	1.09	1.69	NA
4060	OH46	DN	UNC	08/20/92	0.09	0.001	1590	0.088	264	0.308	< 0.50	20000	21500	1.47	79000	15.3	0.73	0.98	NA

NA Not available.

APPENDIX D
ANALYTICAL RESULTS

PART II— ANALYTICAL RESULTS FOR CULEBRA AND CONSTRUCTION BRINES

THIS PAGE INTENTIONALLY LEFT BLANK

**TABLE D-2
ANALYTICAL RESULTS FOR CULEBRA AND CONSTRUCTION BRINES**

SAMPLE NUMBER	HOLE NUMBER & DIRECTION	LAB	DATE	pH ^a (s.u.)	SG ^b (g/cm ³)	TDS ^c (mg/L)	EXT ALK ^d (mg/L)	TIC ^e (mg/L)	TOC ^e (mg/L)	Br (mg/L)	Cl (mg/L)	F (mg/L)	I (mg/L)	NO3 (mg/L)	NH4 (mg/L)	P (mg/L)	SO4 (mg/L)
1062	AIS CLBRA	UNC	03/03/90	8.1	1.04	48000	113	72.6	10	28	20600	0.7	0.2	0.1	0.34	< 0.1	8230
0482	AIS SUMP	UNC	07/29/88	7.1	1.21	330000	122	94.0	10	37	190000	4	< 0.1	5	4.3	< 1	6150
0484	AIS SUMP	UNC	07/29/88	7.1	1.21	333000	116	94.5	5	44	188000	< 1	< 0.1	6	4.0	< 1	6180
0486	AIS SUMP	UNC	07/29/88	7.1	1.21	333000	128	91.9	30	44	187000	< 1	< 0.1	6	4.5	< 1	6170
0747	AIS SUMP	UNC	04/06/89	8.2	1.06	96000	122	77.7	20	35	50700	1.4	0.2	< 1	0.33	< 0.1	7750
0748	AIS SUMP	UNC	04/26/89	7.4	1.20	331000	177	112.8	91	90	187000	< 1	0.2	10	3.23	< 0.1	10700
0738	B&E BRINE	UNC	03/14/89	6.6	1.21	324000	201	201	5	26	187000	6	1.6	5	0.39	< 0.3	3610
0740	B&E BRINE	UNC	03/14/89	6.5	1.22	324000	188	191	51	19	187000	2	1.4	4	0.26	< 0.3	3590
0742	B&E BRINE	UNC	03/14/89	6.8	1.22	324000	183	179	36	23	187000	< 1	1.4	4	0.28	< 0.3	3590

SAMPLE NUMBER	HOLE NUMBER & DIRECTION	LAB	DATE	Al (mg/L)	As (mg/L)	B (mg/L)	Ba (mg/L)	Ca (mg/L)	Cs (mg/L)	Fe (mg/L)	K (mg/L)	Mg (mg/L)	Mn (mg/L)	Na (mg/L)	Rb (mg/L)	Si (mg/L)	Sr (mg/L)	CHARGE BALANCE (percent)
1062	AIS CLBRA	UNC	03/03/90	< 0.05	< 0.001	35	0.027	822	NA	0.51	376	568	< 0.5	15800	NA	3.84	10.72	1.95
0482	AIS SUMP	UNC	07/29/88	0.167	0.002	13	0.236	950	0 NA	0.13	1720	1040	0.39	118000	NA	3.32	30.7	-1.67
0484	AIS SUMP	UNC	07/29/88	0.163	0.002	12	0.239	950	NA	0.12	1720	1040	0.39	118000	NA	3.33	30.5	-1.16
0486	AIS SUMP	UNC	07/29/88	0.169	0.002	13	0.215	960	NA	0.12	1720	1040	0.4	118000	NA	3.26	30.5	-0.89
0747	AIS SUMP	UNC	04/06/89	1.35	0.002	30	0.069	989	< 0.01	0.98	496	629	0.18	32600	NA	8.19	13.9	-1.99
0748	AIS SUMP	UNC	04/26/89	2.41	0.002	31	0.196	669	0.021	1.42	3210	1630	< 0.1	121000	NA	8.56	33.4	0.10
0738	B&E BRINE	UNC	03/14/89	< 0.05	0.004	2	0.106	1550	0.054	< 0.5	11	43	< 0.1	120000	NA	49.3	23.8	-0.50
0740	B&E BRINE	UNC	03/14/89	< 0.05	0.003	2	0.104	1500	0.01	< 0.5	11	44	< 0.1	119000	NA	50.3	23.6	-0.92
0742	B&E BRINE	UNC	03/14/89	< 0.05	0.003	1	0.112	1520	0.005	< 0.5	11	42	< 0.1	121000	NA	49.9	23.9	-0.09

^a s.u. = standard units

^b Specific Gravity

^c Total Dissolved Solids

^d Extended Alkalinity measured to an endpoint pH of 2.5 and reported as equivalent bicarbonate (HCO₃).

^e TIC and TOC are reported as equivalent bicarbonate.

NA Not available.

THIS PAGE INTENTIONALLY LEFT BLANK

APPENDIX E
HYDROLOGIC TESTING OF THE FRACTURED PART
OF THE DISTURBED ROCK ZONE
BENEATH THE WIPP EXCAVATIONS

THIS PAGE INTENTIONALLY LEFT BLANK

Table of Contents

E1.0	Introduction	E-1
E2.0	Description of the Test Areas	E-2
E2.1	Test Site Locations	E-2
E2.1.1	S90 Near the AIS Test Site	E-4
E2.1.2	E0 at N620 Test Site	E-4
E2.1.3	W170 at the Underground Core Storage Library Test Site	E-8
E2.2	Test Hole Configurations	E-8
E3.0	Preparatory Activities	E-10
E3.1	Drilling of Test Boreholes	E-10
E3.2	Equipment Installation	E-10
E3.3	Geologic and Drilling Logs	E-12
E3.4	Scratcher Rod Survey	E-12
E3.5	Hole Depths	E-12
E4.0	Observations and Test Site Conditions	E-14
E4.1	E0 Test Site Prior to the Initial Pumping Test	E-15
E4.2	W170/Core Library Test Site	E-19
E4.3	E0 Test Site Prior to the Retest at This Site	E-23
E5.0	Hydrologic Testing and Data Collection	E-24
E5.1	Initial Pumping Drawdown Test at the E0 Drift Site	E-29
E5.1.1	Test Performance and Results	E-32
E5.1.2	Pumping Test Analysis	E-34
E5.2	Initial Pump Test at the Core Storage Library (W170) Site	E-41
E5.3.1	Test Performance and Results	E-50
E5.4	Geologic Logging of Cores	E-53
E6.0	Summary and Recommendations	E-55
E7.0	References	E-58

THIS PAGE INTENTIONALLY LEFT BLANK

APPENDIX E

E1.0 Introduction

The main objective of the hydrologic testing of the fractured part of the disturbed rock zone (DRZ) beneath the Waste Isolation Pilot Plant (WIPP) Excavations Program is to characterize the fracture system beneath the floor of the repository. The data resulting from this program will be used by Waste Isolation Division personnel to develop operational plans for predicting brine and gas movement through the fracture system. Additionally, the data obtained may be useful in refining the design of seals to be used within the repository and in assessing the long-term behavior of flow through the fractured zone.

As salt creeps into the WIPP underground excavations, macrofractures develop in the DRZ beneath the excavations (Bechtel, 1986; see also review by Deal and Roggenthen, 1991). The fractures tend to concentrate in but are not limited to Marker Bed (MB) 139, which is about 3 feet (ft) (1 meter [m]) thick and lies 3 to 6 ft (1 to 2 m) below the floor of most of the WIPP excavations. The developing fracture systems may provide pathways for rapid movement of brine and gas (Deal and Case 1987; Deal and others, 1989; Deal and others, 1991) and are considered to be one of the most likely pathways for migration of constituents of concern (COC) away from the waste storage panels. The hydrologic characteristics of the fractured zone must be understood to predict and, if necessary, modify the movement of fluids and COCs within MB 139 if a release occurred during operation of the facility.

In 1989, a hydraulic test of short duration was conducted in the DRZ beneath the floor of the intersection of the S90 and W620 drifts (Deal and others, 1991). The results indicated that drawdown-type pump testing in the underlying fracture system could be performed successfully and could yield useful hydrologic data about the DRZ. After evaluating the results from the preliminary testing effort, a more comprehensive field testing program was developed, and hydraulic testing was implemented at two additional underground test sites.

This report presents the results of short-duration hydraulic tests conducted at the two additional sites and provides recommendations for further field data collection.

E2.0 Description of the Test Areas

The Salado Formation is predominantly halite, consisting of alternating sequences of halite, argillaceous halite, polyhalitic halite, clay partings 0.40- to 1.2-inches (in.)- (1- to 3-centimeters [cm]-) thick clay layers, and thin anhydrite beds as numerous horizontal discontinuities. Anhydrite beds ranging from a few millimeters to about 3.3 ft (1 m) in thickness are brittle at repository depths. As the salt deforms, the contrast in ductility between the salt and the anhydrite causes preferential fracturing in the brittle anhydrite. MB 139, approximately 3.3 ft (1 m) thick, is located 6.6 ft (2 m) beneath the floor of the excavations and shows how local variation in stratigraphy influences macrofracture development. The dish-shaped fractures that normally develop beneath the floor of excavated rooms are distorted and tend to flatten near the room center (Figure E-2-1). Although the fractures concentrate within the anhydrite, especially beneath the center of drifts or rooms, they also cut the halite and other units (Bechtel, 1986). Air-filled fractures up to 5.9 in. (15 cm) wide have developed two to five years after excavation (Bechtel, 1986). Five years after excavation, the largest observed separation is about 9 in. (23 cm) wide.

Some subhorizontal fracturing has been noted just above clay E, at the base of MB 139, approximately 6.6 ft (2 m) below the floor of the excavations, but no separations at clay E were noted (Bechtel, 1986). This may be the result of creeping salt that deformed upward and pushed against the anhydrite to keep the clay confined.

Near the edges of rooms and drifts, fracturing tends to concentrate in the walls or salt above MB 139 (Figure E-2-1). Eventually fracturing will extend into the salt below MB 139. The zone of macrofractures was expected to extend about 6.6 ft (2 m) below the floor of the excavation at this location and to extend laterally a lesser distance into the bedrock beyond the edges of the rooms. In map view, the fractured zone under investigation is expected to follow the plan of the underground excavations closely.

E2.1 Test Site Locations

The hydrologic testing areas were selected to evaluate various room and drift dimensions, excavation ages, areas where water was introduced for construction purposes, and areas isolated from construction fluids. Three sites were selected for drilling and testing as part of this program.

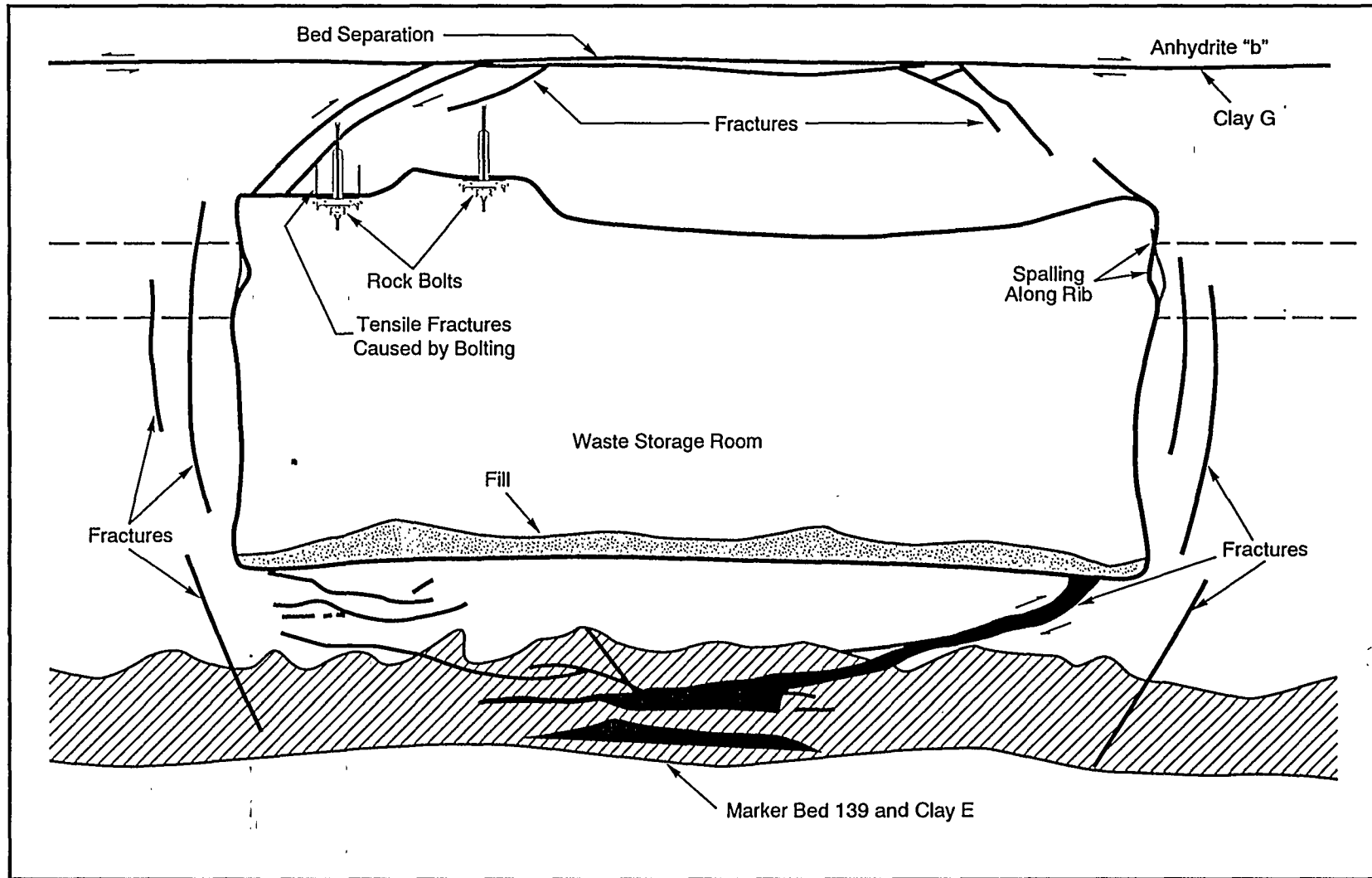

E-3

Figure E-2-1
Idealized Cross Section of Fracturing Around a 4 m-High, 10 m-Wide Waste Storage Room at the WIPP

- Test Site No. 1 is at the intersection of the S90 and W620 drifts near the Air Intake Shaft (AIS). This site consists of 10 test holes drilled at the intersection and along the length of the S90 drift (Figure E-2-2). This test site was not accessible during the field investigation period and is shown as the first hydrologic test site on the map in Figure E-2-2.
- Test Site No. 2 is located in the E0 drift in the general area of N620. The site includes nine test holes drilled along the E0 drift (Figure E-2-2).
- Test Site No. 3 is located in the W170 drift immediately in front of the underground core storage room. This site consists of 11 test holes drilled along the W170 drift and into the core library (Figure E-2-2).

E2.1.1 S90 Near the AIS Test Site

Test Site No. 1 in the S90 drift near the AIS was scheduled to be the third and final location tested for this program. However, hydrologic testing at this site was impossible because of the presence of an electrical substation located in the center of the intersection and electrical transformers located in an adjacent alcove. The position of the electrical equipment covered several of the test holes at this site, making testing impossible. The scope of the field program was revised when it was determined that the electrical equipment could not be moved within the time frame required to meet field-testing program objectives. The final field test was moved from the S90 site to the initial site in the E0 drift to retest this location. Therefore, the S90 test site will not be discussed in detail. Table E-2-1 lists the test hole number, the location, and the date drilling was completed for the test holes drilled as part of this field program.

E2.1.2 E0 at N620 Test Site

This hydrologic test site is located in the E0 drift, directly in front of the N620 alcove. The site was selected because the E0 drift is a very old, wide drift where open brine-filled fractures have been observed beneath the drift floor. Fracturing beneath the drifts develop over time, and they develop fastest beneath the widest drifts.

This site also was easily accessed and offered an existing electrical supply and an area within the N620 alcove to set up instrumentation and store equipment. Figure E-2-3 shows the layout of the E0 test site.

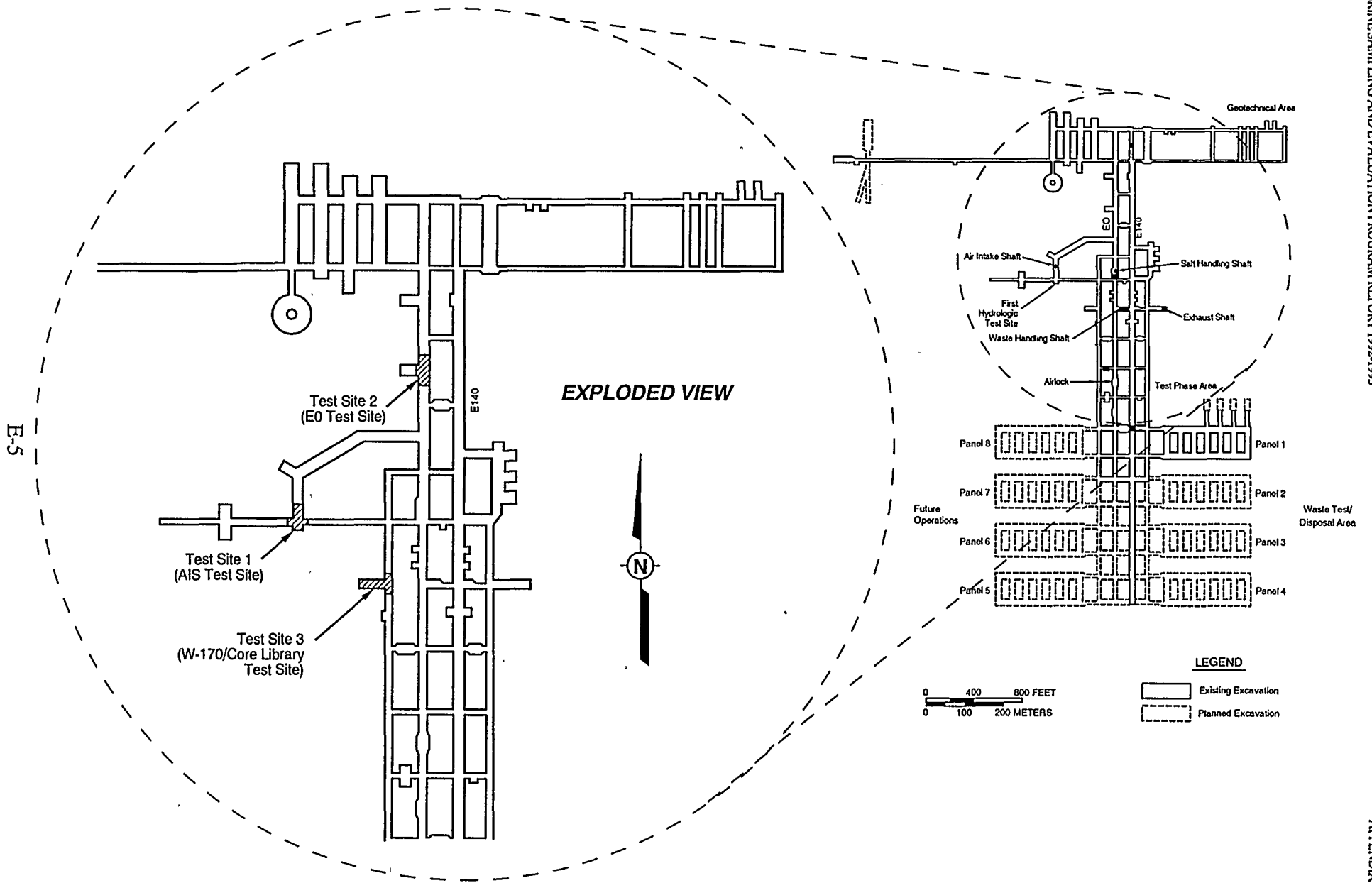

Figure E-2-2
Map of Underground Test Locations

Table E-2-1
Test Holes Drilled as Part of the
Hydrologic Testing of the Fractured Zone

Hole Number	Date Drilled	Hole Location
OH49	1-5-90	W620/S90
OH50	1-9-90	W620/S90
OH51	1-5-90	W620/S90
OH52	1-9-90	W620/S90
OH53	1-11-90	W620/S90
OH54	1-11-90	W620/S90
OH55	1-11-90	W620/S90
OH56	1-16-90	W620/S90
OH57	1-10-90	W620/S90
OH58	1-16-90	W620/S90
OH59	10-19-92	W170/Core Library
OH60	10-19-92	W170/Core Library
OH61	10/19/92	W170/Core Library
OH62	1-24-90	W170/Core Library
OH63	1-19-90	W170/Core Library
OH64	1-23-90	W170/Core Library
OH65	1-23-90	W170/Core Library
OH66	1-18-90	W170/Core Library
OH67	1-22-90	W170/Core Library
OH68	1-19-90	W170/Core Library
OH69	1-17-90	W170/Core Library
OH70	1-29-90	E0/N620
OH71	1-31-90	E0/N620
OH72	1-31-90	E0/N620
OH73	1-31-90	E0/N620
OH74	1-29-90	E0/N620
OH75	1-29-90	E0/N620
OH76	1-31-90	E0/N620
OH77	1-31-90	E0/N620
OH78	1-29-90	E0/N620

301661.009.00.000/rid A12
4/13/95

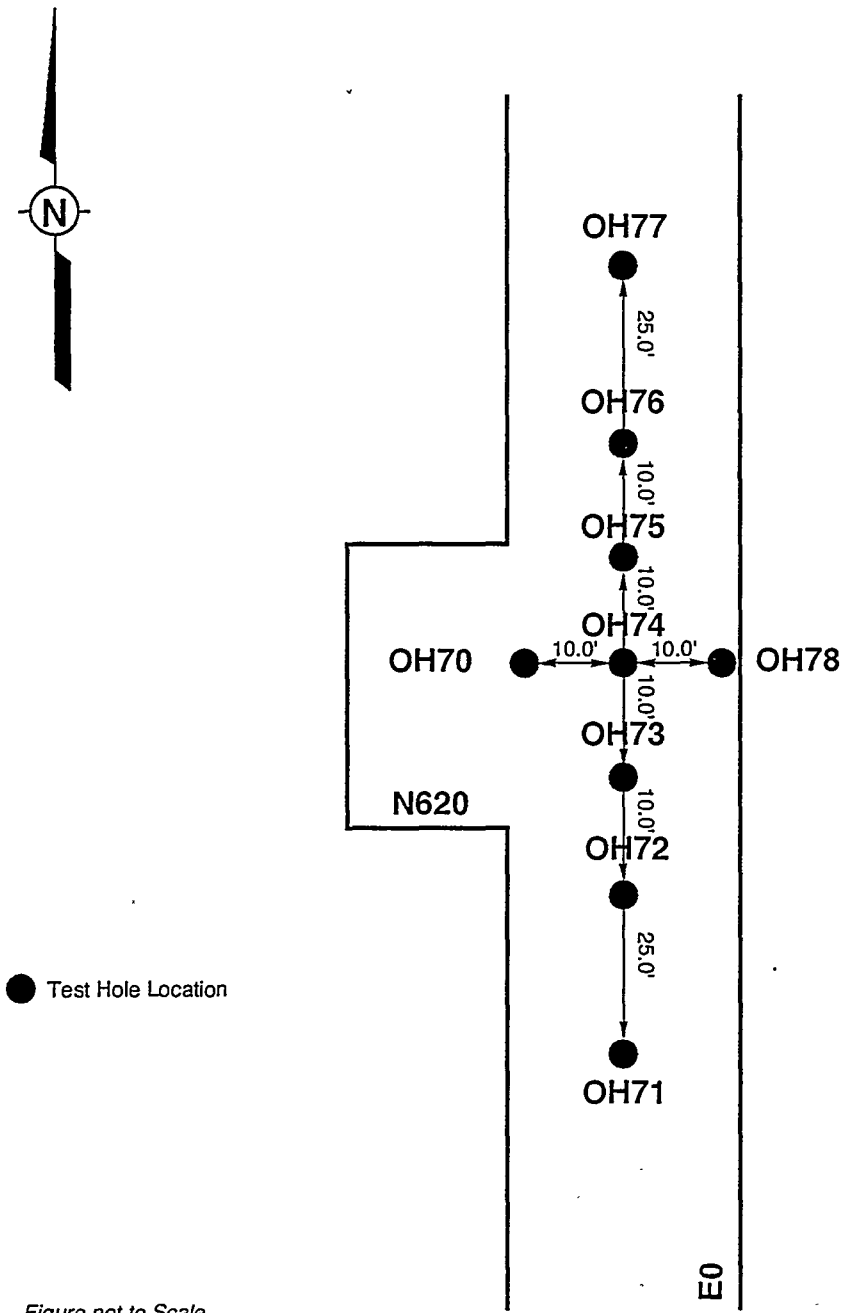

Figure not to Scale

Figure E-2-3
Layout of Test Site No. 2
the E0 Drift in Front of N620,
Holes OH70 through OH78

E2.1.3 W170 at the Underground Core Storage Library Test Site

The third test location is in the W170 drift in front of the underground core library. To best determine the development of the fracture-related transmissivity with time, this site was selected to initiate an investigation of a wide, new drift in the floor before significant fracturing develops. The underground core storage area is a 25-ft-wide, relatively new excavation mined in May 1989 and is in a low-traffic area. The W170 drift adjacent to the core library is approximately five years older than the storage room and was expected to exhibit a well-developed fracture system beneath it. In addition, the W170 drift has been exposed to a long period of water spreading to control dust and to assist in roadbed consolidation. The objectives for this site are to test the fracture systems in the W170 drift and to monitor the development of fracturing beneath the core storage area. A series of boreholes were drilled in the core storage area to evaluate the potential hydraulic connection of the fracture systems within W170 and the core library. A future objective will be to monitor the development of fractured-zone hydraulic characteristics beneath the core library area by periodic retesting.

The site also offered electrical power, equipment storage areas, and convenient and safe access to the test holes. Figure E-2-4 shows the configuration of the W170 test site.

E2.2 Test Hole Configurations

The test locations represent areas with fracture zones that appear to be locally saturated with brine and exhibit some degree of interconnected fracturing. Test holes were installed at each site in a pattern designed to intercept separate fracture systems. At each site, holes were drilled along the length of the drift, as well as perpendicularly to the drift center line. Test holes were also emplaced as close to the drift wall (rib) as possible at both test sites (Figure E-2-3 and E-2-4). Placement of holes in this manner allowed the drawdown response produced by pumping one hole to be observed in multiple directions, potentially identifying individual fracture systems.

301681.009 00.000/ld A13
1/27/95

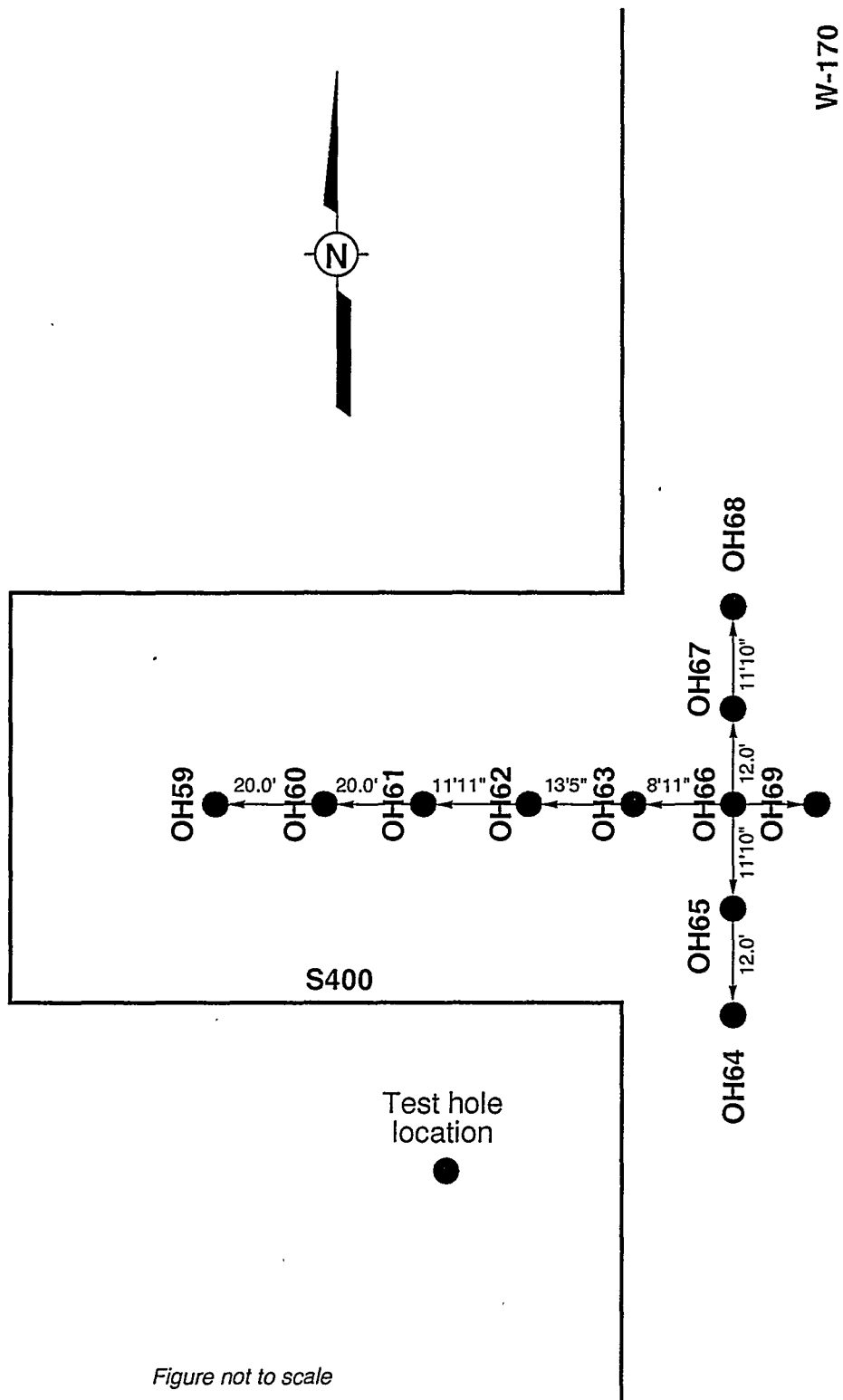

Figure E-2-4
Layout of Test Site No. 3 at the Intersection of S400 and W170 Drifts
(Underground Core Library)
Holes OH59 through OH69

E3.0 Preparatory Activities

The following preparatory activities were performed prior to the pumping drawdown tests:

- Drilling boreholes
- Blowing out boreholes to clear out muck
- Installing equipment
- Surveying hole locations
- Core logging
- Driller logging
- Scratcher rod surveying
- Measuring fluid levels
- Measuring hole depths
- Observing the condition of the holes.

E3.1 Drilling of Test Boreholes

Boreholes were drilled at three separate test sites in the WIPP underground workings (Figure E-2-2). All holes were cored vertically downward to a depth of approximately 1 ft (0.30 m) beneath the base of MB 139 and are 4 in. (10.2 cm) in diameter. The holes were all drilled with air, and great care was taken to not introduce foreign fluids into the test holes. As mentioned previously, Test Site No. 1 was not used because of the presence of temporary electrical equipment in the drift.

E3.2 Equipment Installation

Test holes were instrumented with pressure transducers (Geokon Model 4500-H) before the pumping began, during the pumping test, and after the pumping was completed. In addition, a transducer was placed in open air to detect underground air pressure changes that may influence measured pressure in the holes. Before data were collected, the transducers were zeroed for atmospheric pressure using a Geokon 401. All transducers were connected to a junction box, with a single line connecting the junction box to a Geokon CR-10 remote datalogger that stores data obtained from the transducers (Figure E-3-1). A computer cable connected the datalogger to a laptop computer (Toshiba Model 1200) for downloading information and for storage of data on magnetic disk.

A Bennett model air-driven piston pump was used for all tests. This type of pump allows a user-controlled discharge rate from 1.0 to 50 gallons (gal) per hour (gph) (3.8 to 189 liters per hour [Lph]). This pump is capable of very low discharge rates and uses compressed air supplied by a portable air compressor. The pump was lowered into a designated test hole,

E-11

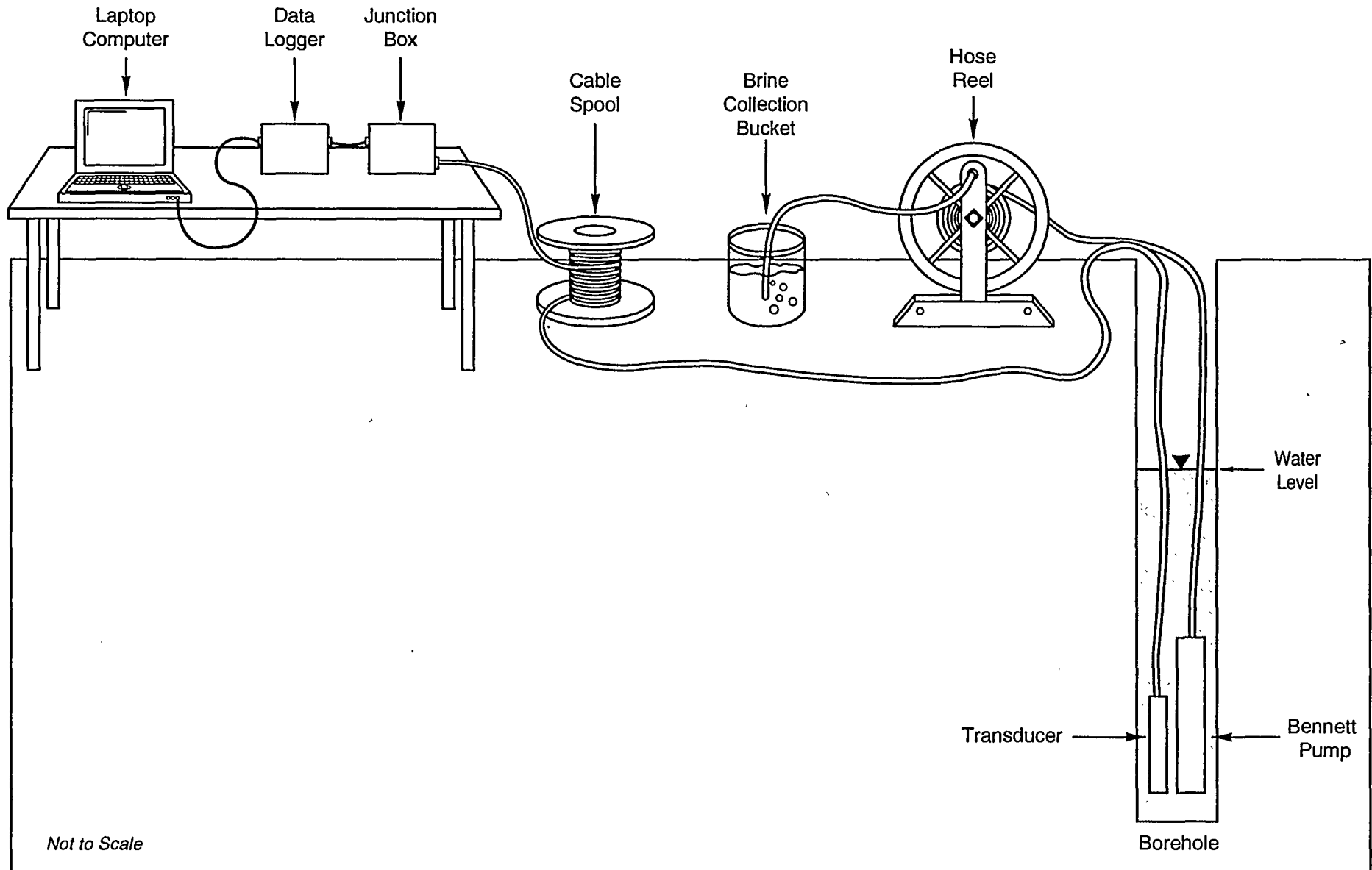

Figure E-3-1
Typical Pump Test Equipment Setup

and the water level was allowed to reach equilibrium. The flow rate was measured by pumping the brine into a 1 gal (3.78 L) bucket while measuring the time required to fill the bucket. The bucket of brine was then dumped into a 250-gal (945 L) storage tank.

E3.3 Geologic and Drilling Logs

Geological logs were prepared for each core. Cores were logged in accordance with WIPP Procedure WP 07-502, "Geologic Rock Coring Logging," (Westinghouse, 1987). In addition to the geological logs, core drilling depth logs were prepared for correlation between the holes.

E3.4 Scratcher Rod Survey

As part of ongoing investigations, Geotechnical Engineering is observing and evaluating fracturing beneath the WIPP excavation. Fracturing was characterized in the holes using standard procedures for borehole fracture investigation. A scratcher rod was used to determine the fracture location, the orientation, and the approximate size of the fractures. The results of the scratcher rod survey were recorded as part of the Excavation Effects Program.

E3.5 Hole Depths

The general condition and total depth were observed at each test hole. Table E-3-1 shows the drilled depth, the measured depth, and the date of measurement. Depths were measured using a standard metal measuring tape.

E0 at N620 Test Site. With the exception of OH71 (Figure E-2-3), which had no surface plug and was partially filled with debris, each hole was reasonably intact. Westinghouse Experimental Operations staff chipped and vacuumed out much of the debris and fluid and fluid-level equilibrium had not yet been achieved by the start of the test. All holes showed signs that the clay layers surrounding MB 139 were deforming and offsetting the test holes. The bottoms of the test holes appeared either to have filled with muck or to have started to close in at a depth of approximately 9 ft (2.75 m) and were offset. The muck in the partially filled holes may have changed the observed hydrologic response to pumping.

For some holes, the depths that were measured were somewhat different from the original depths drilled as indicated Table E-3-1. In December 1992, the Westinghouse Experimental Operations staff vacuumed all test holes to remove debris and muck. The test hole depths

Table E-3-1
Drilled and Measured Depths of Test Holes
at the E0 and W170 Test Sites

Hole Number	Test Date	Measured Hole Depth (in feet) ^a	Drilled Depths (in feet) ^a
OH59	11/9/92	10.29	10.17
OH60	11/9/92	11.25	11.33
OH61	11/9/92	10.00	10.00
OH62	11/9/92	11.25	11.32
OH63	11/9/92	9.50	9.39
OH64	11/9/92	10.20	10.70
OH65	11/9/92	9.25	9.98
OH66	11/9/92	9.00	9.15
OH67	11/9/92	9.67	9.40
OH68	11/9/92	10.42	10.68
OH69	11/9/92	6.17	10.00
OH70	10/12/92 12/17/92	8.85 8.92	8.75
OH71	10/12/92 12/17/92	9.15 9.08	9.00
OH72	10/12/92 12/17/92	9.50 9.42	8.96
OH73	10/12/92 12/17/92	9.00 9.00	8.90
OH74	10/12/92 12/17/92	9.33 9.33	9.00
OH75	10/12/92 12/17/92	7.75 8.00	7.70
OH76	10/12/92 12/17/92	9.25 9.08	9.10
OH77	10/12/92 12/17/92	8.00 8.15	7.90
OH78	10/12/92 12/17/92	9.00 8.42	9.10

^aDepths measured below drift floor surface.

were remeasured (Table E-3-1). The total hole depths measured in December 1992 are very near those recorded on the original drilling logs from January 1990.

W170 Test Site. With the exception of OH69, all test holes appeared to be fairly clean and free of muck and debris. Hole OH69 was filled with at least 3.5 ft (1.1 m) of muck. All holes appeared to be straight and did not show obvious signs of the clay layers surrounding MB 139 squeezing into the holes.

Table E-3-1 shows the measured depths of the boreholes, the as-drilled boreholes depths, and the date drilled. There were some notable differences in water levels across the test site area. Water levels were somewhat higher in the center of the W170 drift, directly in front of the core library (OH65, OH66, and OH67). The depths to water increased by almost 2 ft (0.61 m) in the interior of the core library and to an even greater extent elsewhere.

E4.0 Observations and Test Site Conditions

Thorough characterization of the hydrologic conditions present in the test areas was required before proceeding with actual pumping drawdown tests. These conditions include the number and locations of fractures, the levels of saturation, the occurrence of saturated muck on the drift floors, the structure and thickness of MB 139, and the water pressure and fluid levels in the holes prior to the tests.

Test hole drilling and installation confirmed that fractures saturated with brine occurred beneath much of the areas for both test sites. Fracture observations were made visually and with a nail probe rod (scratcher rod), as described in Section 3.4 of this report. Based on these observations, it appears that fractures and structural separations of individual layers were restricted to the anhydrite (MB 139) and the clay seams associated with MB 139. Therefore, the hydrogeologic unit within the DRZ being tested and yielding brine to the test holes is generally fractured MB 139.

Both hydrologic test sites showed variability in fluid levels in the test holes across each respective site. Such variability suggests that each test site contained separate and independent fracture systems acting as isolated brine reservoirs. Geologic logging of the drill hole cores indicate that MB 139 is not uniform in thickness nor in depth to the top or bottom

of the bed. Logging also revealed that MB 139 appears to be fractured at numerous depths, particularly in the lower one-half of the unit (Crawley et al., 1992).

The following sections describe specific observations and conditions of the E0 and W170 test site areas in more detail.

E4.1 E0 Test Site Prior to the Initial Pumping Test

The initial hydrologic test of this field program was conducted at the E0 drift test site during the period of October 8 through 14, 1992. The nine test holes at this site were preexisting, having been drilled more than three years prior to the scheduled pumping test.

Considering the history of brine use for dust control in the E0 drift, fluid levels in the boreholes were initially lower than expected, providing only about 3 to 4 ft (1 m) of saturated hole to be used in pumping. Table E-4-1 shows the measured depths to water in the test holes prior to the pumping tests. The deeper fluid levels suggested that the pumping test at this site would likely be very short in duration, if even possible.

Figures E-4-1 and E-4-2, cross-sectional views of the E0 test site, show the depths to the top and bottom of MB 139 and the depths to the standing-water column in each test hole. Fluid levels in holes OH72, OH73, OH74, OH75, and OH76 are similar and are at equilibrium near the top of MB 139 (Figure E-4-1). The depth to the top of the fluid column increases significantly to the north in hole OH77, suggesting that fractures in MB 139 may not be saturated north of the test site area. The fluid level in OH71 on the south end of the test site is somewhat lower than that in the center of the test area. However, the lower fluid level in OH71 may be the result of previously cleaning out and evacuating this test hole and does not reflect the equilibrium fluid level. Figure E-4-2 shows the cross-sectional view across the E0 drift, depicting fluid levels within or slightly above those of MB 139. Hole OH78 exhibits a lower fluid level than do OH70 and OH74, perhaps indicating that the fracture system near the east edge of the drift may not be hydraulically connected to fractures in the center of the drift.

Drilled depths and measured depths of holes shown in Figures E-4-1 and E-4-2 are often different. Muck in the holes may cause the measured depth to be less than the original

Table E-4-1
Measured Water Levels in Test Holes at the E0 Site
During the Initial Pumping Test

Hole Number	Date Measured	Depths to Water (in feet) ^a
OH70	10/12/92	4.62
OH71	10/12/92	6.83
OH72	10/12/92	4.70
OH73	10/12/92	4.95
OH74	10/12/92	4.98
OH75	10/12/92	4.94
OH76	10/12/92	5.08
OH77	10/12/92	5.90
OH78	10/12/92	6.23

^aDepths to water measured below drift floor surface.

E-17

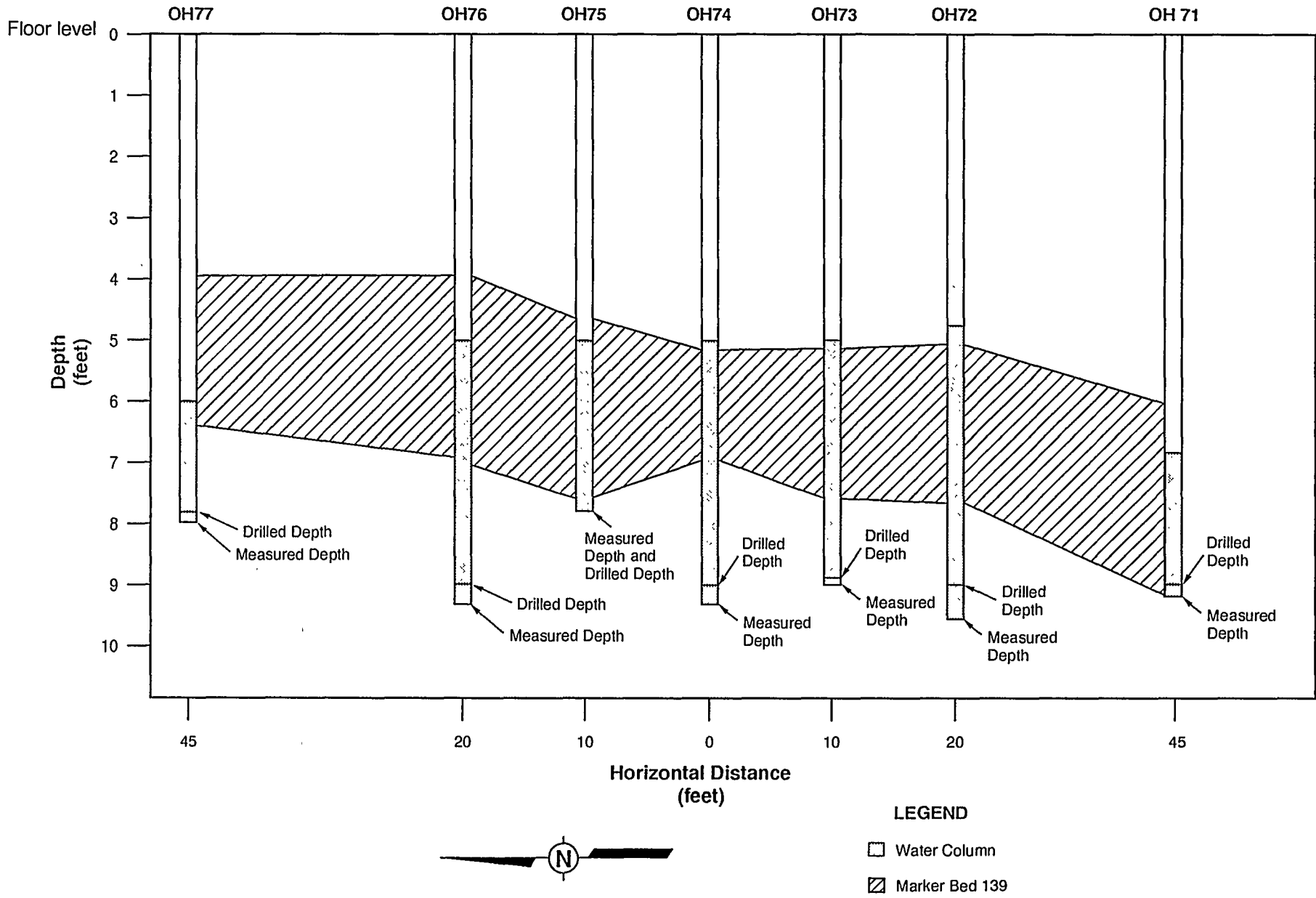

Figure E-4-1
Cross Section of Boreholes Along the E0 Drift Test Site, October 1992

E-18

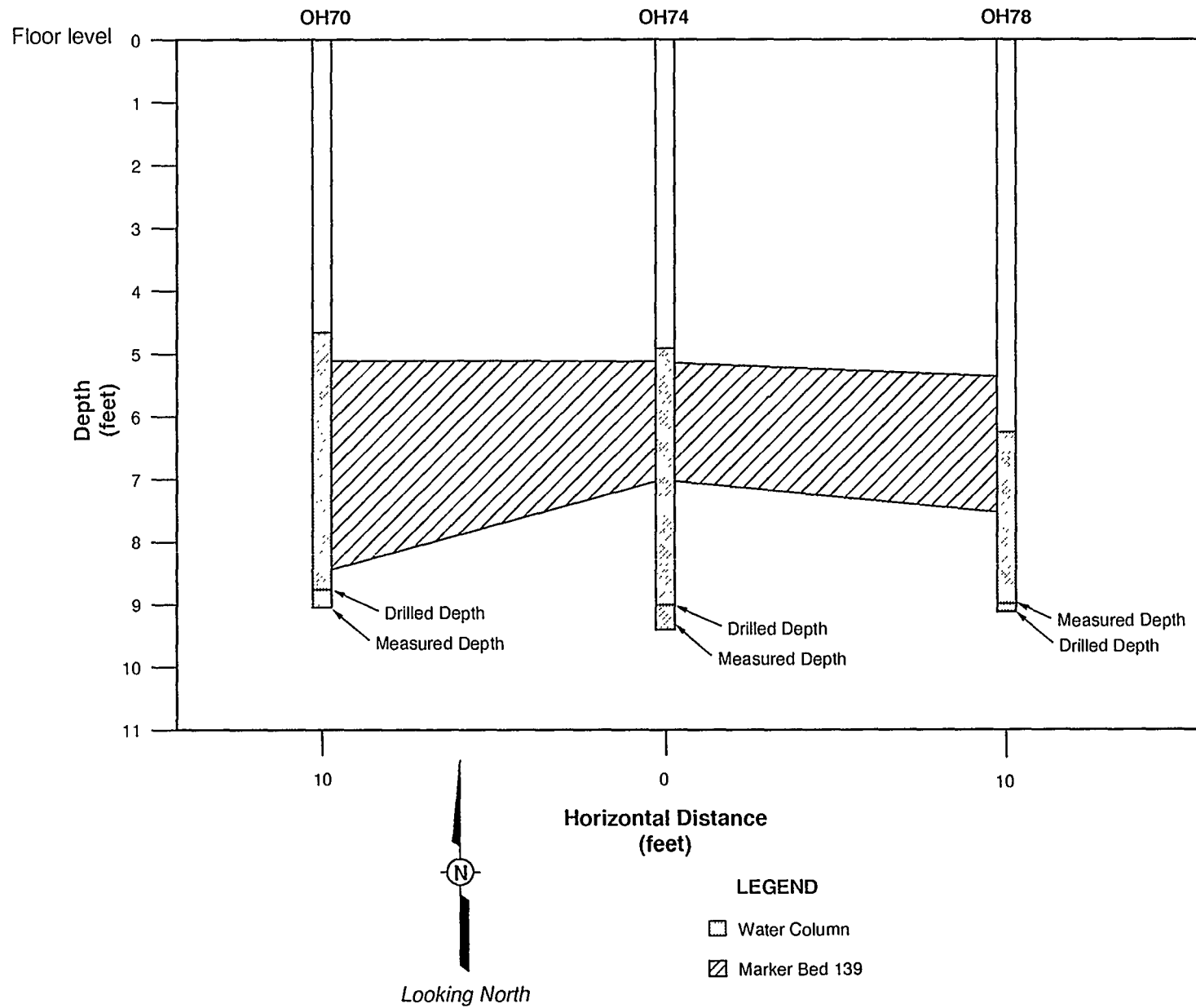

Figure E-4-2
Cross Section of Boreholes Across the E0 Drift Test Site, October 1992

drilled depth. Conversely, muck buildup on the floor of the drift (the reference point for measurements) may cause the measured depth to be greater than the original drilled depth.

Figure E-4-1 shows that MB 139 has an apparent dip to the south in this area and that the depths to the top and bottom of the bed is variable. These structural characteristics may influence fracture orientation and fluid levels.

Based on the initial observations of test hole fluid levels, it was anticipated that the planned pumping test may be short in duration, yielding limited data for hydrologic analysis. Hole OH74 was selected as the primary pumping hole for the test. Data from the preliminary step drawdown test conducted on October 12, 1992 indicated that a pumping drawdown test could be conducted at a very low flow rate (Chapter 5.0).

E4.2 W170/Core Library Test Site

The second hydrologic test of this field program was conducted at the intersection of the W170 drift and the underground core library from November 9 to 13, 1992. Eight of the eleven test holes at this site were preexisting, having been drilled more than three years prior to the scheduled test at this site. Three of the holes (OH59, OH60, and OH61) were drilled on October 19 and 21, 1992, in preparation for testing at this site.

Water levels were measured in all holes prior to any pumping activity. Water levels in holes in the W170 drift were generally 3 to 5 ft (0.91 to 1.5 m) below the drift surface, with a few exceptions (Table E-4-2). Figures E-4-3 and E-4-4 show the depths to the top and bottom of MB 139 and the depths of the standing water columns in each test hole at this site.

As shown in these two cross-sectional figures, there were some notable differences in water levels across the test site area. Water levels were somewhat higher in the center of the W170 drift, directly in front of the core storage library (OH65, OH66, and OH67). The depths to water increased by almost 2 ft (0.61 m) in the interior of the core storage library and to an even greater extent elsewhere. Two holes, OH60 and OH68, exhibited markedly different water levels. OH60, located interior to the core storage library, is a recently drilled hole, the water level may not yet have reached equilibrium, or the borehole does not intersect any brine-filled fractures.

Table E-4-2
Measured Water Levels in Test Holes at the W170 Site
During the Initial Pumping Test

Hole Number	Date Measured	Depths to Water (in feet) ^a
OH59	11/9/92	6.15
OH60	11/9/92	10.86
OH61	11/9/92	5.43
OH62	11/9/92	5.20
OH63	11/9/92	4.98
OH64	11/9/92	4.65
OH65	11/9/92	3.30
OH66	11/9/92	3.35
OH67	11/9/92	3.00
OH68	11/9/92	7.30
OH69	11/9/92	4.10

^aDepths to water measured below drift floor surface.

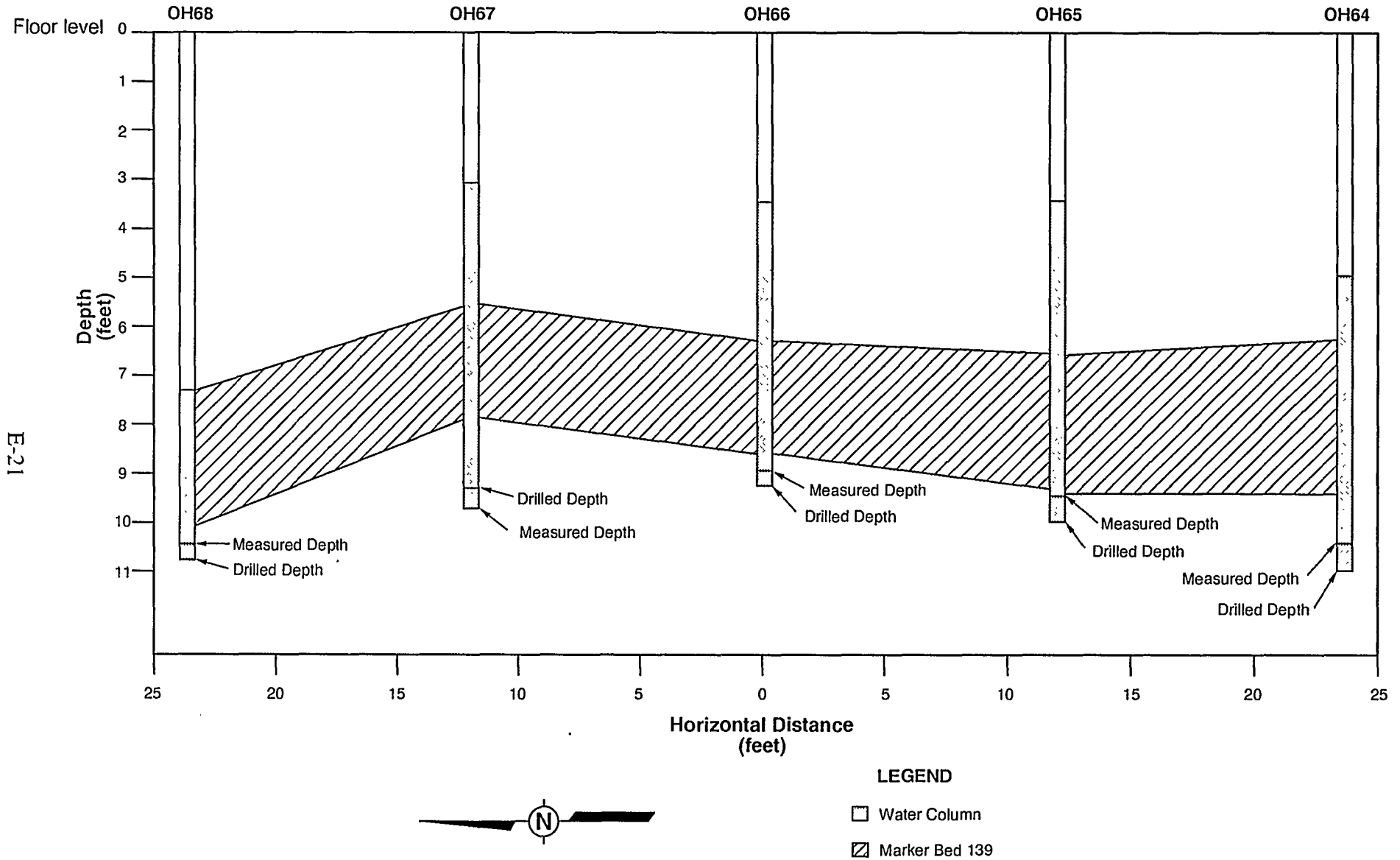

E-21

Figure E-4-3

Cross Section of Boreholes in the W170 Drift at the Core Library, November 1992

E-22

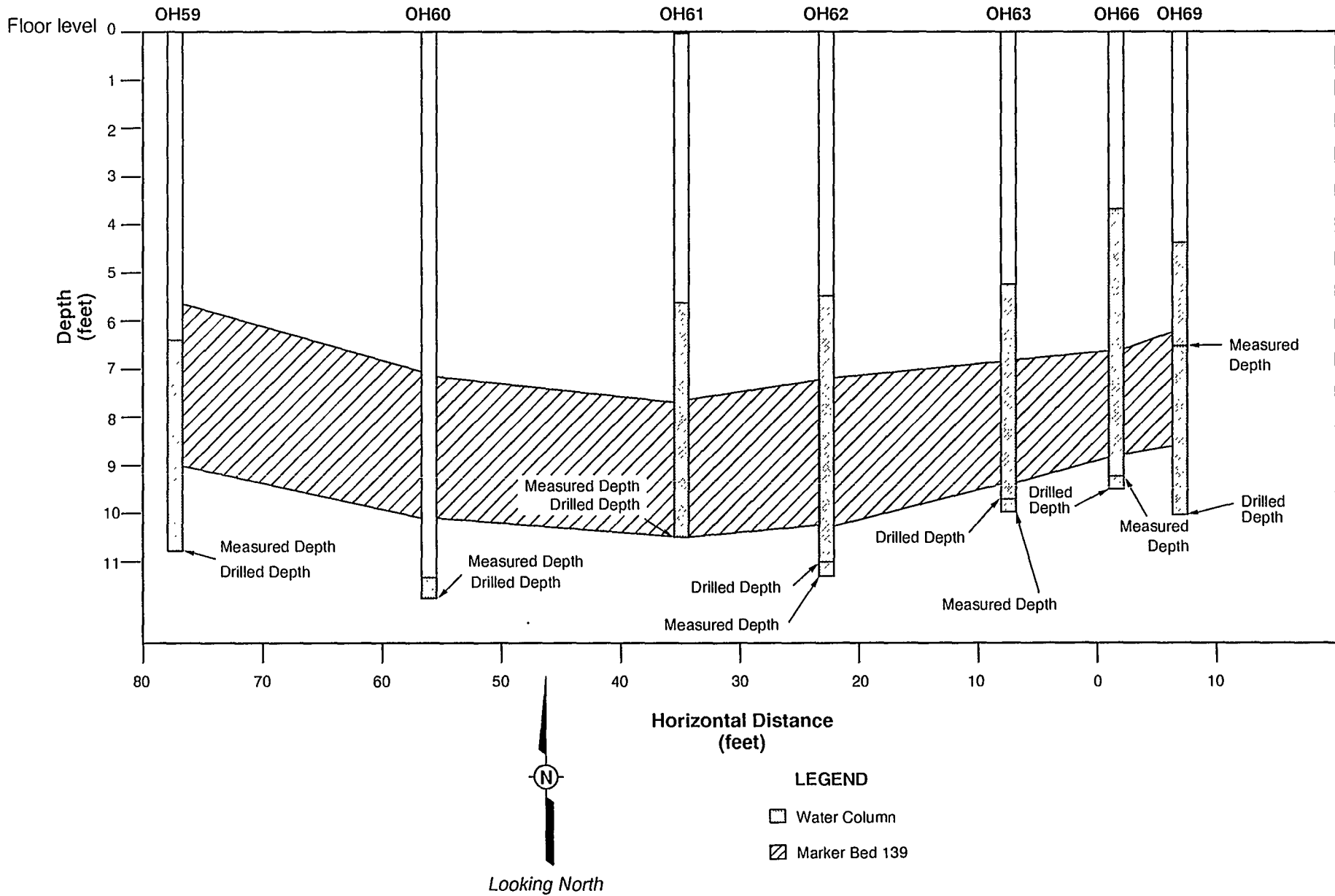

Figure E-4-4
Cross Section of Boreholes Across the W170 Drift and into the Core Library, November 1992

Hole OH66 was selected as the pumping hole for the initial test based on its location in the middle of the drift (directly in front of the entrance to the core library) and a pretest standing fluid column of approximately 5.65 ft (1.7 m). The pretest fluid columns in holes OH62, OH63, OH64, OH65, OH66, and OH67 were all greater than 5 ft (1.5 m) in length, suggesting that there would be sufficient water to conduct a pumping test of adequate duration at this site. Because of concerns about potential dewatering of the proposed pumping hole (OH66), no preliminary drawdown step test was performed for this site.

E4.3 E0 Test Site Prior to the Retest at This Site

The third and final field tests for the hydrologic testing of the fractured part of the DRZ project were conducted from December 14 through 17, 1992, at WIPP. These tests were repeats of the initial test conducted at the site located in the E0 drift in front of the N620 alcove from October 9 through 14, 1992.

As described in Section E4.1, the test holes at this site appeared to contain some semiconsolidated muck, which may have had an impact on the results from the initial test. Prior to the second test attempt at this site, the holes were reconditioned by removing some of the muck with a vacuum system. The reconditioning effort also removed all of the brine standing in the holes at that time. The fluid levels in the test holes partially recovered prior to the December 1992 field test period.

The total depth of each hole was measured, and each hole bottom felt solid and free of muck. With the exception of OH76, which has a major offset at approximately 6 to 7 ft (1.8 to 2.1 m) beneath the floor of the drift, all holes appeared to be generally straight. This offset closes about one-half of the hole and made instrument installation difficult.

Figures E-4-5 and E-4-6 show the depths of the top and bottom of MB 139 and the depths of the standing water columns in each test hole at this site in December 1992. The depths measured in December 1992 are very near the depths recorded on the original drilling logs in January 1990 (Table E-3-1). Water levels, measured in all holes prior to any pumping activity, ranged from 6.10 to 8.55 ft (1.86 to 2.61 m) below the drift floor surface (Table E-4-3). There were some notable differences in water levels between holes OH76 and OH77 and the other holes at the test site. All of the holes, except these two, had very similar depth-to-water measurements. Holes OH76 and OH77 had water levels approximately 2 ft

(0.61 m) deeper than the other test holes. The standing fluid column in all holes was less than 3 ft (0.91 m).

Figures E-4-5 and E-4-6 show that during the December 1992 retest period, the fluid levels in MB 139 were much lower than those measured in October 1992 (Figure E-4-1 and E-4-2). The large decrease in fluid levels may be in response to the removal of fluid from the holes during cleaning in December 1992. The lower fluid levels measured in October suggest that the area may not have fully recovered from the hole reconditioning. However, it is also possible that the continued removal of brine from test holes at the E0 drift site may be locally depleting the available fluid reservoir.

Based on the shorter standing fluid column in the test holes, it was anticipated that the pumping test might be shorter in duration than the initial test at this site. Hole OH74, which was selected for the initial test here in October 1992, was also selected in December 1992 as the primary pumping hole for the test.

E5.0 Hydrologic Testing and Data Collection

The main objective of the field testing program was to determine local hydrologic parameters for the fractured part of the DRZ at the E0 and W170 drift test sites using standard pumping drawdown-type testing techniques. Additional goals include developing and refining testing techniques and collecting baseline hydrologic data from comparable old and new areas of the repository. To achieve these objectives, the two test sites were instrumented with downhole pressure transducers to monitor local fluid pressures in the fractured zone beneath the drifts. For the pumping drawdown tests, a Bennett model air-driven piston pump was installed in the selected test hole to provide user-controlled discharge rates from approximately 1 to 50 gph (3.8 to 189 Lph). This type of pump is capable of very low discharge rates and uses compressed air from a portable compressor (Figure E-5-1).

The pressure transducer data were stored in random access memory using Geokon CR-10 remote dataloggers. These data were transferred to magnetic disk for analysis and evaluation using the appropriate computer software. The procedure for conducting pumping drawdown-type hydrologic testing included collecting background water pressure and water-level data prior to the test, evaluating local fluid-level trends, selecting the pumping hole, pumping equipment installation, performing a preliminary step drawdown test, estimating the

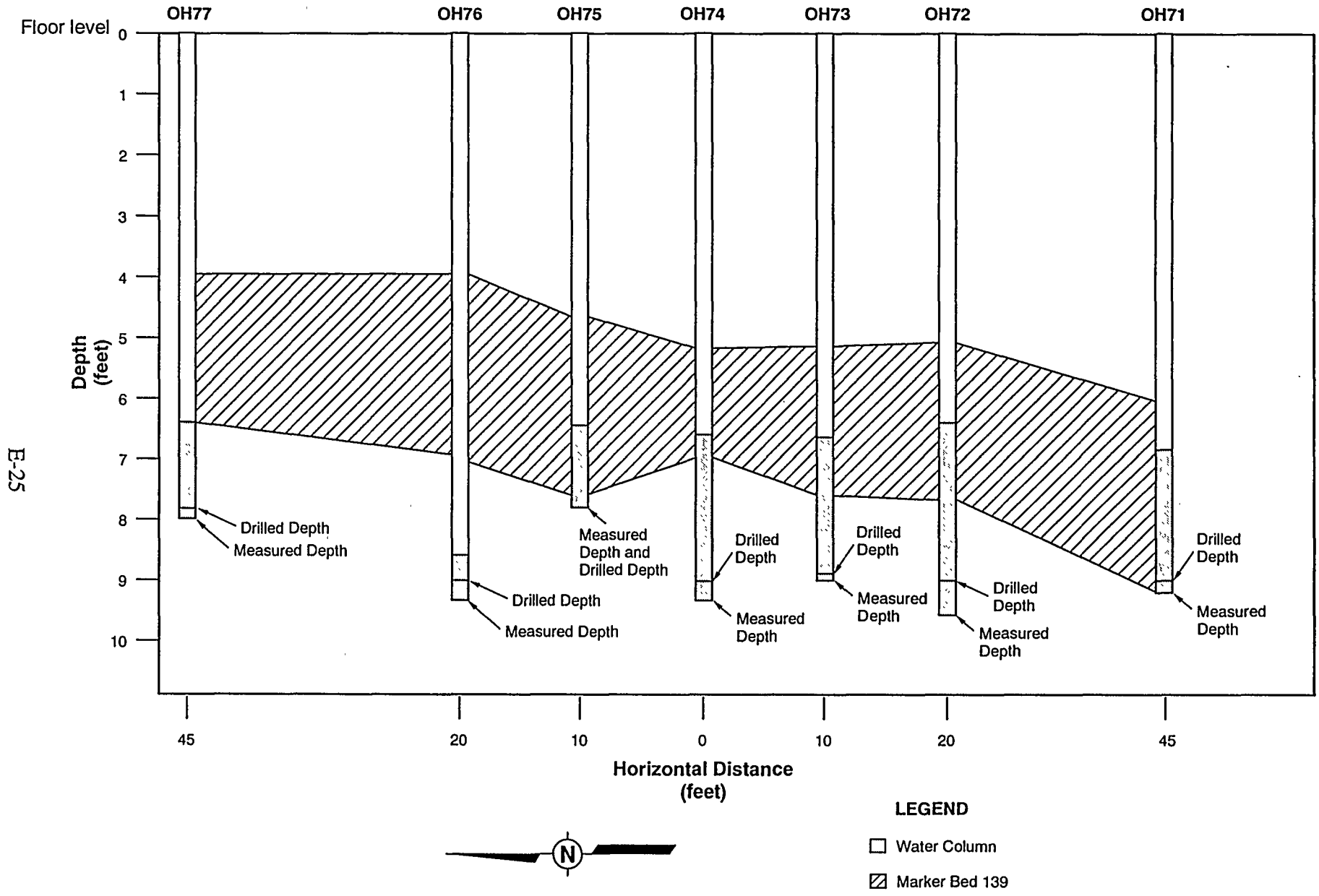

E-25

Figure E-4-5
Cross Section of Boreholes Along the E0 Drift Test Site, December 1992

E-26

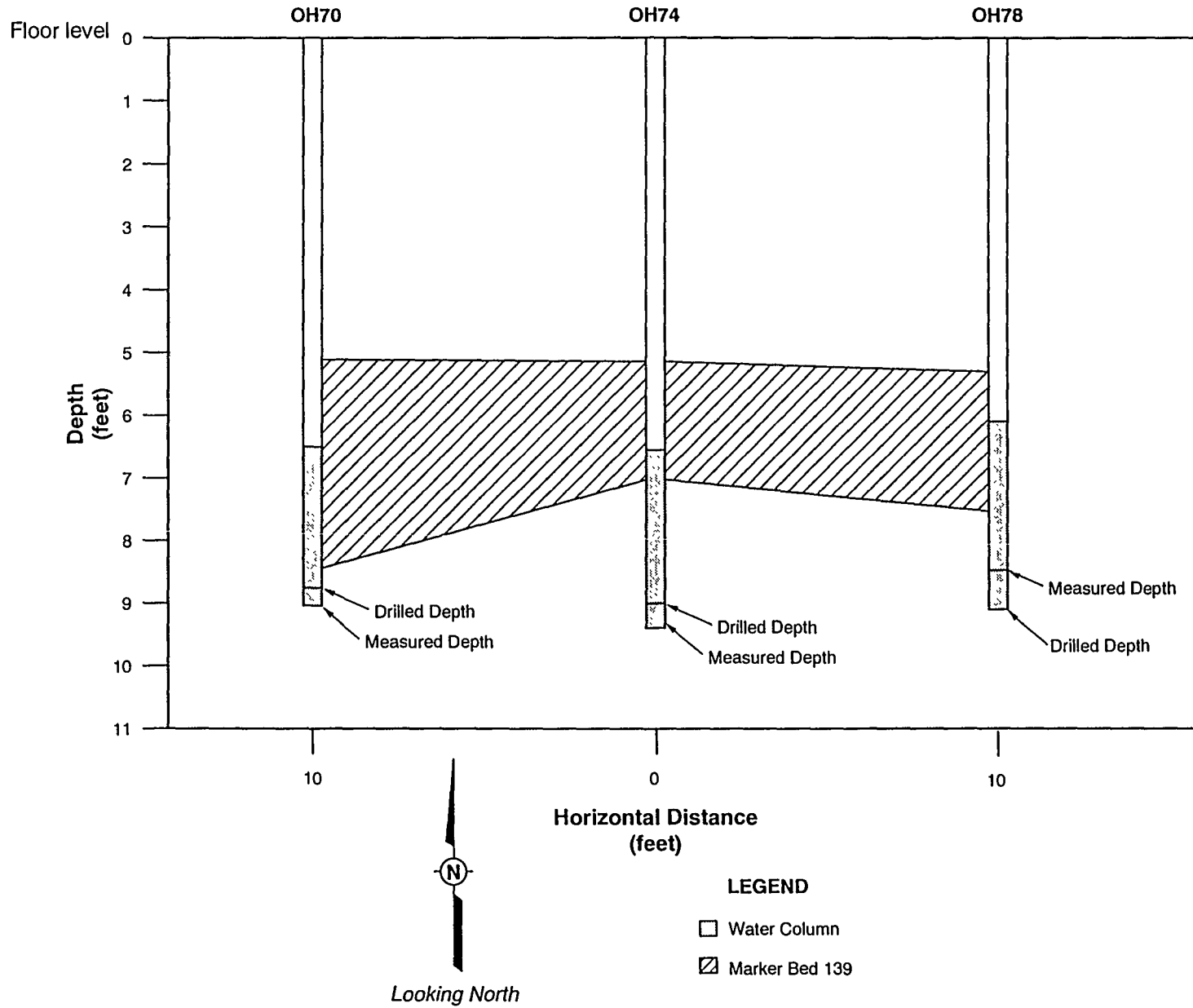

Figure E-4-6
Cross Section of Boreholes Across the E0 Drift Test Site, December 1992

Table E-4-3
Measured Water Levels in Test Holes at the E0 Site
During the Second Pumping Test

Hole Number	Date Measured	Depths to Water (in feet) ^a
OH70	12/14/92	6.50
OH71	12/14/92	6.85
OH72	12/14/92	6.35
OH73	12/14/92	6.75
OH74	12/14/92	6.70
OH75	12/14/92	6.70
OH76	12/14/92	8.55
OH77	12/14/92	8.40
OH78	12/14/92	6.10

^aDepths to water measured below drift floor surface.

301681.009.00.000/rd A21
1/26/95

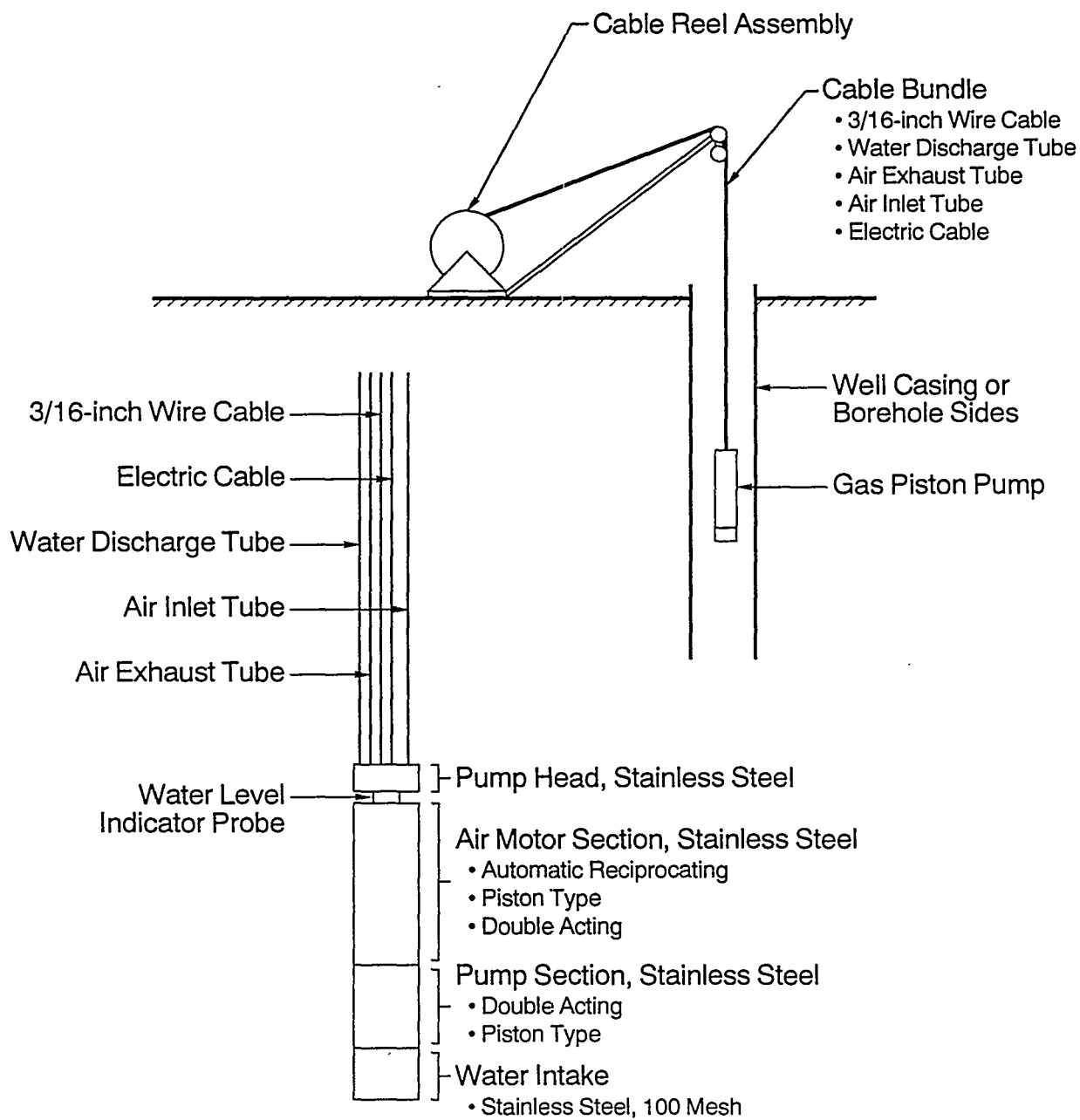

Figure E-5-1
Schematic of Gas-Driven Piston Pump (Bennett Model 1800)
with Exploded View of Cable Bundle

appropriate flow rate, conducting the pumping test for as long as possible, and monitoring recovery of fluid levels. The sections below present the results of the pumping drawdown tests at the E0 and W170 drift test sites.

E5.1 Initial Pumping Drawdown Test at the E0 Drift Site

Background water pressure and water-level data were collected at the E0 test site to provide some definition of long-term trends, and changes regarding test parameters and for comparison with test results. Background data collection began October 12, 1992, in all holes at the test site.

Figure E-5-2 shows hydrographs of fluid pressures in holes OH70, OH73, OH74, and OH75, from the initial instrumentation through completion of the pumping drawdown test. These hydrographs show the response to pumping OH74. Pumping commenced at 10:32 a.m., October 13, 1992. The hydrograph also shows that the fluid levels in the holes that responded to pumping did not recover to their pretest levels by the time data collection was terminated. This observation suggests that the fluid reservoir being pumped through OH74 may be limited and that pumping from the test area may be dewatering the available fluid locally from the fracture systems.

Figure E-5-3 shows hydrographs of fluid pressures in holes OH71, OH72, OH76, OH77, and OH78 from the beginning to the end of the pumping test in OH74. These holes show very limited, if any, drawdown response to pumping, indicating that the test area may have separate, unconnected fracture systems that are at least partially saturated with brine.

On October 12, 1992, a preliminary step drawdown test was conducted at the E0 Test Site. OH74 was pumped at several flow rates to establish a discharge rate that could be maintained for at least several hours. The final flow rate was adjusted to approximately 8.7 gph (32.9 Lph), producing a drawdown that would appear to allow pumping for the required duration. The test was terminated after less than 1 hour of pumping, and the area was allowed to recover overnight. The hole that was pumped and the surrounding holes had only partially recovered by the beginning of the full-scale pumping drawdown test the following morning.

E-30

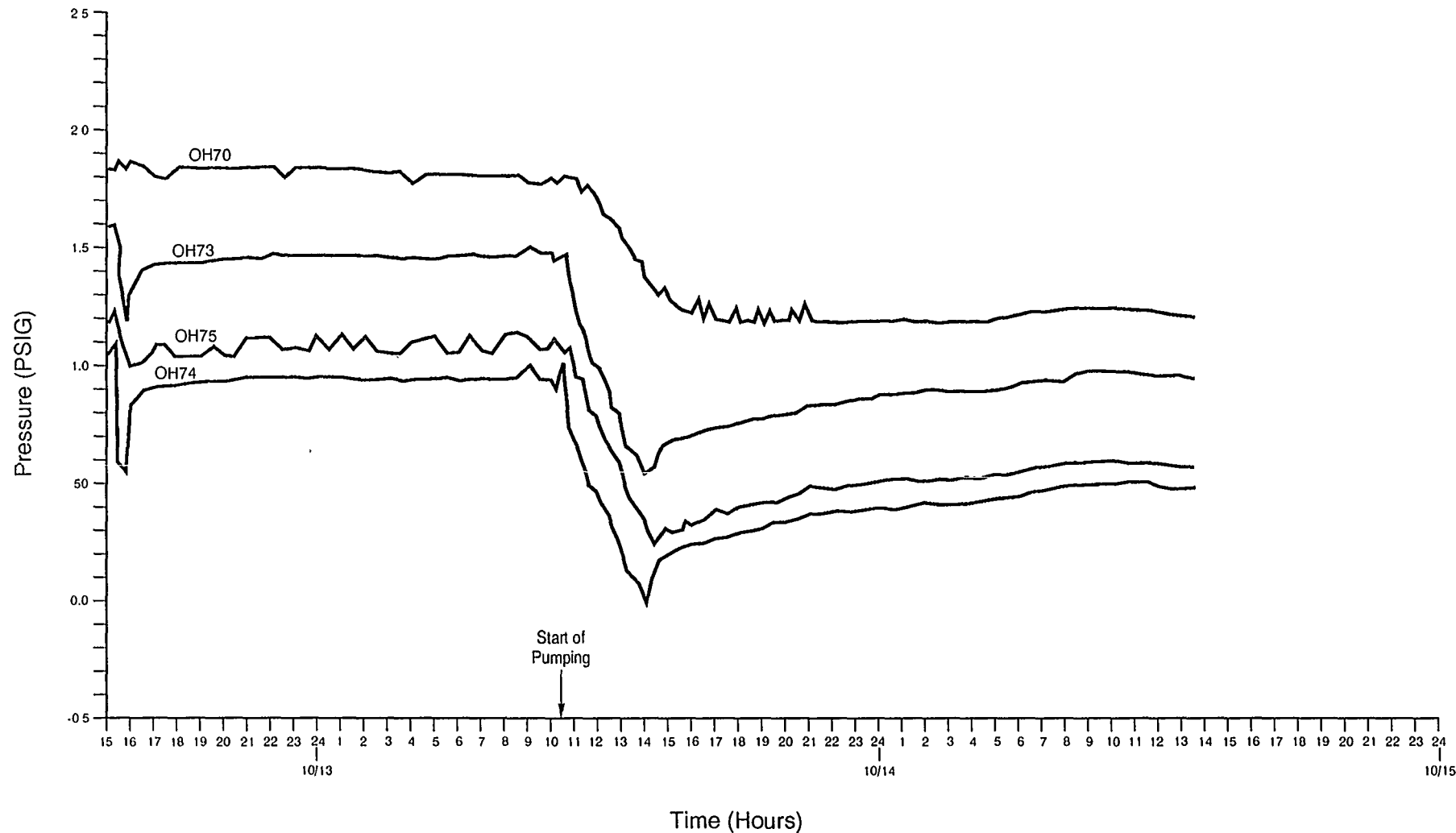

Figure E-5-2
Hydrographs of the E0 Site Test Holes OH70, OH73, OH74, and
OH75 Through the End of the Pumping Test, October 1992

E-31

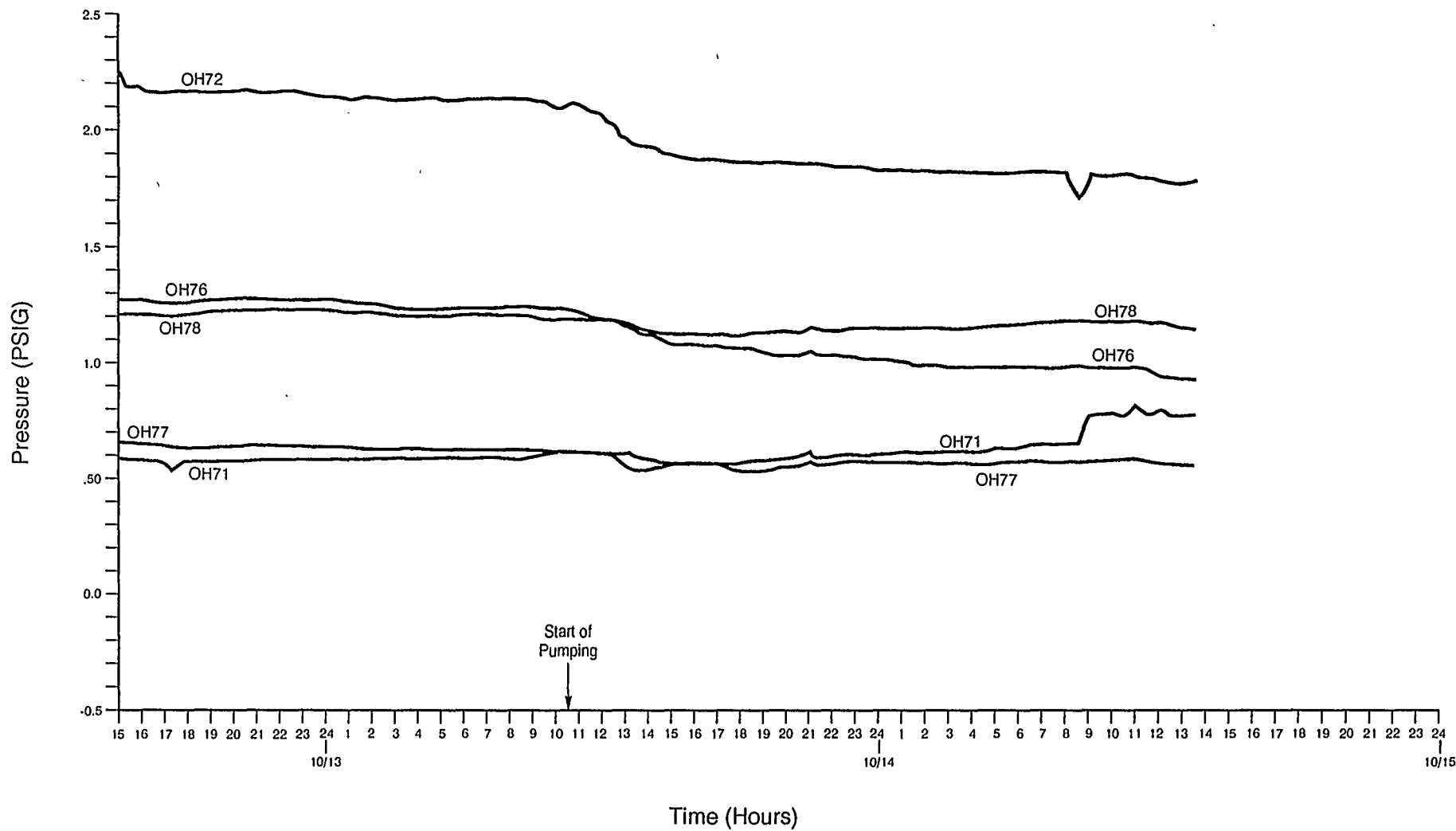

Figure E-5-3
Hydrographs of the E0 Site Test Holes OH71, OH72, OH76, OH77, and
OH78 Through the End of the Pumping Test, October 1992

A pumping drawdown-type test was conducted on October 13, 1992, again using hole OH74 as the pumping hole. The test started at 10:00 a.m., but the pump intake soon became clogged with mud. The pump was removed from the hole, and the intake was cleaned. The pump was reinstalled, and the test hole was allowed to recover for 30 minutes (min). During the second pumping attempt at 10:32 a.m., all equipment functioned properly.

The pumping discharge rate was continuously monitored and adjusted until a flow rate of approximately 6 gph (22.5 Lph) was attained. The actual measured pumping rate ranged from 7.57 to 5.14 gph (28.6 to 19.5 Lph), with an average of 6.06 gph (22.9 Lph). The test lasted for approximately 3 hours and 37 min. During the test, fluid levels in all holes were continuously monitored using transducers and a datalogger.

E5.1.1 Test Performance and Results

The pumping discharge rate became stable after approximately 20 min. The discharge rate was slightly variable throughout the test but did not significantly influence the steady drawdown achieved in the pumped hole and surrounding holes. Test hole fluid pressures were monitored at 1-min intervals throughout the test.

The pumping test was terminated at 2:10 p.m., when the fluid level in the pumped hole dropped to a level below the pump intake. The pump was then turned off, and the recovery phase was started. All pumping and monitoring equipment performed well throughout the test.

Drawdown of fluid levels was observed in most of the test holes surrounding OH74 during the pumping period. Only holes OH71 and OH77 showed no measurable response. These two holes, located at either end of the line of holes along the axis of the E0 drift, are the most distant holes from the pumping center. Figure E-5-4 shows the distribution of drawdown response at the site during the initial test in October 1992.

The hydrographs in Figures E-5-2 and E-5-3 show that OH70, OH73, and OH75 are the only holes to respond significantly to pumping OH74. Holes OH72 and OH76 showed only a limited response to pumping, and OH78 shows only a very slight long-term lowering of downhole fluid pressure. Holes OH71 and OH77 showed no response.

301681.009.00.000/ld A24
1/26/95

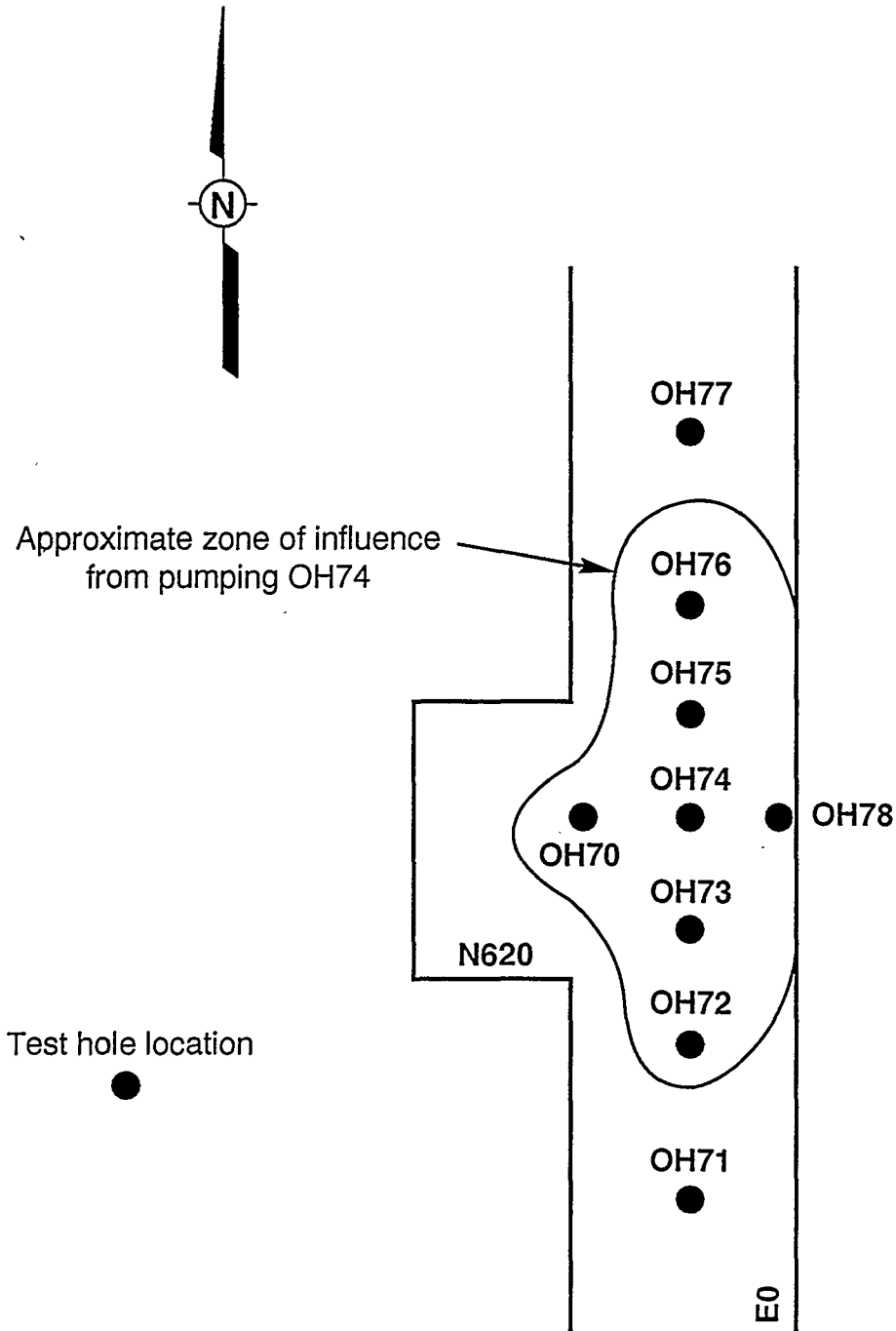

Figure not to scale

Figure E-5-4
Test Holes at the E0 Site Showing Response to Pumping OH74
During the Initial Test at This Site, October 1992

All holes showing some response to pumping exhibited limited fluid-level recovery upon termination of pumping, including the pumping hole OH74. The limited recovery, combined with the distribution and degree of drawdown response, suggests that the local fractured reservoir is limited in radial extent and that fracture systems may not be well interconnected. Both OH70 and OH78 are located only 10 ft from the pumped hole, but their drawdown responses are significantly different. Hole OH70 responded well to pumping, while OH78 did not. The drastic difference in response may indicate that the fracture system intercepted by OH78 (near the E0 drift wall) is not connected to the system intercepted by the other test holes in the middle of the E0 drift. The fracture system in the middle of the E0 drift is also possibly prominent beneath the N620 alcove because of the effect of the alcove excavation itself. The testing results also suggest that the fractures in MB 139 at the intersection of the E0 and N620 are fairly well connected and that the connection dissipates as one moves away from the intersection down the E0 drift or toward the drift wall opposite the alcove.

Long-term fluid-level monitoring was not conducted to determine whether the test hole fluid levels had completely recovered with time. Therefore, no firm conclusion can be made as to the degree of potential dewatering of the fracture systems that occurred during the pumping test.

E5.1.2 Pumping Test Analysis

The aquifer test design and analysis computer software package AQTESOLV (Geraghty and Miller, 1989) was used to determine the hydrologic properties of the fractured zone at the E0 test site. The drawdown data from observation test holes OH70, OH73, OH75, and OH72 and pumping hole OH74 were evaluated using the computer software package. The Jacob and the Theis methods (Lohman, 1972) were used to determine transmissivity and storage coefficients (observation holes only) in the holes that responded to pumping.

Figures E-5-5 through E-5-9 show semilog and log-log plots of drawdown-versus-time data for the five wells listed above. The drawdown curves allowed analysis by Jacob and the Theis methods and generally showed linear plots of drawdown versus time and a good fit to Theis-type curves. The calculated transmissivity for the four observation holes, analyzed using both the Theis and the Jacob methods, ranged from 0.7 to 9.9 square feet per day (ft²/day), with an average of 3.7 ft²/day. The storage coefficients for the observation holes

ranged from 0.0004 to a maximum of 0.0034, indicating that the fracture system is at least partially confined. Transmissivity, calculated from the data for pumping hole OH74, was 3.8 ft²/day for both Theis and Jacob methods (Figure E-5-9). No storage coefficient can be calculated for the pumping hole.

Both the transmissivity and storage coefficient values, as calculated by the program, agree to within an order of magnitude for all test holes analyzed. The results of the pumping test analysis indicate that the transmissivity of the fractured zone beneath the E0 drift test site appears to be uniform (for those holes responding to pumping OH74). The calculated transmissivity for hole OH72 (Figure E-5-6) is somewhat greater (but by less than a factor of 2X) than those calculated for OH74, OH73, and OH75. The value is well within the error range of the testing and analysis methods, indicating that the transmissivity at OH72 is consistent with transmissivities calculated for the rest of this test site.

The analysis suggests the fracture system beneath the intersection of the drift and alcove at the test site is hydraulically connected and has similar hydraulic characteristics. The data also show that the fracture system acts as a porous medium. It is noted that these methods require the assumption that the aquifer is infinite. The fracture system tested at this site probably does not meet this requirement. Also, the testing generally did not provide enough data to curve-fit for more than one log cycle; therefore, the reported analytical results may be in violation of this requirement. However, the test results do provide some semiquantitative estimates of the local hydrologic characteristics of the fracture systems.

Figures E-5-5 through E-5-9 show prominent changes in slope of the drawdown-versus-log time plot for these test holes. This change in slope may indicate that the cone of depression produced by pumping encountered a low-permeability boundary or an area void of brine-filled fractures. Changes in the drawdown slope for holes OH70, OH73, and OH74 occurred between 80 and 150 min into the test. The apparent no-flow or low-permeability boundary conditions observed in these plots are consistent with the other hydrologic data resulting from this program and support the conclusion that, at the E0 test site, there are separate and hydraulically unconnected fracture systems saturated with brine.

OH70

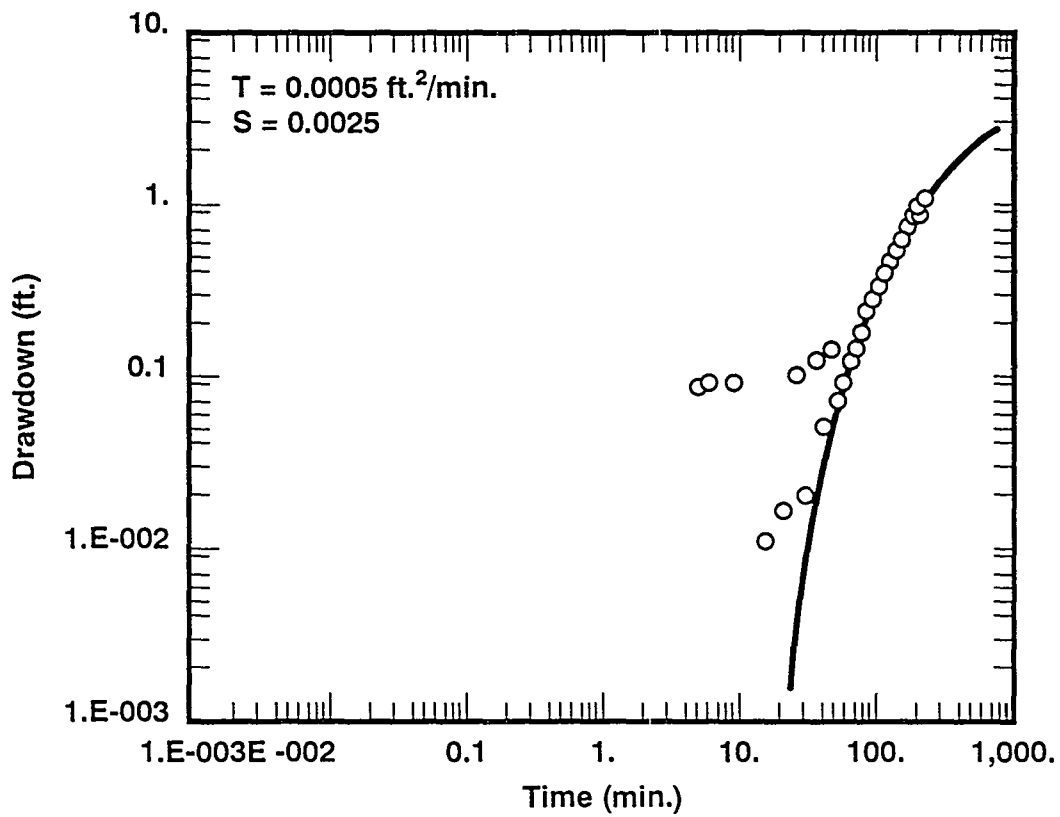
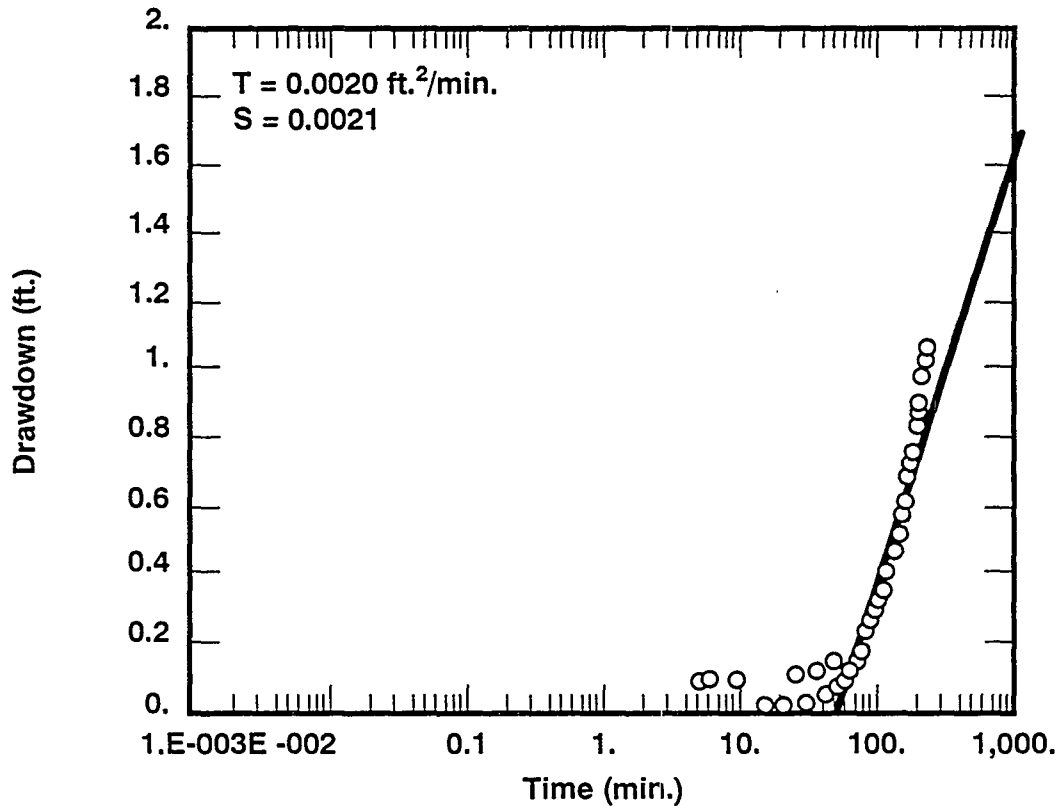

Figure E-5-5
 Semilog and Log-log Plots of Drawdown
 Versus Time for Observation Hole OH70

301681.009.00.000/1/d A25 1/26/95

301681.009.00.000/1d A26
1/26/95

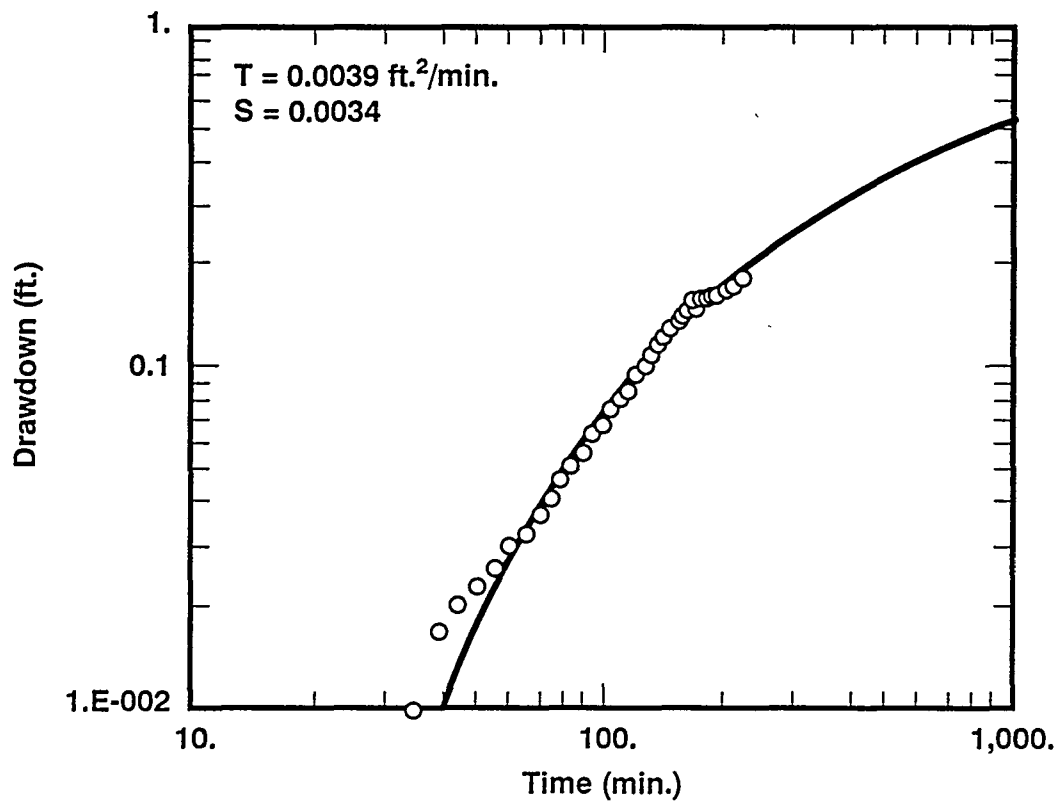
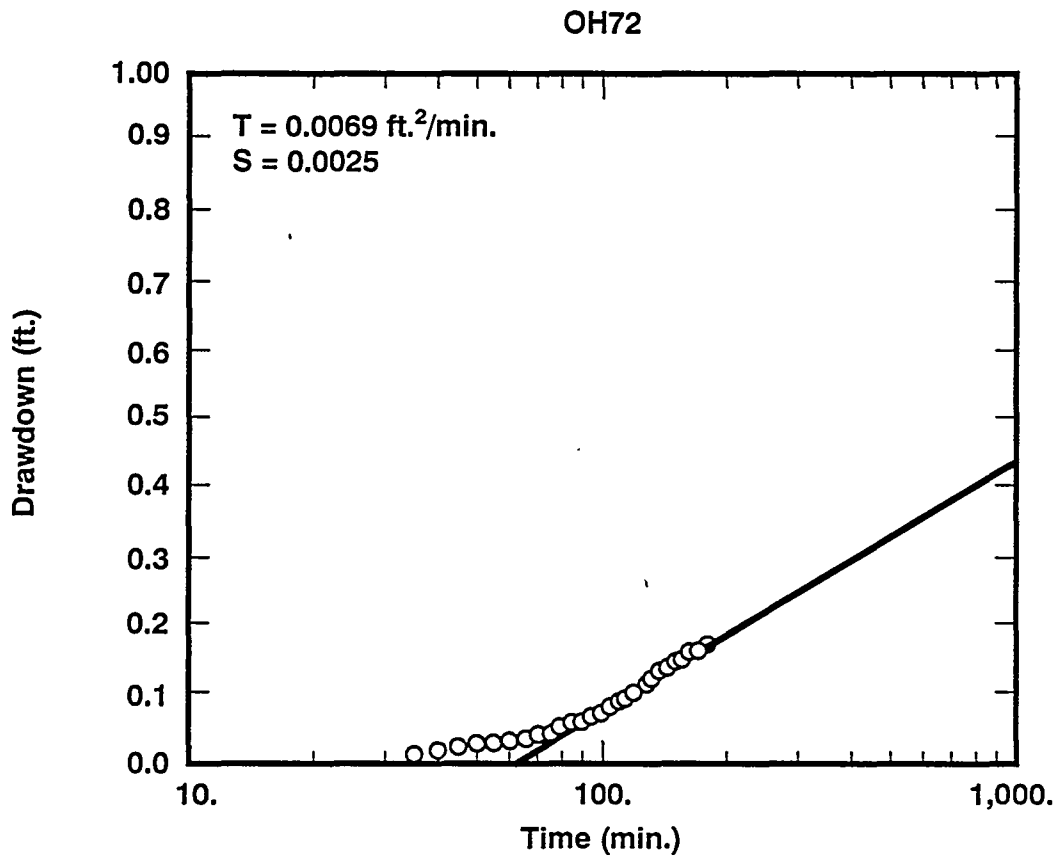

Figure E-5-6
Semi-log and Log-log Plots of Drawdown
Versus Time for Observation Hole OH72

OH-73

301681.009.00 000/ld A27
1/26/95

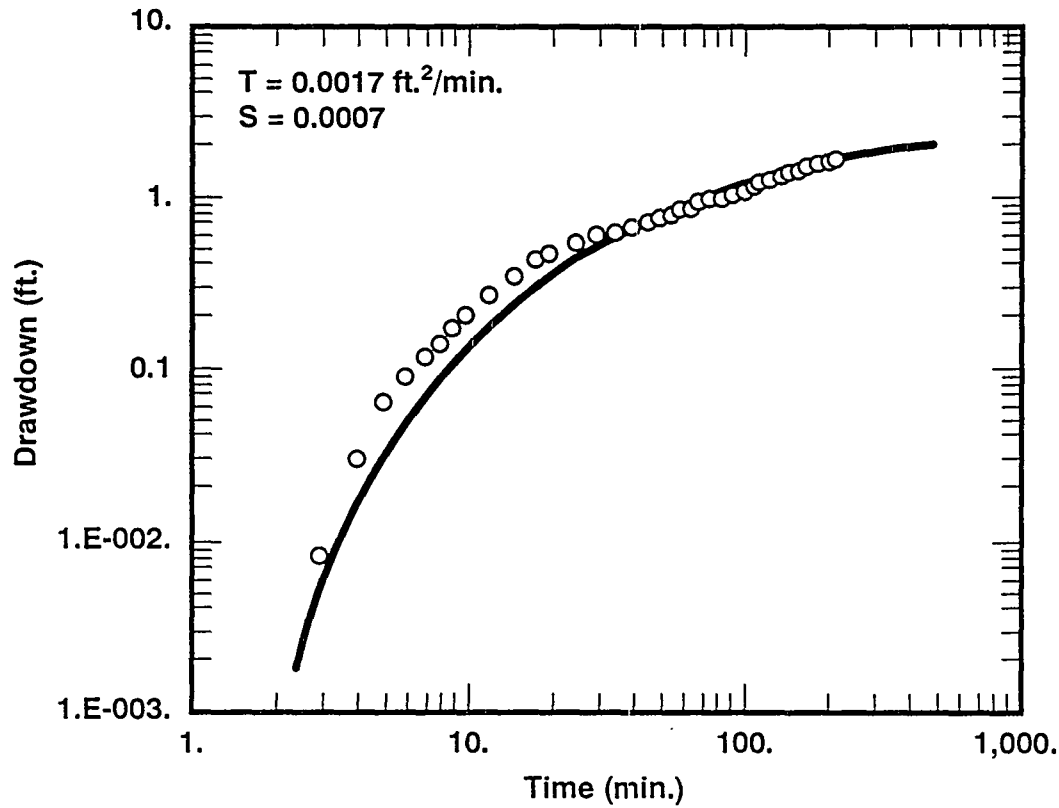
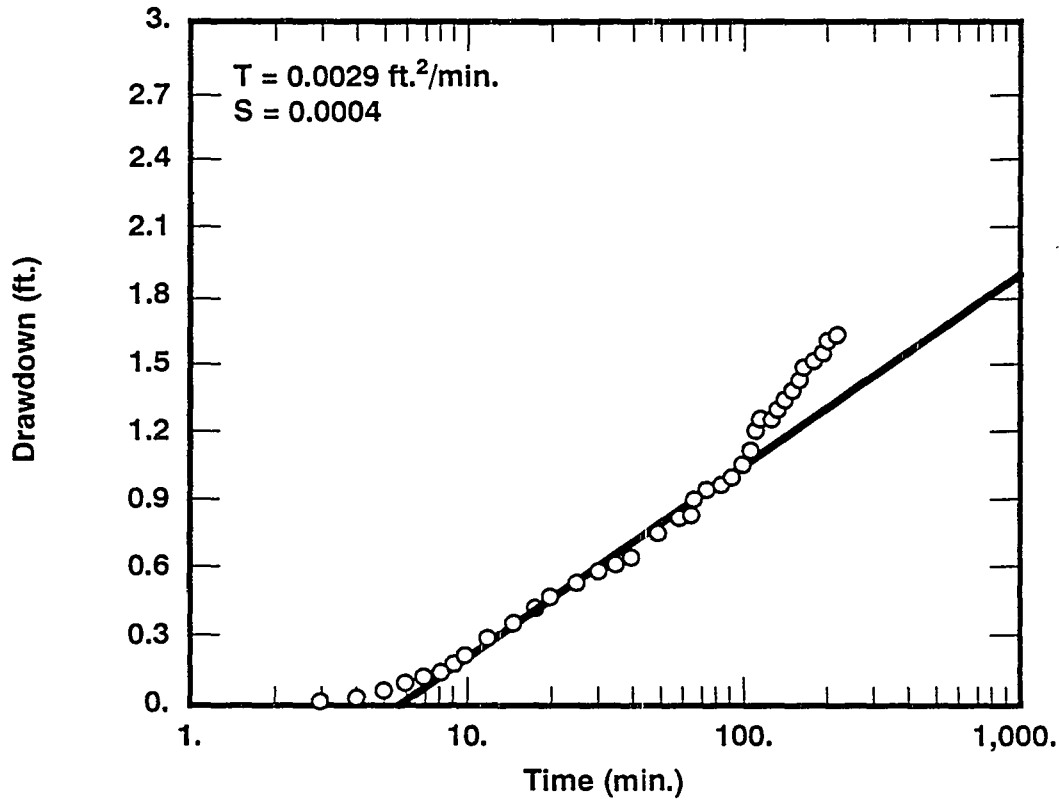

Figure E-5-7
 Semilog and Log-log Plots by Drawdown
 Versus Time for Observation Hole OH73

301681.009.00.000/lid A28
1/27/95

OH75

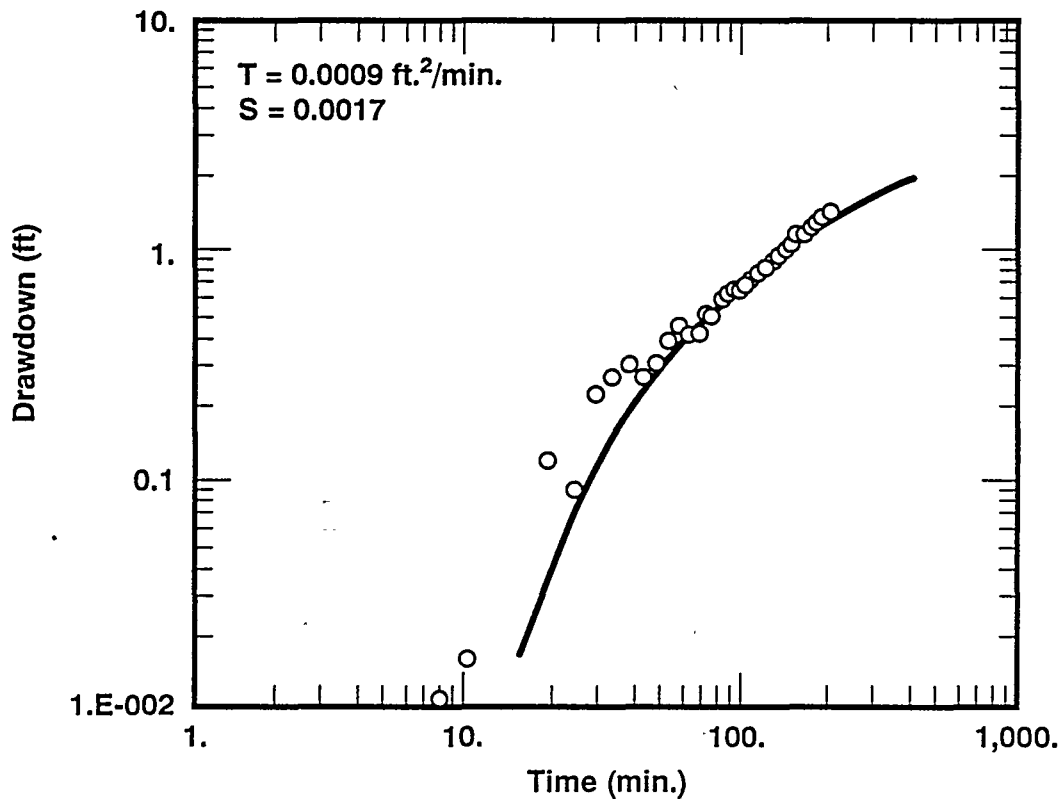
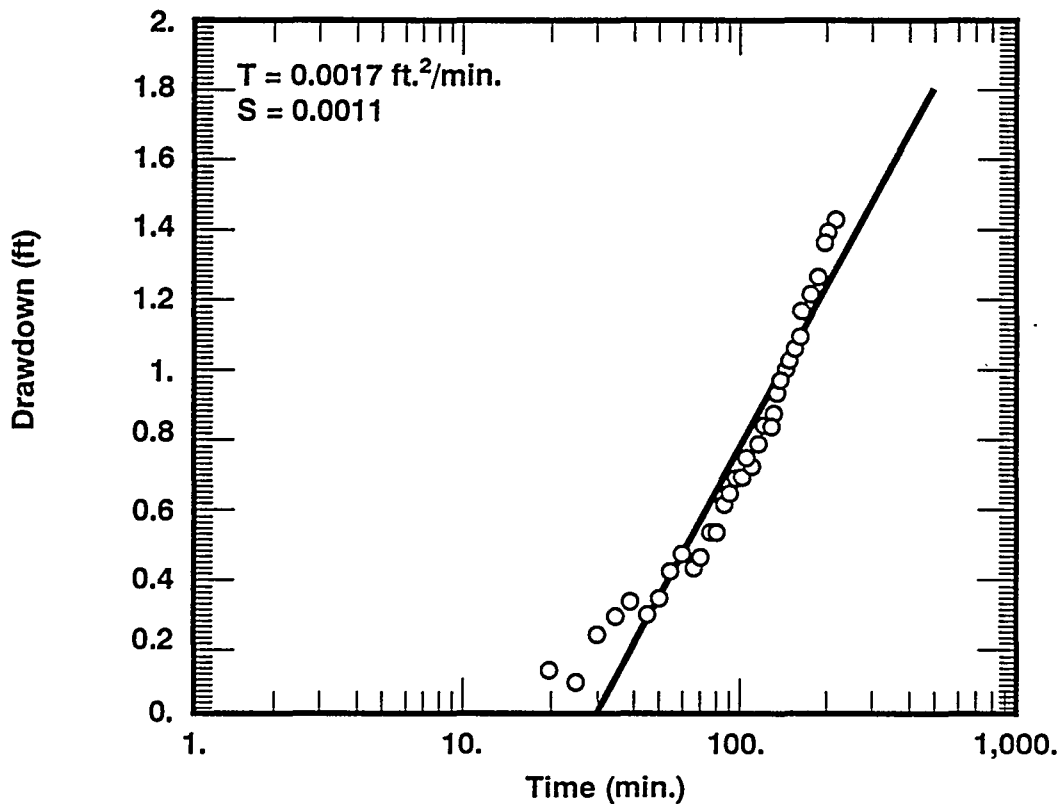

Figure E-5-8
Semilog and Log-log Plots of Drawdown
Versus Time for Observation Hole OH75

301681.009.00.000/ld A29
1/27/95

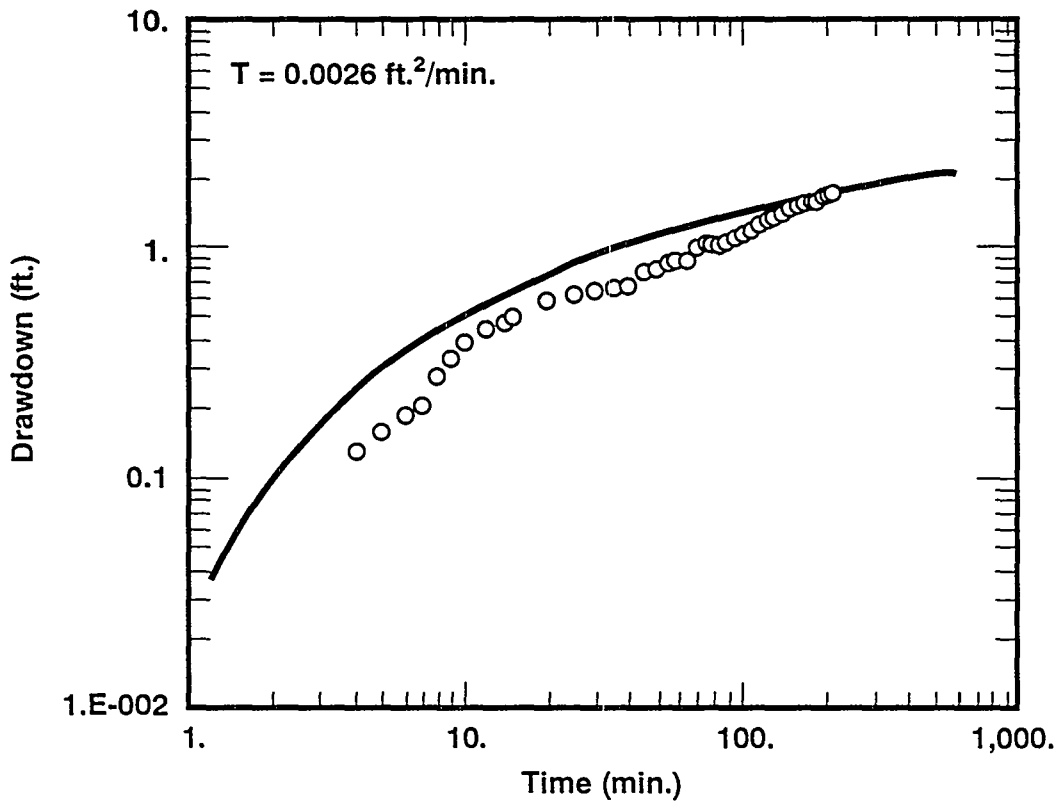
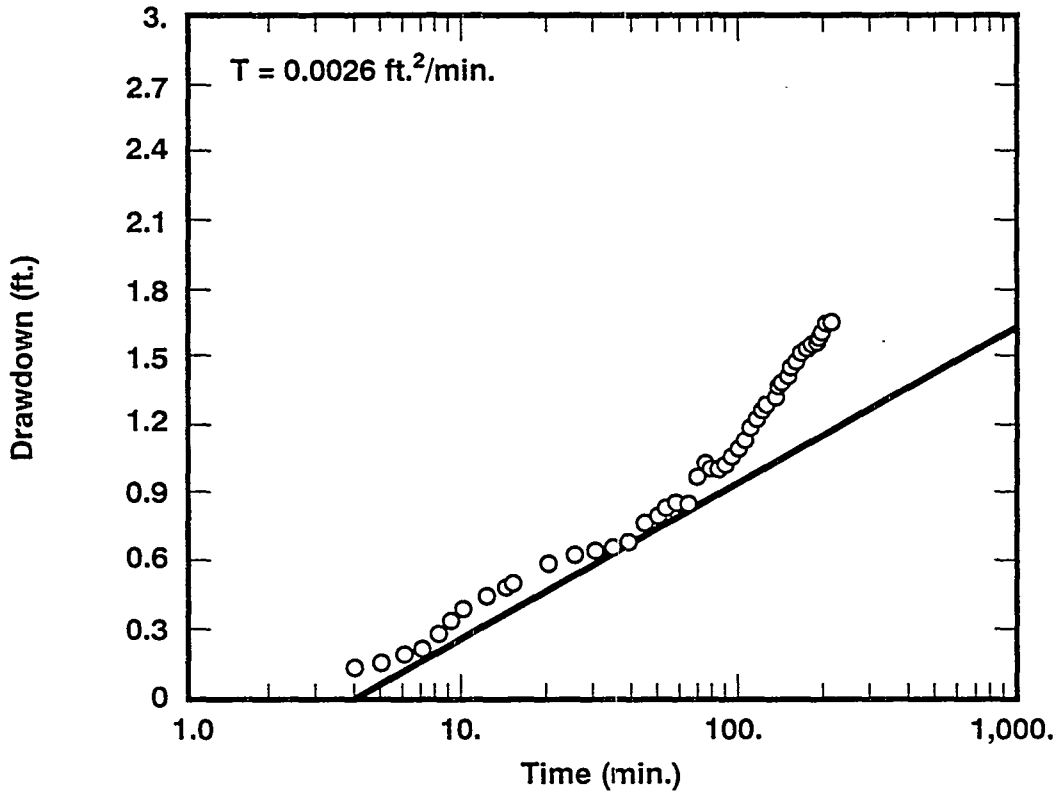

Figure E-5-9
Semilog and Log-log Plots of Drawdown
Versus Time for OH74 (Pumphole)

E5.2 Initial Pump Test at the Core Storage Library (W170) Site

The second in a series of three fractured zone pumping tests was conducted during the week of November 9 through 13, 1992. This test was performed at the intersection of the W170 drift and the underground core library.

Background water pressure and water-level data were collected to provide some definition of long-term trends and changes regarding test parameters and for comparison with test results. Background data collection began on November 9, 1992, in all holes at the test site, with the exception of OH60, which was not instrumented.

Figures E-5-10 and E-5-11 show hydrographs of fluid pressures in all holes (with the exception of OH60) from the initial instrumentation through completion of the pump test. These hydrographs show limited response to two different pumping episodes. Figure E-5-10 shows that the first pumped hole, OH66, did not recover from pumping and the limited response of the surrounding holes. Figure E-5-10 also shows that the second pumping hole, OH62, was slowly recovering before the transducer was pulled. These observations suggest that the fractured fluid reservoirs are limited and probably isolated from each other.

Figure E-5-11 shows hydrographs of fluid pressures in holes OH59, OH61, OH64, and OH68 through the end of the second pumping test. These holes, with the exception of OH61, which is adjacent to the second pump hole, show very limited (if any) response. This indicates some fracture connection between the two holes but limited connection elsewhere.

The pumping drawdown test, using OH66 as the initial pump hole, began at 11:00 a.m. on November 10, 1992. The pump was turned on at 11:00 a.m., and brine was routed to a bucket with a 1-gal graduate scale. The initial flow rate was calculated at 13.3 gph (50.3 Lph). The flow rate was adjusted, and two additional readings were taken for an average flow rate of 9 gph (34 Lph). Less than 3.5 gal (13.2 L) were pumped before the hole became dry. The water level reached the pump intake level at approximately 11:28 a.m., and the pump was left on until 11:45 a.m. to clear the pump tubing. Scan rates were changed back to 30-min intervals for overnight recovery data collection.

On November 11, 1992, a second pump test was attempted using OH62 as the pumped hole. The pump was installed at approximately 8:35 a.m. The water level in OH62 was allowed to

E-42

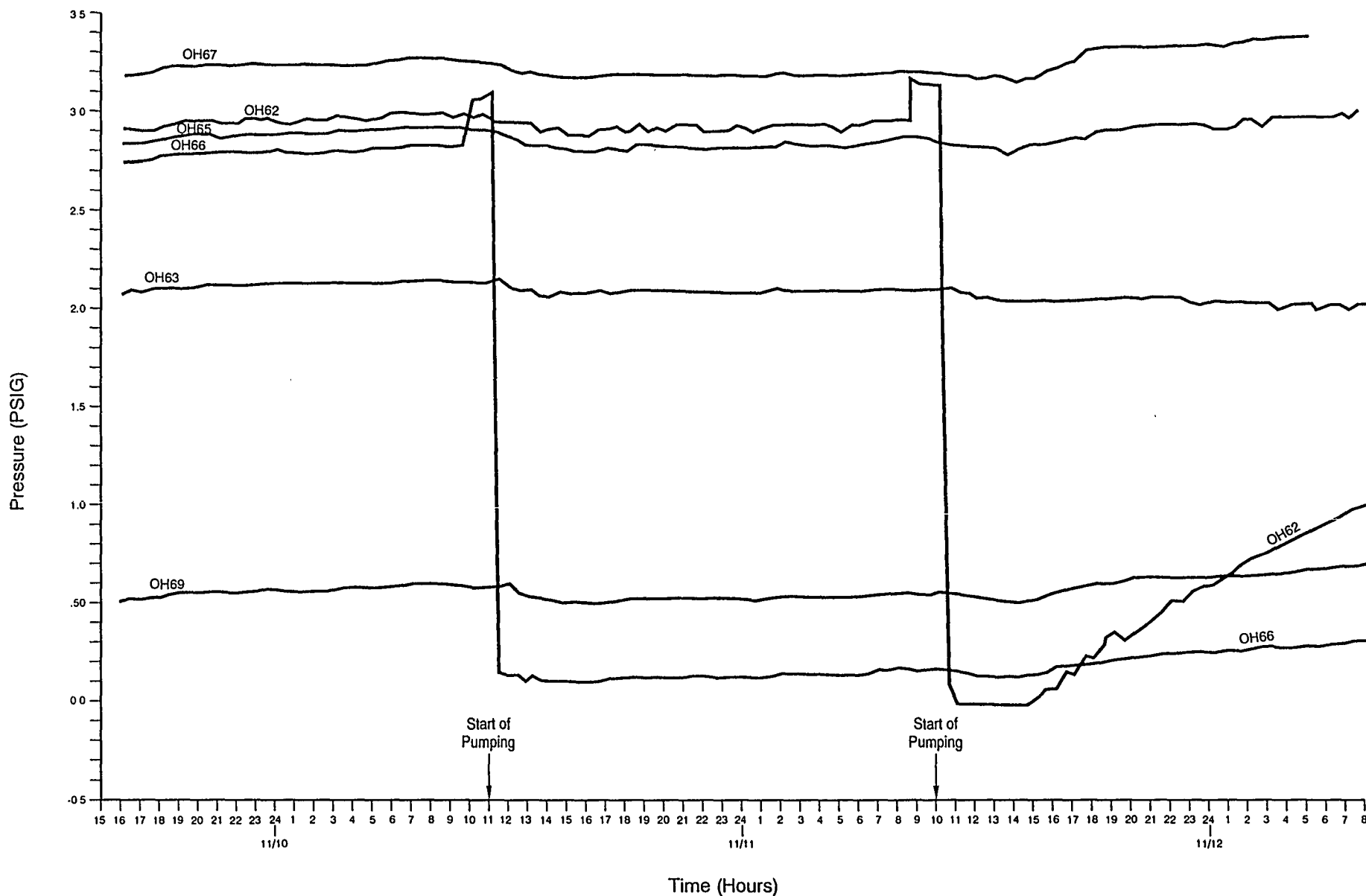

Figure E-5-10
Hydrographs of the W170 Site Testholes OH62, OH63, OH65, OH66, OH67, and OH69 Through the End of the Pumping Test, November 1992

E-43

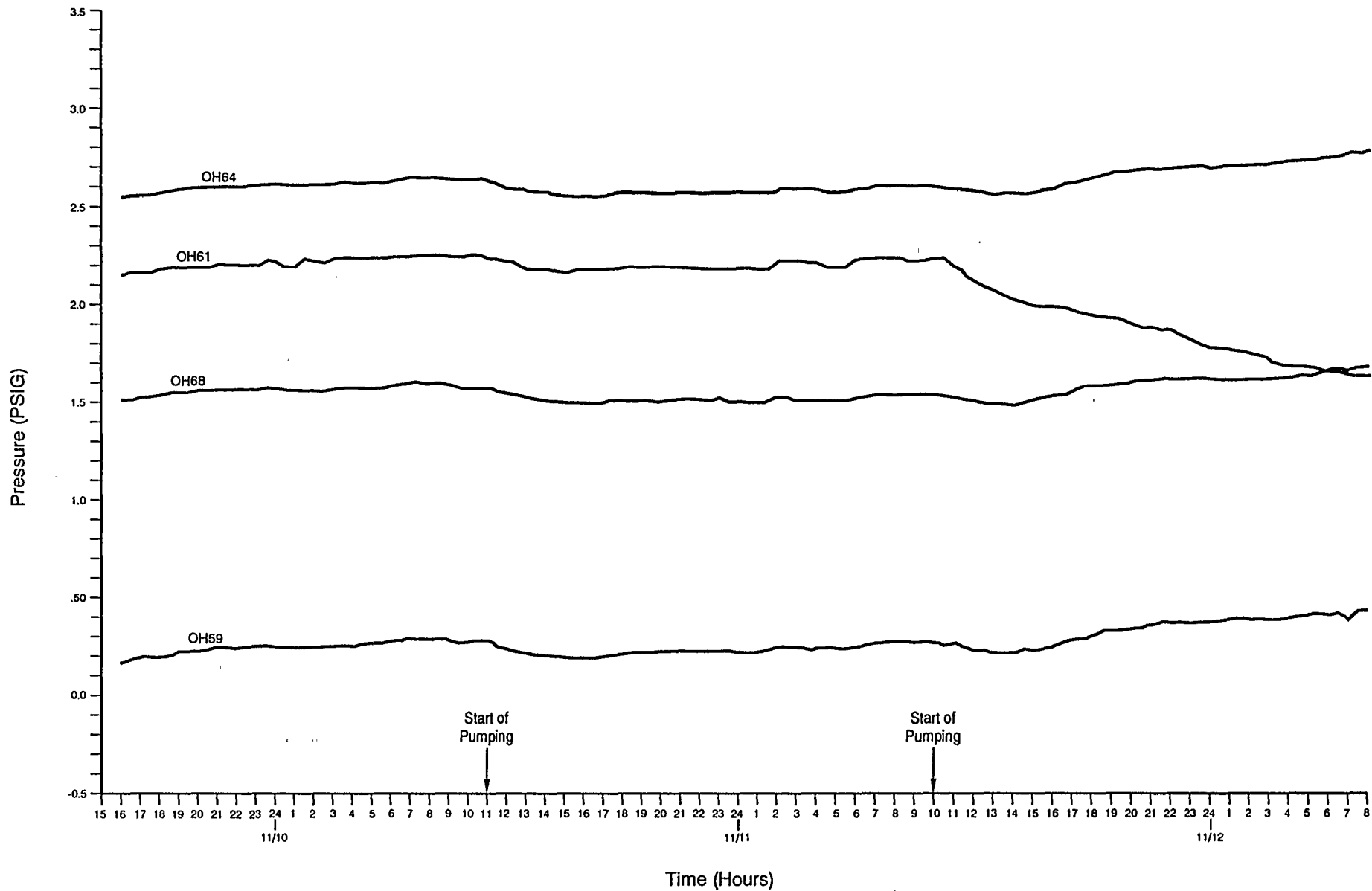

Figure E-5-11
Hydrographs of the W170 Site Testholes OH59, OH61, OH64, and OH68 Through the End of the Pumping Test, November 1992

reach equilibrium for approximately 90 min after pump installation. The scan rate was changed from 30-min to 1-min intervals to accommodate rapid water-level changes that might occur during pumping. Pumping was initiated at 10:00 a.m., with a starting flow rate of 4.8 gph (18.2 Lph). The flow rate was increased to 6 gph (22 Lph). Two additional flow rates were taken before OH62 became dry at 11:00 a.m. Average flow rate during the approximately 1-hour test was 4.8 gph (18.2 Lph). Scan rates were changed from 1-min intervals during the pump test to 30-min intervals for overnight recovery data collection. The hydrographs in Figures E-5-10 and E-5-11 show that the pump test holes (OH62 and OH66) showed the only significant response to pumping. The other holes showed very limited or no response at all. OH62 showed fairly rapid recovery after the hole was pumped dry, while OH66 showed no recovery response after being pumped. OH59, OH63, OH64, OH65, OH67, OH68, and OH69 showed very little response (Figures E-5-10 and E-5-11).

Long-term fluid-level monitoring was not conducted to determine whether the test hole fluid levels completely recovered with time. Therefore, no firm conclusion can be made as to the degree of the potential dewatering of the fracture systems that occurred during the pumping tests. Hole OH66 exhibited limited fluid-level recovery upon termination of pumping. The limited recovery, combined with the distribution and degree drawdown, suggests that the local fractured reservoir is limited in volume and that fracture systems are marginally interconnected.

Response to OH62 pumping was limited to the holes toward the interior of the core library (Figure E-5-12). The hole adjacent to OH62 (OH61) showed significant response, as demonstrated in Figure E-5-11. OH63, located only 5 ft (1.5 m) away, showed no response to OH62 pumping, indicating a very limited fracture system confined to the alcove and not connected to the older W170 drift.

The hydrologic data generated from pumping OH66 and OH62 were inadequate for performing aquifer test analysis. Therefore, no analysis other than the evaluation of fracture relationships and drawdown was attempted.

The third pumping drawdown test was conducted at the E0 drift test site (Figure E-2-2) during the period of December 14 through 17, 1992. This field effort was performed as a retest of the initial test conducted here in October 1992. The purpose of the retest was to

301661.009.00.000/ld A32
1/27/95

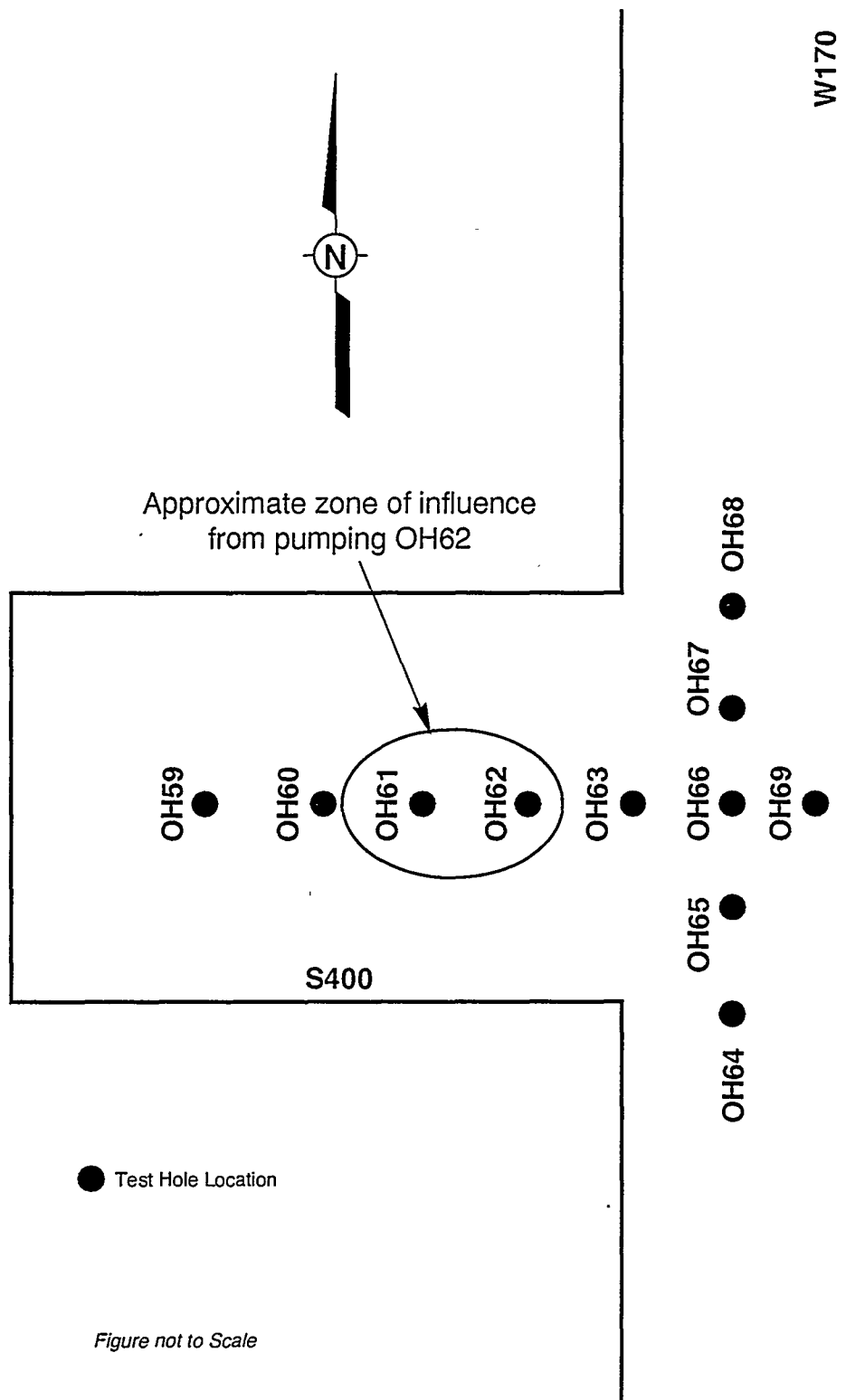

Figure E-5-12
Test Holes at the W170 Site Showing Response to Pumping OH62,
November 1992

determine whether reconditioning of the test holes would enhance the water-yielding characteristics of the holes, as well as the surrounding fractured zone. However, the reconditioning effort removed most of the brine from the test holes, and their fluid levels had not fully recovered by the time this test was initiated. Test hole reconditioning including chipping and vacuuming muck and fill material from the sides and bottoms of the test holes.

For this final test, three separate holes were pumped during individual pumping episodes. Initially the centrally located hole, OH74, was used as the pumping hole, as it was during the first test at this site. On the following day, holes OH72 and OH71 were used as pumping holes. In each effort, the selected hole was pumped dry within 2 hours or less, indicating that the fractured zone was not yielding brine to the pumped hole at an adequate rate to keep up with the pumping.

As with the initial test at this site, all holes were instrumented with pressure transducers, and background pretest water-level data were recorded. These fluid-level data are continuous through the end of the pumping tests. Background fluid-level data collection began on December 14, 1992, in preparation for the pumping test scheduled for the following day.

Figures E-5-13 and 5-14 show hydrographs of test holes OH71, OH72, OH73, OH74, OH70, OH75, and OH78 through the end of all three pumping tests. These hydrographs show that any significant response to pumping OH74 (the first of the three holes pumped during this test period) is limited to OH70, OH73, and OH75. These three test holes are the closest to the pumped hole. However, review of the hydrographs shows that there was at least a minor response to pumping in most of the holes where a response was observed during the initial test in October 1992. The hydrographs also show that fluid levels had not completely recovered by the time that data collection was terminated.

The pumping drawdown-type test was conducted on December 15, 1992, using OH74 as the pumping hole. The test began at 12:00 p.m., attempting to achieve a flow rate of approximately 4.5 gph (17 Lph). The pumping discharge rate was continuously monitored and adjusted until the desired flow rate was attained. The 4.5-gph (17-Lph) flow rate was selected because it was lower than that used during the October test and could possibly prolong pumping and, therefore, generate more data for analysis. The actual pumping rate varied from 4.19 to 5.84 gph (15.9 to 22.1 Lph), with an average of 4.70 gph (17.8 Lph).

E-47

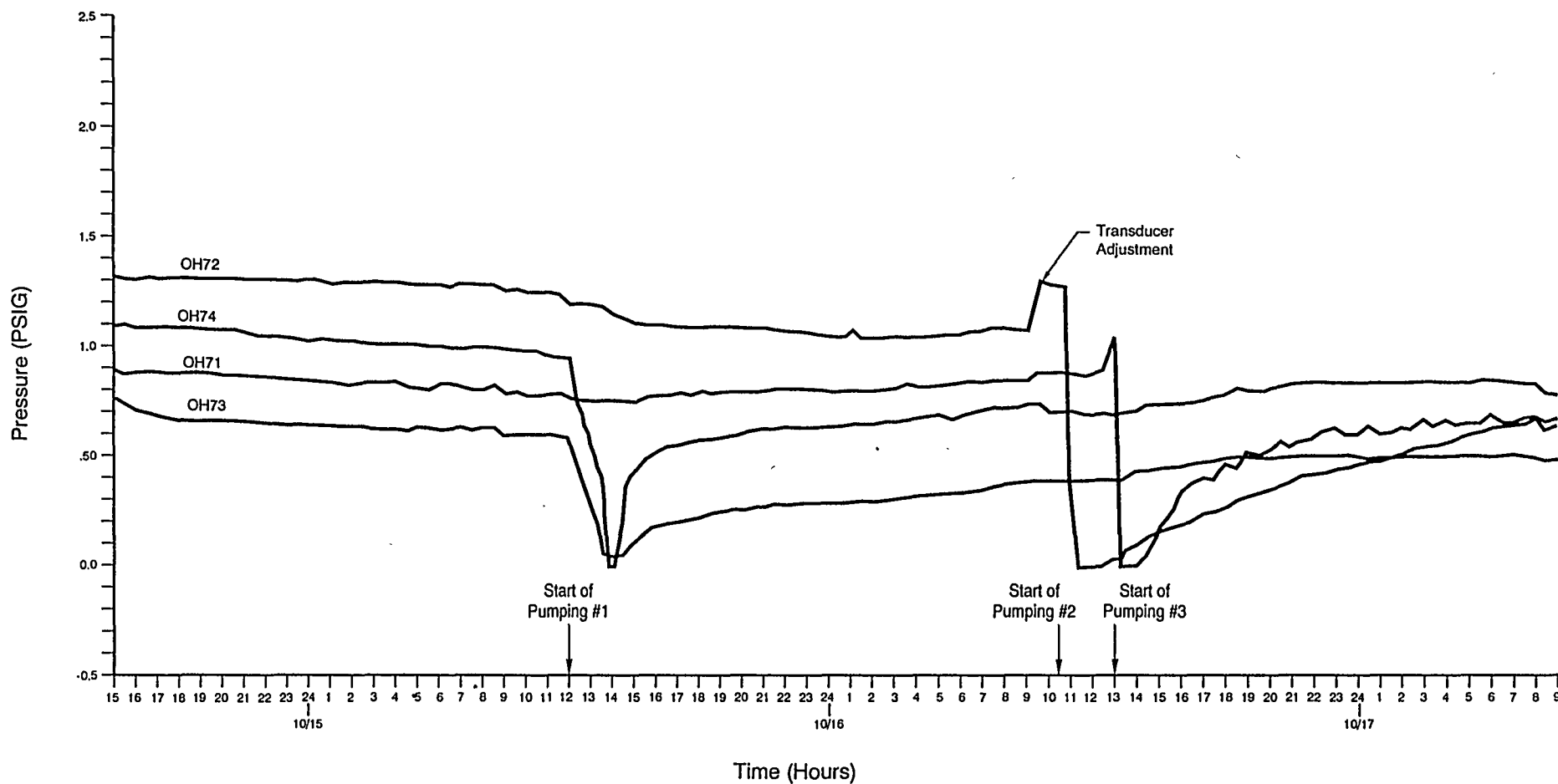

Figure E-5-13
Hydrographs of the E0 Site Testholes OH71, OH72, OH73, and
OH74 Through the End of the Pumping Test, December 1992

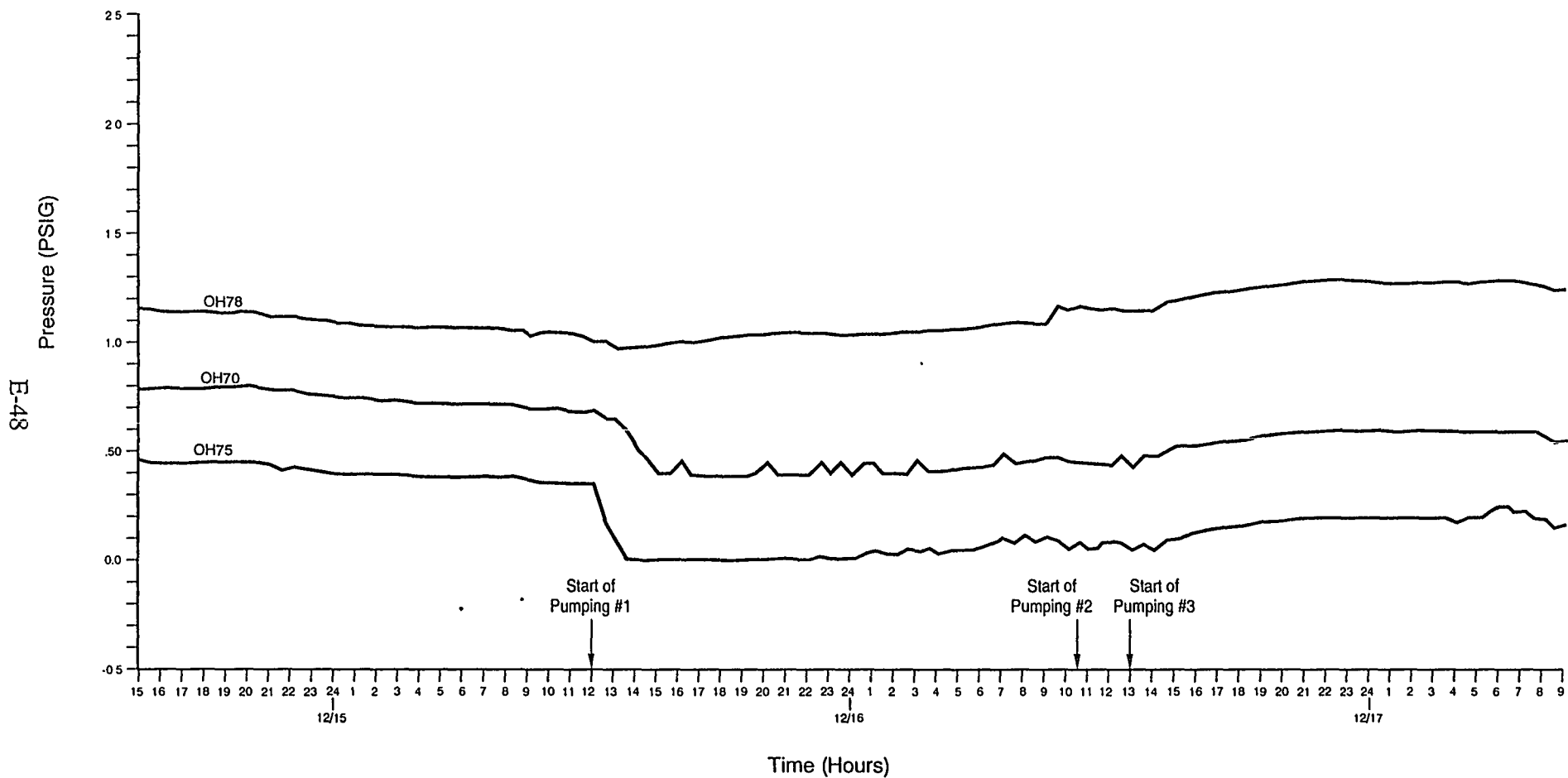

Figure E-5-14
Hydrographs of the E0 Site Testholes OH70, OH75, and
OH78 Through the End of the Pumping Test, December 1992

This test lasted until 1:50 p.m., when the fluid level in the pumped hole OH74 drew down to a level below the pump intake for a total test duration of approximately 1 hour and 50 min. This retest was approximately 1.5 hours shorter in duration than the original test at this site. The shorter pumping duration is the result of having a shorter fluid column in the pumping hole, giving less available drawdown. The short duration of the test and rapid drawdown suggest that reconditioning the holes did little to enhance results from the pumped hole. During this test, fluid levels in all holes were continuously monitored using transducers and the datalogger. In addition, one transducer was set up as a barometer to monitor changes in atmospheric pressure.

After allowing the test area to recover overnight, a second pump test, using hole OH72 as the pumped hole, was attempted on December 16, 1992, at 10:46 a.m. Hole OH74, used for the test the previous day, had not fully recovered by the time the second test started. At the start of the second test, the pumping discharge rate was quickly established at approximately 4.0 gph (15.1 Lph). The fluid level dropped below the pump intake before the next flow rate could be determined. The second pumping event was terminated at 11:14 a.m., after only 28 min of pumping. These results indicate that the surrounding fracture system yielded very little, if any, fluid to the pumped hole. The volume discharged by pumping appears to equal the fluid volume stored in the test hole.

Considering the rapid dewatering of the two previous test holes, the decision was made to perform a third pumping test in a separate test hole. It was anticipated that the staged pumping episodes might yield some additional information about the geometry and interconnection of fracturing at the test site by potentially creating overlapping drawdown responses or different responses in individual test holes.

Prior to initiating the third pumping test, the E0 test site was allowed to recover for approximately 2 hours. Fluid levels in all holes were monitored continuously during this recovery period. The third pumping event, using hole OH71 as the pumped hole, began at 1:00 p.m. on December 16, 1992. Initially, the pumping discharge rate was measured at approximately 6.64 gph (25.1 Lph). The discharge rate was subsequently lowered to less than 5.0 gph (18.9 Lph). However, the hole pumped down to a level below the pump intake before the second flow rate could be accurately determined. The test was stopped 1:16 p.m. Review of the pressure readings in OH71 showed that negative pressure values were

registered after only 9 to 10 min of pumping, indicating that the water level had already dropped below the transducer port by that time.

Recovery of the test area fluid levels was monitored until the following morning, when all data collection was terminated.

E5.3.1 Test Performance and Results

Figure E-5-15 shows the holes that exhibited at least some drawdown response to pumping OH74. The hydrographs in Figures E-5-13 and E-5-14 show that OH70, OH73, and OH75 are the only holes to respond significantly to pumping OH74. In contrast to the initial test performed at this site in October 1992, drawdown response during the December 1992 test was not as widespread and was less pronounced. The decreased response to pumping could be the result of the test area now having fewer interconnected saturated fractures, resulting in a decrease in reservoir size. The smaller saturated area may be the result of fluid removal from the test holes during previous pumping and hole reconditioning. The apparent decreased drawdown may also be the result of the holes not having recovered from previous fluid withdrawal and now having much lower fluid levels prior to this pumping test.

The test holes that showed measurable drawdown did exhibit recovery after pumping ceased in hole OH74. The apparent recovery trends as seen in Figures E-5-13 and E-5-14 suggest that with time, fluid levels may return to their pretest levels. Aquifer test analysis of the drawdown data from pumping OH74 was not performed. The data generated from this pump test are inadequate for performing such analysis with confidence.

Figure E-5-16 shows the test holes that showed some response to the pumping of the second test hole (OH72). Only holes OH73 and OH74 appear to respond to pumping. The apparent response is limited to a slight short-term decrease in fluid pressure or a reduction in the rate of recovery from the OH74 pumping test.

The limited response seen in other holes at the site indicates that OH72 is not hydraulically well connected by fractures to the central part of the test site. This observation is supported by the drawdown responses seen from the previous tests performed at this site. The holes that did show a slight response to pumping are located along the E0 drift centerline and back toward the intersection with the N620 alcove. No response was measured at the holes to the

301681.009.00.000/1/c A35
1/27/95

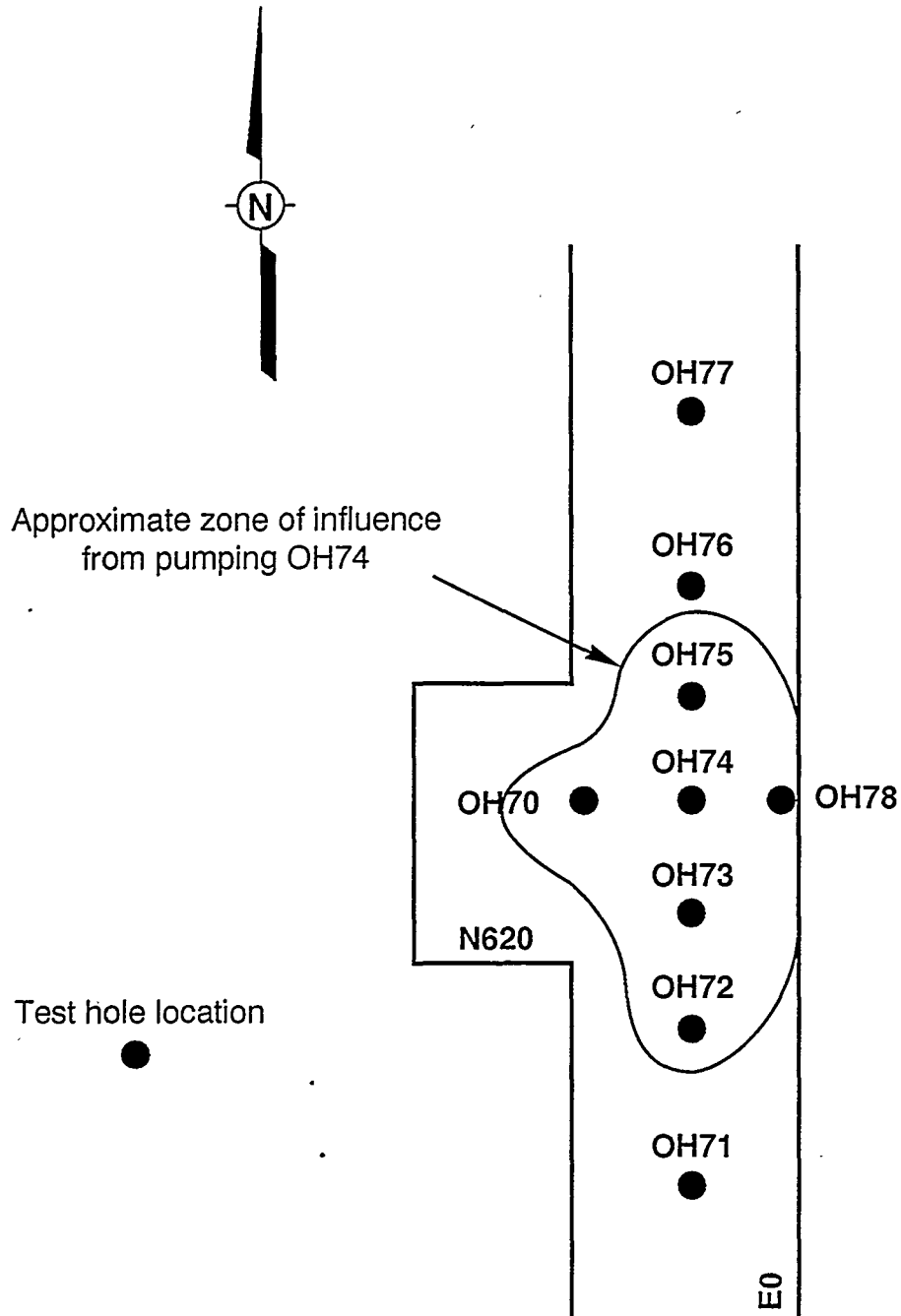

Figure not to scale

Figure E-5-15
Test Holes at the E0 Site Showing Response to Pumping OH74
During the Retest at This Site, December 1992

301681.009.00.000/Id.A36
1/27/95

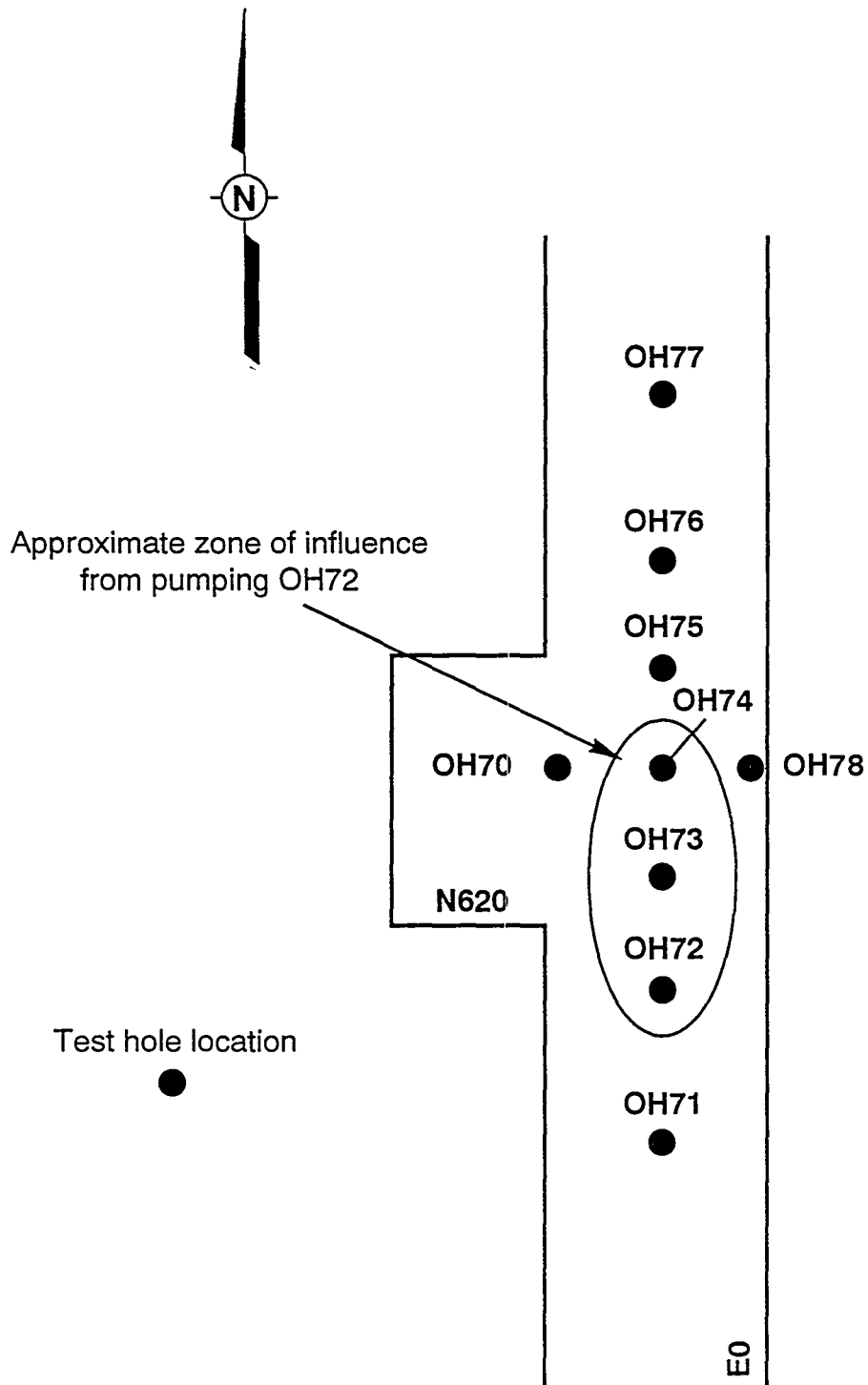

Figure not to scale

Figure E-5-16
Test Holes at the E0 Site Showing Response to Pumping OH72
During the Retest at This Site, December 1992

south of OH72, down the drift, supporting the conclusion that fracturing at this site is somewhat limited to the general area of the intersection. The rapid dewatering of OH72 indicates that the fracture system around this test hole has a very low permeability and that the available fluid reservoir may be very limited in volume.

The hydrologic data generated from pumping OH72 are insufficient for performing an analysis to define hydrologic parameters. Therefore, no analysis other than the evaluation of drawdown and fracture relationships was attempted.

The third and final pumping test at the E0 drift test site was conducted using hole OH71 as the pumping hole. Figure E-5-17 shows the holes at the test site that responded to pumping. No drawdown response was seen in any of the test holes, except OH71, which was the pumped hole. The test results support the conclusion that interconnected fracture systems are absent or at least not significant away from the intersection of the E0 drift and the N620 alcove. Evaluation of the volume of fluid pumped from OH71 suggests that no fluid was donated to the pump hole by the surrounding fractured formation. Therefore, the fracture system in the E0 drift around OH71 is of very low permeability, and the available fluid reservoir is small.

The hydrographs in Figures E-5-13 and E-5-14 show that all other test holes continued to recover from previous pumping activity and were not affected by pumping OH71. Hole OH71 recovered approximately 50 percent of the drawdown achieved during the test by the time that data collection was terminated. Posttest fluid-level monitoring was not long enough to determine whether any of the test holes recovered to their pretest fluid levels.

No drawdown response to pumping OH71 was observed in any of the test holes at the site. Therefore, no pumping test analysis can be performed for this test.

E5.4 Geologic Logging of Cores

As part of the program for hydrologic testing of the fractured part of the DRZ, continuous cores were collected from each of the test holes drilled at the E0 and W170 test sites. These cores were drilled using air to a depth of at least 1 ft beneath the base of MB 139. The cores were logged according to standard procedures established by the WIPP Geotechnical Engineering Section. Of particular importance to this study are the descriptions of fractures

301681 009.00 000/jfd A37
1/27/95

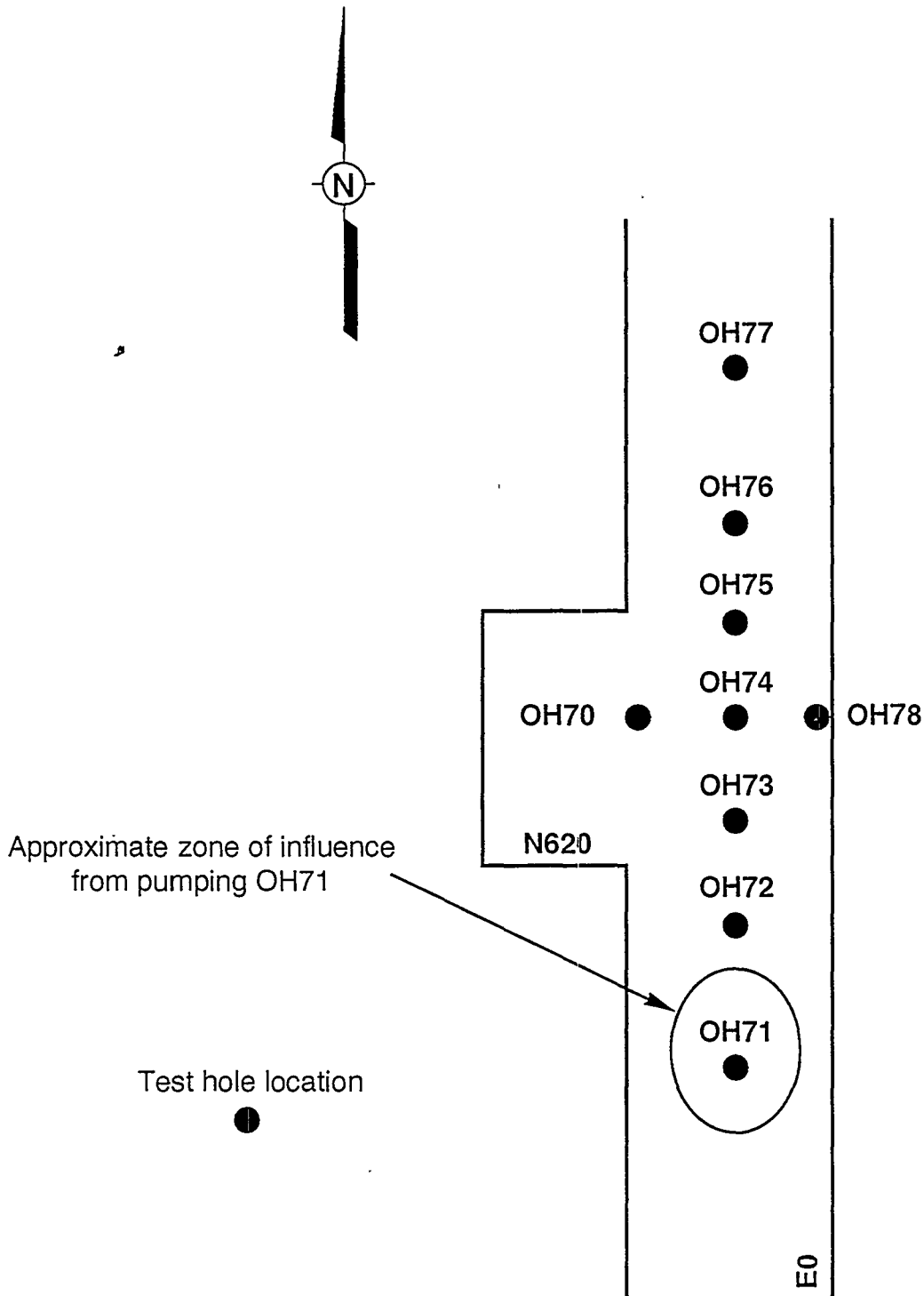

Figure not to scale

Figure E-5-17
Test Holes at the E0 Site Showing Response to Pumping OH71
During the Retest at This Site, December 1992

and separations in the core samples. These core descriptions reveal where the fractured part of the hydrologic system being tested occurs. The data presented in the core logs indicate that, in general, the anhydrite of MB 139 often contains numerous fractures and core breaks, especially in the lower one-half of the bed. The breaks noted in the lower part of the core from MB 139 may signify the presence of fractures in those locations in the subsurface.

Figure E-5-18 presents the core descriptions of holes OH66 and OH74, which were used as pumping holes (and are representative of the conditions) at each of the two test sites.

Figure E-5-18 shows that fractures within the lower portion of MB 139 may be the most prominent fluid transmitting part of the fractured zone beneath the WIPP underground excavations. However, the existence of breaks in the core samples does not necessarily represent open brine-filled fractures in the subsurface.

Hole OH66 was used as the pumping hole during the second pumping test conducted at the W170 test site (Section E5.2). This hole pumped dry quickly, indicating that the local permeability of the fracture system was very low and that the fractures yielded little fluid to the hole during pumping. Therefore, the fractures and breaks observed in the core of OH66 either may not be open in the subsurface or may not be well connected to the overall test area fracture system.

Hole OH74, used as a pumping hole at the E0 test site, also exhibits fractures and breaks in the core sample examined. In this case, the performance of the hole during pumping suggests that the fractures may be better connected to the surrounding area and are possibly more open to transmit fluid during pumping.

E6.0 Summary and Recommendations

The main objective of the Hydrogeologic Testing of the Fractured Part of the Disturbed Rock Zone Beneath the WIPP Excavations Program is to characterize the hydrologic conditions of fracture systems beneath the floor of the repository. Short-duration hydraulic tests were conducted at two underground test sites. These tests were conducted at the intersection of the E0 drift and N620 alcove and in the W170 drift, in front of the underground core library.

301681.009.00.000/ld A38
1/27/95

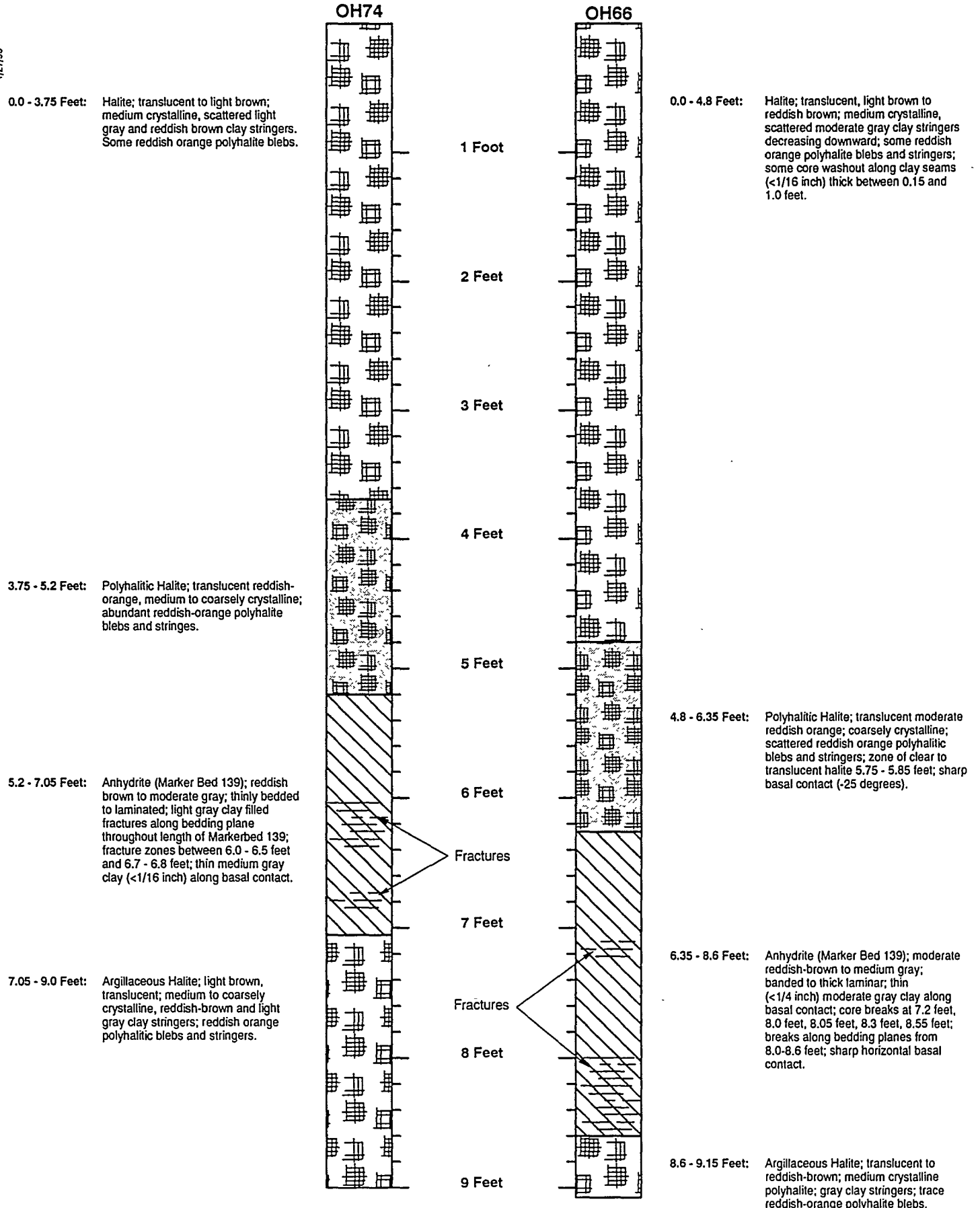

Figure E-5-18
Core Log Description Diagram for Pump Test Holes

These two sites were selected because of their age, their physical characteristics, their relationships to other excavations, the existence of fractures, and their exposures to long periods of water-spreading to control dust and to assist in roadbed consolidation.

Test results indicate that the significant fracture systems that yield water to test holes are restricted to MB 139. For the two sites tested, there appears to be separate, saturated unconnected fracture systems of fairly low transmissivity. At the E0 test site, fracture systems that are connected are confined to the immediate intersection of the drift and alcove. For the W170 site, the intersection did not contain significant connected fractures. Based on the observed drawdown response to pumping, the area within the core library appeared to be underlain by a somewhat more connected fracture system. This condition could be influenced by the width of the individual excavations. The W170 drift, although much older, has a relatively narrow opening in comparison to the core library. These data suggest that excavation dimensions may play a more important role than age in fracture development.

The posttest fluid-level recovery observed at the test sites suggests that the fracture systems beneath these areas are limited, and the available fluid reservoirs are small. Although long-term fluid-level monitoring was not conducted as part of this field program, the data gathered indicate that pumping at these sites was dewatering the fracture systems.

The results of the pumping tests support the concept of limited, bounded fractured fluid reservoirs. Data analysis from the E0 test site showed clear changes in the slope of the plotted drawdown curves for some test holes, indicating the presence of nearby no-flow or low-permeability boundaries. Testing at the W170 site did not produce adequate data for aquifer test analysis.

The Jacob and Theis methods were used to determine transmissivity and storage coefficients for the first test at the E0 site. The calculated transmissivities for all holes were 0.7 to 9.9 ft²/day. Storage coefficients ranged from 0.00038 to 0.0034, indicating that the fracture system at the E0 site is partially confined.

Additional test sites should be developed to define better the nature of fracturing in areas other than the intersections of drifts and rooms. The E0 test site could be expanded to both the north and south of the current site to allow comparative testing. If the test site was

expanded, the results of pump testing away from the drift and alcove intersection could be compared to the results produced by this study, and the effects of excavation geometry could be quantified. Additional testing should be conducted at the lowest possible flow rates for the longest time achievable, and fluid-level recovery should be monitored long term.

The test site located near the AIS in the S90 drift should be prepared for hydrologic testing by providing access to all test holes. This will require moving the electrical substation and other equipment away from the site. This is an important test site, because it was the site of the original fractured zone test in 1988. Fracturing may have become better developed since the initial test was conducted. This site may provide the best location to observe time-dependent development of fracture systems.

E7.0 References

Bechtel National, Inc. (Bechtel), 1986, "Interim Geotechnical Field Data Report," *WIPP-DOE 86-012*, prepared for the U.S. Department of Energy by Bechtel National, Inc., San Francisco, California.

Crawley, M. E., T. W. Cooper, and R. G. Richardson, 1992, "Hydrologic Testing of the Fractured Part of the Disturbed Rock Zone Beneath the WIPP Excavations," report filed by IT Corporation for Westinghouse Electric Corporation, Carlsbad, New Mexico.

Deal, D. E., and J. B. Case, 1987, "Brine Sampling and Evaluation Program, Phase I Report, June, 1987," *DOE-WIPP-87-008*, prepared for the U.S. Department of Energy by IT Corporation and Westinghouse Electric Corporation, Albuquerque, New Mexico.

Deal, D. E., and W. M. Roggenthen, 1991, "Evolution of Hydrologic Systems and Brine Geochemistry in a Deforming Salt Medium: Data from WIPP Brine Seeps," *Proceedings of Waste Management '91*, Tucson, Arizona, Vol. 2, pp. 507-516.

Deal, D. E., R. J. Abitz, D. S. Belski, J. B. Case, M. E. Crawley, R. M. Deshler, P. E. Drez, C. A. Givens, R. B. King, B. A. Lauctes, J. Myers, S. Niou, J. M. Pietz, W. M. Roggenthen, J. R. Tyburski, and M. C. Wallace, 1989, "Brine Sampling and Evaluation Program 1988 Report," *DOE-WIPP-89-015*, Waste Isolation Pilot Plant, U.S. Department of Energy, Carlsbad, New Mexico.

Deal, D. E., R. J. Abitz, D. S. Belski, J. B. Clark, M. E. Crawley, and M. L. Martin, 1991, "Brine Sampling and Evaluation Program, 1989 Report," *DOE-WIPP 91-009*, Waste Isolation Pilot Plant, U.S. Department of Energy, Carlsbad, New Mexico.

Geraghty and Miller, 1989, "AQTESOLV," Aquifer Test Design and Analysis Computer Software, Geraghty and Miller Modeling Group, Reston, Virginia.

Lohman, S. W., 1972, "Ground-Water Hydraulics," U.S. Geological Survey Professional Paper 708, U.S. Government Printing Office, Washington, D.C., 70 pp.

Westinghouse Electric Corporation, 1987, "Geologic Rock Coring Logging," Waste Isolation Pilot Plant Procedure WP 07-502, Carlsbad, New Mexico.

APPENDIX F
NUMERICAL MODELING OF BRINE SEEPAGE FROM
CLAY COMPACTION

THIS PAGE INTENTIONALLY LEFT BLANK

APPENDIX F

F1.0 Introduction

These calculations are order-of-magnitude calculations to approximate how much brine might be released to Waste Isolation Pilot Plant (WIPP) excavations assuming that the only source of brine are saturated clays within thin clay seams in the Salado Formation (Deal and others, 1993; Deal and Bills, 1994). The three analyses consider consolidation of thin compressible clay layers due to the redistribution of stress and generation of excess pore pressure within the clay layers after entry or room excavation. The modeling assumptions are as follows:

- Stress redistribution results in a localized increase in stress that is far more significant in generating excess pore pressure than in near-ground surface consolidation. The stress redistribution deforms the clay, plastically generating an excess pore pressure of several megapascals (MPa) within the disturbed rock zone (DRZ).
- Transient flow to the excavation or boundary dissipates the excess pore pressure within the clay layer.
- The rate of flow depends on the consolidation properties of the clay (hydraulic conductivity, compressibility, and porosity), the cross-sectional area of the clay seams intercepting the excavation, and the extent of the DRZ.
- The tributary method predicts the resulting increasing in the total stress of 3 MPa. Consider that after 1,000 days (Deal and others, 1989, Figure 5-4), the stress abutment zone extends out about 5 excavation diameters. The average diameter for the room is about 3 meters (m).
- The compressibility of the clay is 10^{-7} Pa^{-1} corresponding to a clay of medium compressibility. The hydraulic conductivity of the clay is 10^{-8} centimeters per second (cm/s). Under a change in effective stress of 3 MPa after consolidation is complete, the change in porosity is 30 percent.

F2.0 Room Q

F2.1 Problem Statement

Calculate the amount of brine released to Room Q for two clay seams 3.5 millimeters (mm) thick above and below the orange band (Map Unit 1). The model for consolidation assumes that the increase in stress deforms the clay seams plastically, resulting in 3 MPa of excess pore pressure. Brine flow is induced to the room excavation because of the excess pore pressure. The consolidation of the clay layer is substantial, with a change in porosity of 30 percent.

F2.2 Solution

From Deal and others (1989, p. 5-19), the stress abutment zone extends out about 5 diameters after about 1,000 days. Calculate the size of the abutment for Room Q. The diameter of Room Q is 1.5 m. The length (L) over which flow occurs is:

$$L := 5 \cdot 1.5 \cdot \text{m} \quad L = 750 \cdot \text{cm}$$

From Freeze and Cherry (1979, p. 55), the clay compressibility (α_{clay}) and porosity (ϕ) are:

$$\alpha_{\text{clay}} := 10^{-7} \cdot \text{Pa}^{-1} \quad \phi := 0.50$$

Calculate the change in porosity that results from compression of the clay in the DRZ.

$$\alpha_{\text{clay}} \cdot 3 \cdot 10^6 \cdot \text{Pa} = 0.3$$

The change is substantial and agrees with observation of "squeezing ground."

Calculate the void ratio (e), the conductivity (k), and the coefficient of consolidation (c_v) for the clay. From Freeze and Cherry (1979) and Scott (1963):

$$e := \frac{\phi}{1 - \phi} \quad e = 1$$

$$k := 10^{-8} \cdot \frac{\text{cm}}{\text{sec}}$$

$$\rho_{\text{wo}} := 1.0 \cdot \frac{\text{gm}}{\text{cm}^3}$$

$$c_v := \frac{k \cdot (1 + e)}{\rho_{\text{wo}} \cdot g \cdot \alpha_{\text{clay}}} \quad c_v = 0.002 \cdot \frac{\text{cm}^2}{\text{sec}}$$

where:

- ρ_{wo} = unit weight of water
- g = acceleration constant

Calculate the initial excess pore pressure head (V_0)

$$V_0 := \frac{3 \cdot 10^6 \cdot \text{Pa}}{\rho_{wo} \cdot g} \quad V_0 = 3.059 \cdot 10^4 \text{ cm}$$

We consider the lateral flow to the room over the length of the abutment zone L with zero pressure at the room boundary and a "no flow" boundary condition at the edge of the DRZ. See Scott (1963, p. 184) for explanation of similarities between the thermal case and the consolidation case. We initially define the complementary error function.

From Carslaw and Jaeger (1959, p. 309), the solution for excess pore pressure dissipation is as follows:

$$\text{erfc}(x) := 1 - \text{erf}(x) \quad \kappa := c_v$$

$$v(x,t) := V_0 - V_0 \cdot \left[\sum_{n=0}^{20} (-1)^n \cdot \text{erfc} \left[\frac{(2 \cdot n + 1) \cdot L - x}{2 \cdot \sqrt{\kappa \cdot t}} \right] + \sum_{n=0}^{20} (-1)^n \cdot \text{erfc} \left[\frac{(2 \cdot n + 1) \cdot L + x}{2 \cdot \sqrt{\kappa \cdot t}} \right] \right]$$

where:

V_0 = initial temperature (analogous to initial excess pore pressure)

$v(x,t)$ = temperature as function of space and time (analogous to excess pore pressure over a steady state pore pressure as a function of space and time)

κ = thermal diffusivity (analogous to coefficient of consolidation)

t = time

x = distance ($x = 750$ cm at the Room Q boundary, and $x = 0$ cm at the far field)

$\text{erfc}(x)$ = complimentary error function

$\text{erf}(x)$ = error function, and

n = series index.

With the above properties, plot the distribution of excess pore pressure at several times.

$$x := 0 \cdot L, .01 \cdot L, \dots, L$$

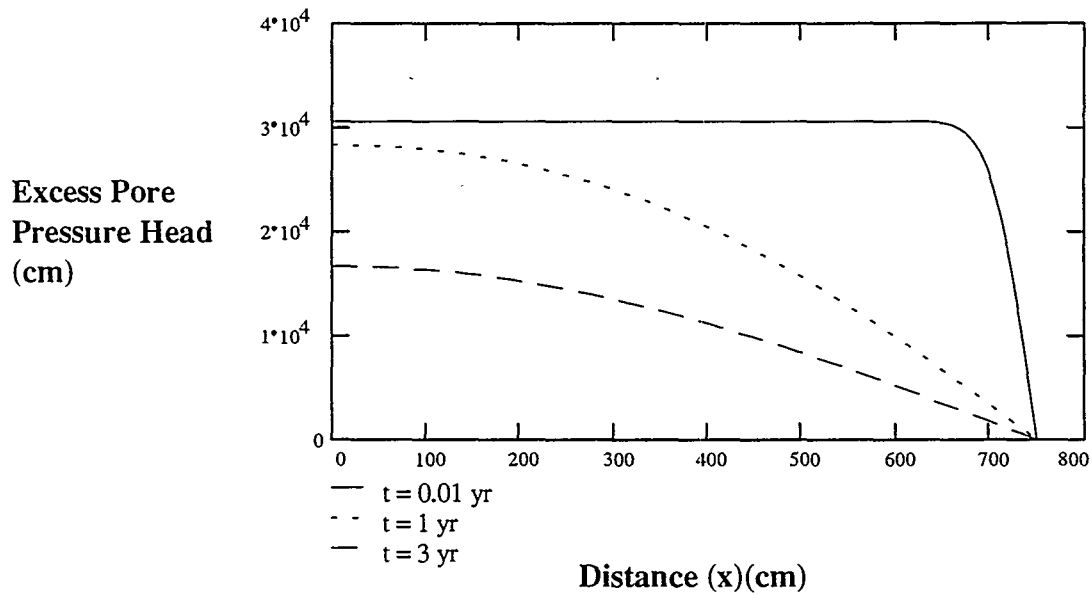

Figure F-2-1
Pore Pressure Distribution Around Room Q

The analysis shows agreement with boundary conditions of the problem. Differentiate the subexpressions with respect to x in the brackets to develop the flux rate.

$$V_0 - V_0 \left[\sum_{n=0}^{20} (-1)^n \cdot \operatorname{erfc} \left[\frac{(2 \cdot n + 1) \cdot L - x}{2 \cdot \sqrt{\kappa \cdot t}} \right] + \sum_{n=0}^{20} (-1)^n \cdot \operatorname{erfc} \left[\frac{(2 \cdot n + 1) \cdot L + x}{2 \cdot \sqrt{\kappa \cdot t}} \right] \right]$$

Differentiate the following subexpressions:

$$\operatorname{erfc} \left[\frac{(2 \cdot n + 1) \cdot L - x}{2 \cdot \sqrt{\kappa \cdot t}} \right] \quad \text{and} \quad \operatorname{erfc} \left[\frac{(2 \cdot n + 1) \cdot L + x}{2 \cdot \sqrt{\kappa \cdot t}} \right]$$

by differentiation with respect to x yields

$$\frac{1}{\sqrt{\pi}} \frac{\exp \left[\frac{-1 \cdot ((2 \cdot n + 1) \cdot L - x)^2}{4 \cdot (\kappa \cdot t)} \right]}{(\sqrt{\kappa \cdot t})} \quad \text{and} \quad \frac{-1}{\sqrt{\pi}} \frac{\exp \left[\frac{-1 \cdot ((2 \cdot n + 1) \cdot L + x)^2}{4 \cdot (\kappa \cdot t)} \right]}{(\sqrt{\kappa \cdot t})}$$

Check the dimensions of the result for correctness.

$$t := 100 \cdot \text{yr} \quad n := 0 \quad x := L$$

$$\frac{1}{\sqrt{\pi}} \cdot \frac{\exp\left[\frac{-1 \cdot ((2 \cdot n + 1) \cdot L - x)^2}{4 \cdot (\kappa \cdot t)}\right]}{(\sqrt{\kappa \cdot t})} = 2.224 \cdot 10^{-4} \cdot \text{cm}^{-1}$$

The dimensions of the subexpression are correct.

Substitute the subexpressions into the sums to calculate the hydraulic gradient.

$$V_0 - V_0 \cdot \left[\sum_{n=0}^{20} (-1)^n \cdot \frac{1}{\sqrt{\pi}} \cdot \frac{\exp\left[\frac{-1 \cdot ((2 \cdot n + 1) \cdot L - x)^2}{4 \cdot (\kappa \cdot t)}\right]}{(\sqrt{\kappa \cdot t})} + \sum_{n=0}^{20} (-1)^n \cdot \frac{-1}{\sqrt{\pi}} \cdot \frac{\exp\left[\frac{-1 \cdot ((2 \cdot n + 1) \cdot L + x)^2}{4 \cdot (\kappa \cdot t)}\right]}{(\sqrt{\kappa \cdot t})} \right]$$

Consider the flux through the cross-sectional area of flow. The flux equals the hydraulic conductivity times the thickness times the length of the clay seam times the number of clay seams. The clay seam sizes are from Table 4-3 of Deal and others (1993). Evaluate the area through which the brine is flowing. There are two clay seams each 3.5 mm thick and 100 m long on each side of the room. Area = 2 * 3.5 mm * 2 * 100 m = 1.4 m². Evaluate the the flux q(t) at the boundary x = L.

x := L

$$q(t) := k \cdot 1 \cdot 1.4 \cdot \text{m}^2 \cdot (V_0 - 1) \cdot \left[\sum_{n=0}^{20} (-1)^n \cdot \frac{1}{\sqrt{\pi}} \cdot \frac{\exp\left[\frac{-1 \cdot ((2 \cdot n + 1) \cdot L - x)^2}{4 \cdot (\kappa \cdot t)}\right]}{(\sqrt{\kappa \cdot t})} \dots \right. \\ \left. + \sum_{n=0}^{20} (-1)^n \cdot \frac{-1}{\sqrt{\pi}} \cdot \frac{\exp\left[\frac{-1 \cdot ((2 \cdot n + 1) \cdot L + x)^2}{4 \cdot (\kappa \cdot t)}\right]}{(\sqrt{\kappa \cdot t})} \right]$$

Check the result with an approximate relation for the derivative after one year.

$$q(1 \cdot \text{yr}) = 823 \cdot \frac{\text{cm}^3}{\text{day}} \quad k \cdot 1 \cdot 1.4 \cdot \text{m}^2 \cdot \frac{v(L, 1 \cdot \text{yr}) - v(.999 \cdot L, 1 \cdot \text{yr})}{.001 \cdot L} = 823 \cdot \frac{\text{cm}^3}{\text{day}}$$

The results are in agreement. The inflow rate after 10 years and after 20 years will be as follows:

$$q(10\text{-yr}) = 59 \cdot \frac{\text{cm}^3}{\text{day}} \quad \text{and} \quad q(20\text{-yr}) = 3.5 \cdot \frac{\text{cm}^3}{\text{day}}$$

Plot the inflow rate as a function of time over the period from 800 days to 25 years. See Howarth and others (1994) for measurement time period.

$t := 800\text{-day}, 1000\text{-day}.. 10000\text{-day}$

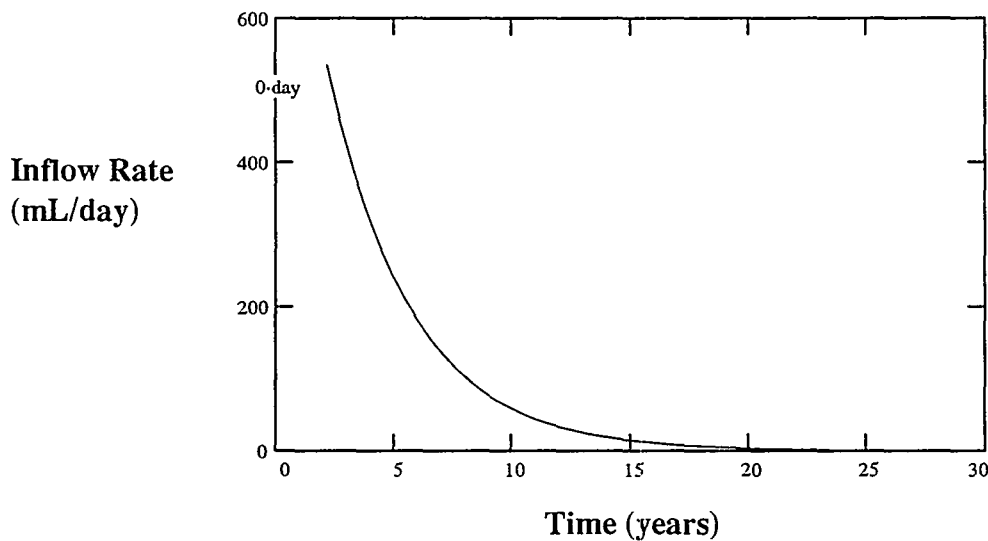

Figure F-2-2
Brine Inflow into Room Q

Determine the cumulative flow over time by integration of the flow rate relation with time. Integrate each subexpression separately, and combine in the sums.

$$\left[\frac{1}{\sqrt{\pi}} \frac{\exp\left[\frac{-1 \cdot ((2 \cdot n + 1) \cdot L - x)^2}{4 \cdot (\kappa \cdot t)}\right]}{(\sqrt{\kappa \cdot \sqrt{t}})} \right]$$

by integration, yields

$$\left[\frac{2 \cdot \sqrt{t} \cdot \exp\left[\frac{-1 \cdot (-2 \cdot L \cdot n - L + x)^2}{4 \cdot (t \cdot \kappa)}\right]}{(\sqrt{\pi \cdot \sqrt{\kappa}})} + \frac{(-2 \cdot L \cdot n - L + x) \cdot \sqrt{\pi} \cdot \operatorname{erf}\left[\frac{1 \cdot (-2 \cdot L \cdot n - L + x)}{2 \cdot (\sqrt{\kappa \cdot \sqrt{t}})}\right]}{(\sqrt{\pi \cdot \sqrt{\kappa}})} \right]$$

and the following term:

$$\left[\frac{-1}{\sqrt{\pi}} \cdot \frac{\exp\left[\frac{-1 \cdot ((2 \cdot n + 1) \cdot L + x)^2}{4 \cdot (\kappa \cdot t)}\right]}{(\sqrt{\kappa \cdot t})} \right]$$

by integration, yields

$$\frac{- \left[2 \cdot \sqrt{t} \cdot \exp\left[\frac{-1 \cdot (2 \cdot L \cdot n + L + x)^2}{4 \cdot (t \cdot \kappa)}\right] + \frac{(2 \cdot L \cdot n + L + x)}{\sqrt{\kappa}} \cdot \sqrt{\pi} \cdot \operatorname{erf}\left[\frac{1 \cdot (2 \cdot L \cdot n + L + x)}{2 \cdot (\sqrt{\kappa \cdot t})}\right] \right]}{(\sqrt{\pi \cdot \kappa})}$$

Substituting the subexpressions into a subexpression ($\Theta(t)$) and calculating the cumulative flow rate ($Q(t)$):

$$\Theta(t) := \left[\sum_{n=0}^{20} (-1)^n \cdot \left[\frac{2 \cdot \sqrt{t} \cdot \exp\left[\frac{-1 \cdot (-2 \cdot L \cdot n - L + x)^2}{4 \cdot (t \cdot \kappa)}\right] + \frac{(-2 \cdot L \cdot n - L + x)}{\sqrt{\kappa}} \cdot \sqrt{\pi} \cdot \operatorname{erf}\left[\frac{1 \cdot (-2 \cdot L \cdot n - L + x)}{2 \cdot (\sqrt{\kappa \cdot t})}\right]}{(\sqrt{\pi \cdot \kappa})} \right] \dots \cdot 1 \right. \\ \left. + \sum_{n=0}^{20} (-1)^n \cdot \left[\frac{- \left[2 \cdot \sqrt{t} \cdot \exp\left[\frac{-1 \cdot (2 \cdot L \cdot n + L + x)^2}{4 \cdot (t \cdot \kappa)}\right] + \frac{(2 \cdot L \cdot n + L + x)}{\sqrt{\kappa}} \cdot \sqrt{\pi} \cdot \operatorname{erf}\left[\frac{1 \cdot (2 \cdot L \cdot n + L + x)}{2 \cdot (\sqrt{\kappa \cdot t})}\right] \right]}{(\sqrt{\pi \cdot \kappa})} \right] \right]$$

and

$$Q(t) := \Theta(t) \cdot \left(k \cdot 1.4 \cdot m^2 \cdot \frac{V_0}{cm} \cdot sec \right)$$

Check the analysis against direct numerical integration:

$$Q(1600 \cdot \text{day}) - Q(800 \cdot \text{day}) = 317.777 \cdot cm^{-1} \cdot sec \cdot \text{liter}$$

TOL := 1.0 (TOL is calculation tolerance)

$$\int_{800 \cdot \text{day}}^{1600 \cdot \text{day}} q(t) dt = 317.777 \cdot \text{liter}$$

The results of the closed-form solution agree with the numerical analysis.
Plot the cumulative flow with time.

t := 800·day, 900·day .. 1600·day

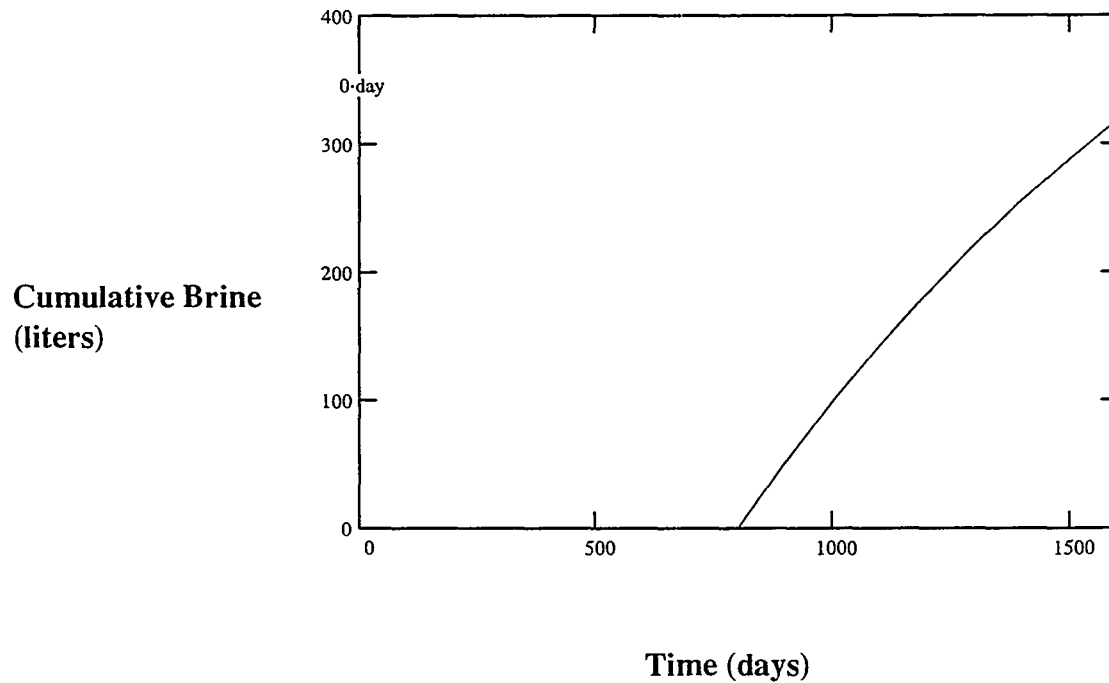

Figure F-2-3
Cumulative Flow into Room Q

F2.3 Conclusions

The results agree approximately with the measured flow into Room Q (see Howarth and others, 1994).

F3.0 Standard WIPP Waste Storage Room

F3.1 Problem Statement

Calculate the amount of brine released to a Waste Disposal Room, from two clay seams totaling 17.1 mm thick above and below the orange band (Map Unit 1). The model for consolidation assumes that the increase in stress deforms the clay seams plastically resulting in 3 MPa of excess pore pressure. Brine flow is induced to the room excavation due to the excess pore pressure. The consolidation of the clay layer is substantial with a change in porosity of 30 percent.

F3.2 Solution

From Deal and others (1989, p. 5-19), the stress abutment zone extends out about 5 diameters after about 1,000 days. Calculate the size of the abutment for the Waste Storage Room. The diameter of a Waste Disposal Room is 3.56 m (see Deal and others, 1993, p. 2-2). The length (L) over which flow occurs is:

$$L := 5 \cdot 3.56 \cdot \text{m} \quad L = 17.8 \cdot \text{m}$$

From Freeze and Cherry (1979, p. 55), the clay compressibility (α_{clay}) and porosity (ϕ) are:

$$\alpha_{\text{clay}} := 10^{-7} \cdot \text{Pa}^{-1} \quad \phi := 0.50$$

Calculate the change in porosity due to compression of the clay in the DRZ.

$$\alpha_{\text{clay}} \cdot 3 \cdot 10^6 \cdot \text{Pa} = 0.3$$

The change is substantial and agrees with observation of "squeezing ground."

Calculate the void ratio (e), the conductivity (k), and the coefficient of consolidation (c_v) for the clay (from Scott, 1963 and Freeze and Cherry, 1979):

$$e := \frac{\phi}{1 - \phi} \quad e = 1$$

$$k := 10^{-8} \cdot \frac{\text{cm}}{\text{sec}}$$

$$\rho_{\text{wo}} := 1.0 \cdot \frac{\text{gm}}{\text{cm}^3}$$

$$c_v := \frac{k \cdot (1 + e)}{\rho_{\text{wo}} \cdot g \cdot \alpha_{\text{clay}}} \quad c_v = 0.002 \cdot \frac{\text{cm}^2}{\text{sec}}$$

Calculate the initial pore pressure head (V_0)

$$V_0 := \frac{3 \cdot 10^6 \cdot \text{Pa}}{\rho_{w0} \cdot g} \quad V_0 = 3.059 \cdot 10^4 \cdot \text{cm}$$

We consider the lateral flow to the room over the length of the abutment zone L with zero pressure at the room boundary and a "no flow" boundary condition at the edge of the DRZ. See Scott (1963, p.184) for more details in the similarities between the thermal case and the consolidation case.

From Carslaw and Jaeger (1959, p. 309), the solution for excess pore pressure dissipation is as follows:

$$\text{erfc}(x) := 1 - \text{erf}(x) \quad \kappa := c_v$$

$$v(x,t) := V_0 - V_0 \cdot \left[\sum_{n=0}^{20} (-1)^n \cdot \text{erfc} \left[\frac{(2 \cdot n + 1) \cdot L - x}{2 \cdot \sqrt{\kappa \cdot t}} \right] + \sum_{n=0}^{20} (-1)^n \cdot \text{erfc} \left[\frac{(2 \cdot n + 1) \cdot L + x}{2 \cdot \sqrt{\kappa \cdot t}} \right] \right]$$

where:

V_0 = initial temperature (analogous to initial excess pore pressure)

$v(x,t)$ = temperature as function of space and time (analogous to excess pore pressure over a steady state pore pressure as a function of space and time)

κ = thermal diffusivity (analogous to coefficient of consolidation)

t = time

x = distance

$\text{erfc}(x)$ = complimentary error function

$\text{erf}(x)$ = error function, and

n = series index

With the above properties, plot the distribution of pore pressure at several times.

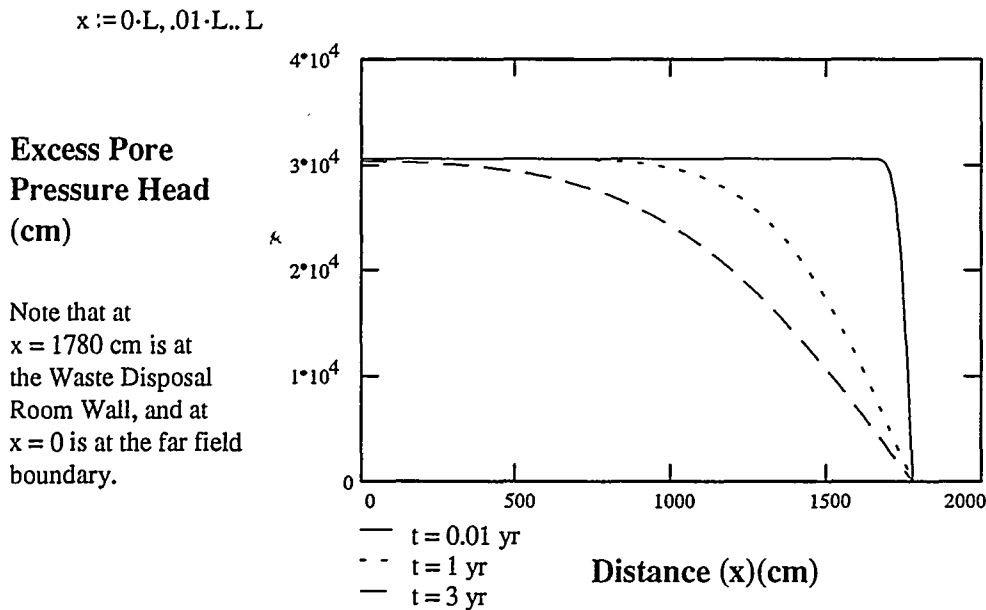

Figure F-3-1
Pore Pressure Distribution Around Standard WIPP Waste Disposal Room

The analysis shows agreement with boundary conditions of the problem. From the former equation:

$$V_0 - V_0 \left[\sum_{n=0}^{20} (-1)^n \cdot \operatorname{erfc} \left[\frac{(2 \cdot n + 1) \cdot L - x}{2 \cdot \sqrt{\kappa \cdot t}} \right] + \sum_{n=0}^{20} (-1)^n \cdot \operatorname{erfc} \left[\frac{(2 \cdot n + 1) \cdot L + x}{2 \cdot \sqrt{\kappa \cdot t}} \right] \right]$$

Differentiate the following subexpressions from the former equation to develop the flux.

$$\operatorname{erfc} \left[\frac{(2 \cdot n + 1) \cdot L - x}{2 \cdot \sqrt{\kappa \cdot t}} \right] \qquad \operatorname{erfc} \left[\frac{(2 \cdot n + 1) \cdot L + x}{2 \cdot \sqrt{\kappa \cdot t}} \right]$$

by differentiation with respect to x yields

$$\frac{1}{\sqrt{\pi}} \frac{\exp \left[\frac{-1 \cdot ((2 \cdot n + 1) \cdot L - x)^2}{4 \cdot (\kappa \cdot t)} \right]}{(\sqrt{\kappa \cdot t})} \qquad \frac{-1}{\sqrt{\pi}} \frac{\exp \left[\frac{-1 \cdot ((2 \cdot n + 1) \cdot L + x)^2}{4 \cdot (\kappa \cdot t)} \right]}{(\sqrt{\kappa \cdot t})}$$

Check the dimensions of the result for correctness.

$$t := 100 \cdot \text{yr} \quad n := 0 \quad x := L \quad x = 17.8 \cdot \text{m}$$

$$\frac{1}{\sqrt{\pi}} \frac{\exp\left[\frac{-1 \cdot ((2 \cdot n + 1) \cdot L - x)^2}{4 \cdot (\kappa \cdot t)}\right]}{(\sqrt{\kappa \cdot t})} = 2.224 \cdot 10^{-4} \cdot \text{cm}^{-1}$$

The dimensions of the subexpression are correct.

Substitute the subexpressions into the sums to calculate the hydraulic gradient.

$$V_0 - V_0 \cdot \left[\sum_{n=0}^{20} (-1)^n \cdot \left[\frac{1}{\sqrt{\pi}} \frac{\exp\left[\frac{-1 \cdot ((2 \cdot n + 1) \cdot L - x)^2}{4 \cdot (\kappa \cdot t)}\right]}{(\sqrt{\kappa \cdot t})} \right] + \sum_{n=0}^{20} (-1)^n \cdot \left[\frac{-1}{\sqrt{\pi}} \frac{\exp\left[\frac{-1 \cdot ((2 \cdot n + 1) \cdot L + x)^2}{4 \cdot (\kappa \cdot t)}\right]}{(\sqrt{\kappa \cdot t})} \right] \right]$$

Consider the flux through the cross-sectional area of flow. The flux $q(t)$ equals the hydraulic conductivity times the thickness times the length of the clay seam times the number of clay seams. The clay seam sizes of $(3.5 + 3.5 + 10.1) = 17.1$ mm for the clay seams are from Table 4-3 of Deal and others (1993). The length of the room is 91.4 m from Case et al., (1991, p. 2-4). Note that we multiply by 2 to account for both sides of the room. Evaluate the flux at the boundary $x = L$:

$$x := L$$

$$q(t) := k \cdot 1 \cdot 2 \cdot 17.1 \cdot \text{mm} \cdot 91.4 \cdot \text{m} \cdot (V_0 - 1) \cdot \left[\sum_{n=0}^{20} (-1)^n \cdot \left[\frac{1}{\sqrt{\pi}} \frac{\exp\left[\frac{-1 \cdot ((2 \cdot n + 1) \cdot L - x)^2}{4 \cdot (\kappa \cdot t)}\right]}{(\sqrt{\kappa \cdot t})} \right] + \sum_{n=0}^{20} (-1)^n \cdot \left[\frac{-1}{\sqrt{\pi}} \frac{\exp\left[\frac{-1 \cdot ((2 \cdot n + 1) \cdot L + x)^2}{4 \cdot (\kappa \cdot t)}\right]}{(\sqrt{\kappa \cdot t})} \right] \right]$$

Check the result with an approximate relation for the derivative after one year.

$$q(1 \cdot \text{yr}) = 1.837 \cdot 10^3 \frac{\text{cm}^3}{\text{day}}$$

$$k \cdot 1 \cdot 2 \cdot 17.1 \cdot \text{mm} \cdot 91.4 \cdot \text{m} \cdot \frac{v(L, 1 \cdot \text{yr}) - v(.999 \cdot L, 1 \cdot \text{yr})}{.001 \cdot L} = 1.837 \cdot 10^3 \frac{\text{cm}^3}{\text{day}}$$

The results are in agreement. The inflow rates after 10 and 20 years will be:

$$q(10\text{-yr}) = 573 \cdot \frac{\text{cm}^3}{\text{day}} \quad , \quad q(20\text{-yr}) = 341 \cdot \frac{\text{cm}^3}{\text{day}}$$

Plot the inflow rate as a function of time over the period from 0 to 200 years.

t := 1·yr, 2·yr.. 200·yr

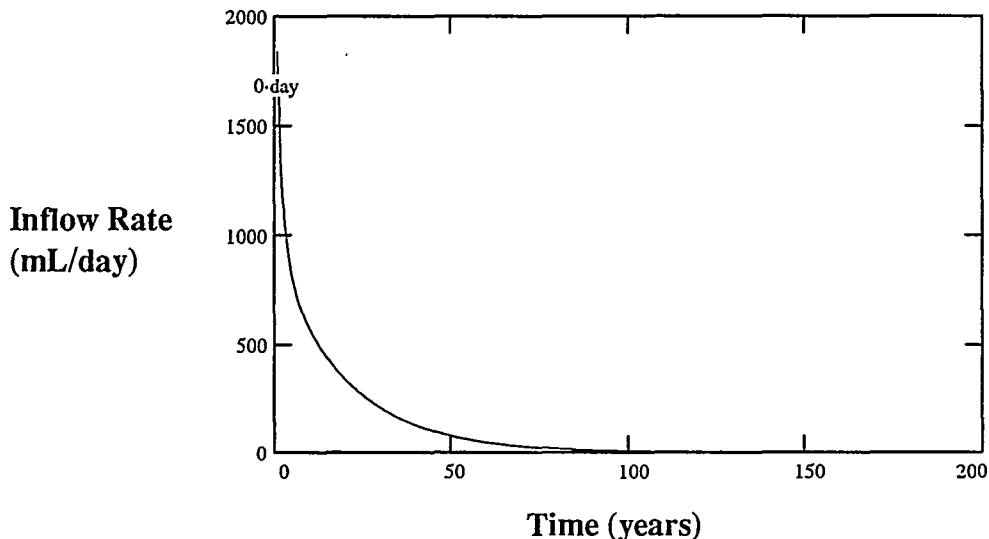

Figure F-3-2
Brine Inflow into a Waste Disposal Room

Determine the cumulative flow over time by integration of the flow rate relation with time. Integrate each subexpression separately and combine in the sums.

$$\left[\frac{1}{\sqrt{\pi}} \cdot \frac{\exp\left[\frac{-1 \cdot ((2 \cdot n + 1) \cdot L - x)^2}{4 \cdot (\kappa \cdot t)}\right]}{(\sqrt{\kappa \cdot t})} \right]$$

by integration, yields

$$\frac{\left[2 \cdot \sqrt{t} \cdot \exp\left[\frac{-1 \cdot (-2 \cdot L \cdot n - L + x)^2}{4 \cdot (t \cdot \kappa)}\right] + \frac{(-2 \cdot L \cdot n - L + x)}{\sqrt{\kappa}} \cdot \sqrt{\pi} \cdot \operatorname{erf}\left[\frac{1 \cdot (-2 \cdot L \cdot n - L + x)}{2 \cdot (\sqrt{\kappa \cdot t})}\right] \right]}{(\sqrt{\pi \cdot \kappa})}$$

similarly,

$$\left[\frac{-1}{\sqrt{\pi}} \frac{\exp\left[\frac{-1}{4} \frac{((2 \cdot n + 1) \cdot L + x)^2}{(\kappa \cdot t)}\right]}{(\sqrt{\kappa \cdot \sqrt{t}})} \right]$$

by integration, yields

$$\frac{-\left[2 \cdot \sqrt{t} \cdot \exp\left[\frac{-1}{4} \frac{(2 \cdot L \cdot n + L + x)^2}{(t \cdot \kappa)}\right] + \frac{(2 \cdot L \cdot n + L + x)}{\sqrt{\kappa}} \cdot \sqrt{\pi} \cdot \operatorname{erf}\left[\frac{1}{2} \frac{(2 \cdot L \cdot n + L + x)}{(\sqrt{\kappa \cdot \sqrt{t}})}\right] \right]}{(\sqrt{\pi \cdot \sqrt{\kappa}})}$$

Substituting the subexpressions into to subexpressions $\Theta(t)$, and calculating the cumulative flow rate $Q(t)$:

$$\Theta(t) := \left[\sum_{n=0}^{20} (-1)^n \cdot \left[\frac{\left[2 \cdot \sqrt{t} \cdot \exp\left[\frac{-1}{4} \frac{(-2 \cdot L \cdot n - L + x)^2}{(t \cdot \kappa)}\right] + \frac{(-2 \cdot L \cdot n - L + x)}{\sqrt{\kappa}} \cdot \sqrt{\pi} \cdot \operatorname{erf}\left[\frac{1}{2} \frac{(-2 \cdot L \cdot n - L + x)}{(\sqrt{\kappa \cdot \sqrt{t}})}\right] \right]}{(\sqrt{\pi \cdot \sqrt{\kappa}})} \right] \right] \dots \cdot 1$$

$$+ \sum_{n=0}^{20} (-1)^n \cdot \left[\frac{\left[-2 \cdot \sqrt{t} \cdot \exp\left[\frac{-1}{4} \frac{(2 \cdot L \cdot n + L + x)^2}{(t \cdot \kappa)}\right] + \frac{(2 \cdot L \cdot n + L + x)}{\sqrt{\kappa}} \cdot \sqrt{\pi} \cdot \operatorname{erf}\left[\frac{1}{2} \frac{(2 \cdot L \cdot n + L + x)}{(\sqrt{\kappa \cdot \sqrt{t}})}\right] \right]}{(\sqrt{\pi \cdot \sqrt{\kappa}})} \right] \right]$$

and

$$Q(t) := \Theta(t) \cdot \left(\kappa \cdot 2 \cdot 17.1 \cdot \text{mm} \cdot 91.43 \cdot \text{m} \cdot \frac{\text{V}_0}{\text{cm}} \cdot \text{sec} \right)$$

Check the analysis against direct numerical integration:

TOL := 0.05 TOL is calculation tolerance

$$Q(200 \cdot \text{yr}) - Q(0.1 \cdot \text{yr}) = 7.924 \cdot 10^3 \cdot \text{cm}^{-1} \cdot \text{sec} \cdot \text{liter}$$

$$\int_{0.1 \cdot \text{yr}}^{200 \cdot \text{yr}} q(t) dt = 7.946 \cdot 10^3 \cdot \text{liter}$$

The results of the closed form solution agree with the numerical analysis

Plot the cumulative brine with time.

$t := .1\text{-yr}, 2.1\text{-yr}.. 200\text{-yr}$

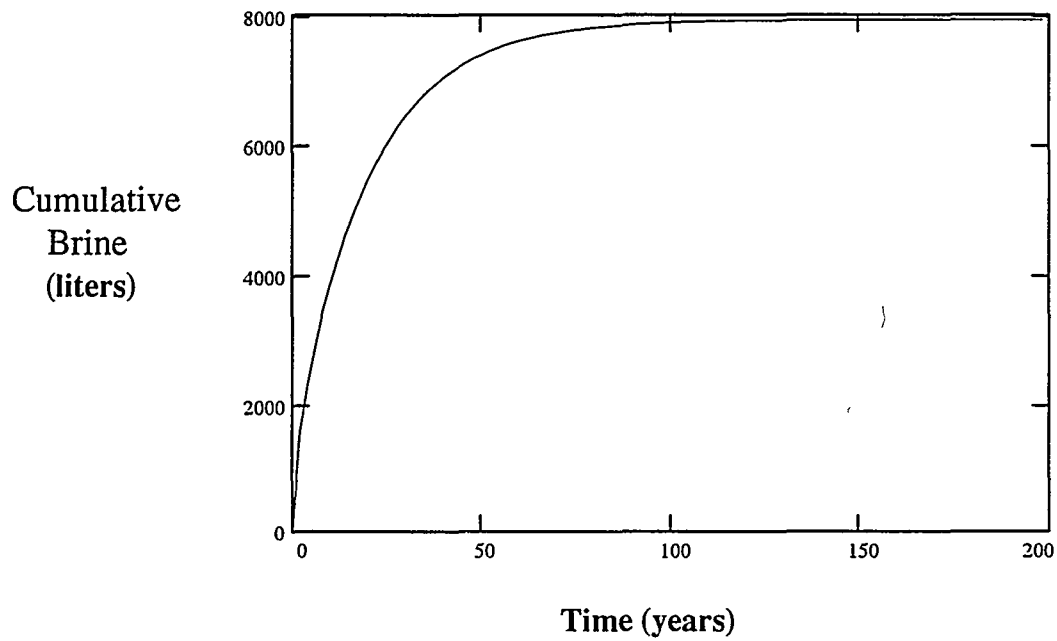

Figure F-3-3
Cumulative Flow into a Waste Disposal Room

F3.3 Conclusion

The amount of brine entering a waste disposal room is 8,000 L after about 100 years.

F4.0 Axial Consolidation Around a Borehole

F4.1 Problem Statement

Calculate the amount of brine released to a vertical borehole intercepting a clay layer that is undergoing consolidation. Consider that the borehole is in the floor of Room G and intercepts a 1-cm-thick clay layer 10 m below the floor.

F4.2 Solution

From Scott (1963, p. 203), the average degree of consolidation, $U(T_r, m)$ is given by:

$$U(T_r, m) := 1 - e^{-2 \frac{T_r}{m}}$$

$$m = \left(\frac{n^2}{n^2 - 1} \cdot \ln(n) - \frac{3 \cdot n^2 - 1}{4 \cdot n^2} + \frac{k_r}{r_w \cdot K} \cdot \frac{n^2 - 1}{n^2} \right)$$

$$T_r = c_r \cdot \frac{t}{r_e^2}$$

$$n = \frac{r_e}{r_w}$$

where:

- t = time,
- T_r = dimensionless time,
- K = constant related to the surface resistance,
- k_r = hydraulic conductivity,
- r_e = effective radius of drainage,
- r_w = radius of the borehole
- c_r = coefficient of consolidation
- m = dimensionless coefficient, and
- n = dimensionless coefficient for radius.

Construct a plot of the degree of consolidation with the dimensionless time.

$$T_r := 0.01, 0.02..5$$

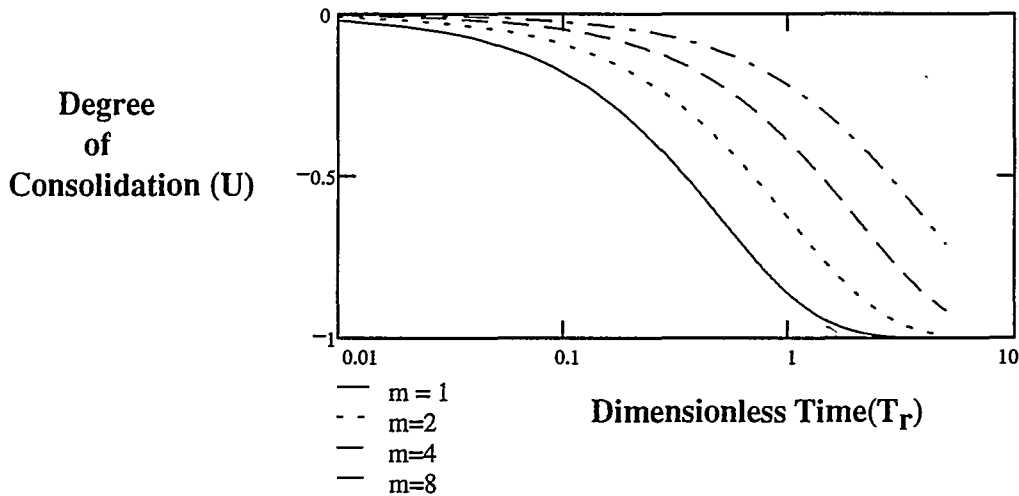

Figure F-4-1
Degree of Consolidation with the Dimensionless Time

The results agree with the results in Scott (1963, p. 202).

From Freeze and Cherry (1979, p. 55), the clay compressibility α_{clay} is as follows:

$$\alpha_{clay} := 10^{-7} \cdot Pa^{-1}$$

Note that initially the excavation compresses the sidewalls, with a resulting increase in stress that could be predicted by the tributary method. Consider that after 1,000 days from Deal and others (1989, p. 5-19), the stress abutment zone extends out about 5 excavation diameters. The average diameter for the room is:

$$\sqrt{\frac{33 \cdot ft \cdot 13}{\pi}} \cdot ft = 3.562 \cdot m$$

At this time the stress abutment zone extends out 17.8 m as given in the VISCOT analysis in Deal and others (1989), the increase in stress in MPa is

$$\frac{3.562}{17.8} \cdot 15 = 3.002$$

These calculations suggest that the increase in stress is of the order of 3 to 5 MPa. Calculate the cumulative amount of brine that would flow to the borehole due to an average increase in stress of 3 MPa.

$$\alpha_{\text{clay}} \cdot 3 \cdot 10^6 \cdot \text{Pa} = 0.3$$

$$\Delta\phi := 0.3$$

$$t := 1 \cdot \text{cm}$$

$$A_{\text{clay}} := \pi \cdot (17.8 \cdot \text{m})^2 \quad A_{\text{clay}} = 9.954 \cdot 10^6 \cdot (\text{cm}^2)$$

$$\text{Volume} := \frac{t \cdot A_{\text{clay}} \cdot \Delta\phi}{1} \quad \text{Volume} = 2.986 \cdot 10^3 \cdot \text{liter} \quad \text{Volume} := 340.234$$

Where:

- t = thickness of the clay seam
- A = area affected by a change in stress
- Volume = volume of brine stored in the clay
- $\Delta\phi$ = change in porosity of seam

Consider the properties of the borehole, and the clay. From Deal and others (1989, Table A-1), the diameter of the hole (a) is

$$a := 3.5 \cdot \text{in} \quad a = 8.89 \cdot \text{cm}$$

From Freeze and Cherry (1979, p. 37), the porosity (ϕ) of clays range from 40 to 70 percent. Use

$$\phi := 0.5$$

The void ratio (e) is:

$$e := \frac{\phi}{1 - \phi} \quad e = 1$$

From Freeze and Cherry (1979, p. 29), the hydraulic conductivity of clays (k_r) ranges from 10^{-6} to 10^{-8} cm/sec. Use

$$k_r := 10^{-8} \frac{\text{cm}}{\text{sec}} \quad \gamma_{\text{wo}} := 62.4 \frac{\text{lb}_f}{\text{ft}^3} \quad g = 980.665 \frac{\text{cm}}{\text{sec}^2} \quad \frac{\gamma_{\text{wo}}}{g} = 1 \frac{\text{gm}}{\text{cm}^3}$$

Calculate the coefficient of consolidation. From Scott (1963, p. 184) , the coefficient of consolidation is

$$c_r := k_r \cdot \frac{1 + e}{\gamma_{wo} \cdot \alpha_{clay}} \quad c_r = 0.002 \cdot \frac{\text{cm}^2}{\text{sec}}$$

Consider the effective radius of drainage (r_e) equal to the far-field distance from the center of the borehole (Deal and others, 1989, p. 5-19).

$$r_e := 20 \cdot \text{m}$$

and the diameter of the borehole equal to:

$$r_w := a \quad r_w = 0.089 \cdot \text{m}$$

Calculate the dimensionless coefficients. Consider a range for the ratio

$$n := \frac{r_e}{r_w} \quad n = 224.972$$

$$T_r = c_r \cdot \frac{t_r}{r_e^2} \quad \frac{r_e^2}{c_r} = 62.124 \cdot \text{yr}$$

$$\mu(\text{Ratio}) := \frac{n^2}{n^2 - 1} \cdot \ln(n) - \frac{3 \cdot n^2 - 1}{4 \cdot n^2} + (\text{Ratio}) \cdot \frac{n^2 - 1}{n^2}$$

where:

$$\mu(\text{Ratio}) = \text{function of the ratio} \quad \frac{k_r}{r_w \cdot K}$$

k_r = the permeability of the undisturbed clay

$1/K$ = surface resistance

T_r = dimensionless time factor

t_r = time

m is not sensitive to the ratio. Use 0.2 for a middle range m value

$$\text{Ratio} := .2$$

$$m := \mu(\text{Ratio}) \quad m = 4.866$$

Determine the cumulative amount of brine flowing to the borehole.

$$T_r := 0.01, 0.02.. 1.3$$

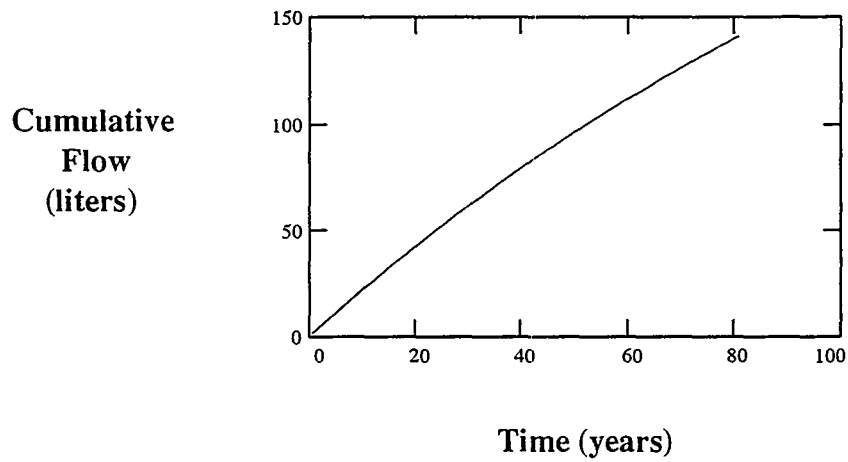

Figure F-4-2
Cumulative Inflow to a Borehole

Consider the flow rate as a function of time.

$$U_d(t, m) := \frac{2}{m} \cdot \exp\left[-2 \cdot \frac{c_r \cdot \frac{t}{r_e^2}}{m}\right] \cdot \frac{c_r}{r_e^2} \quad U_d(1 \cdot \text{yr}, m) = 1.799 \cdot 10^{-5} \cdot \text{day}^{-1}$$

$$t := 0 \cdot \text{yr}, .1 \cdot \text{yr}.. 20 \cdot \text{yr}$$

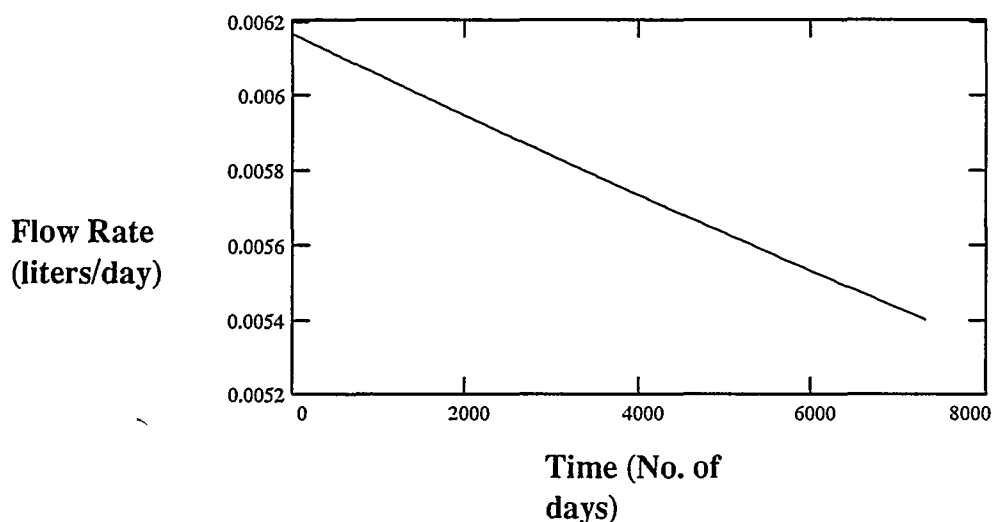

Figure F-4-3

Brine Inflow to a Borehole

F4.3 Conclusion

It will take a very long time for flow to dissipate pore pressure for a radial hole penetrating a 1 cm thick clay seam. DH36, DH38, DH40, DH42, and DH42A all intersect the clay seam B and show the following flow rates:

DH36	0.1	L/Day
DH38	0.03	L/Day
DH40	0.008	L/Day
DH42	0.01	L/Day
DH42A	0.02	L/Day

F5.0 Summary

These order-of-magnitude seepage calculations compare well with the observed seepages into the WIPP excavations. In the case of Room Q, calculated seepage rates are on the order of 0.3 L/day after 1,600 days, where the observable rate is 0.17 L/day (Howarth et al., 1994, Figure 3). In this case, the numerical model is for flow toward the room along a thin clay seam. Extending this model to a waste storage room predicts that total seepage into the room will be on the order of 9,000 L, far short of the 220,000 L necessary to completely corrode the susceptible metals that will be emplaced in it (Deal et al., 1991, Section 4.6). Furthermore, seepage into the room will cease after about 100 years.

The case for seepage into a downhole drilled into strata below a WIPP excavation behaves differently, because flow is radially toward the drillhole. In this case, some seepage continues for a long time, perhaps a thousand years or more. It is clear that seepage into drillholes is strikingly different from seepage into a repository excavation. Deal et al (1993, Section 2.7.2) pointed out that seepage into drillholes probably should not be used to predict long-term seepage into a WIPP Waste Storage Room after sealing and closure. This calculation provides additional support for this caution.

F6.0 References

Carslaw, H. S., and J. C. Jaeger, 1959. "Conduction of Heat in Solids," Oxford at the Clarendon Press, Oxford, England.

Case, J. B., C. A. Givens, and J. R. Tyburski, 1991. "The Geotechnical Effects of Alcove Excavation on Panel 1," *DOE/WIPP 91-017*, U. S. Department of Energy, Carlsbad, NM.

Deal, D. E., and R. A. Bills, 1994, "Conclusions After Eleven Years of Studying Brine at the Waste Isolation Pilot Plant", *Waste Management '94, Tucson, Arizona, March 2, 1994*, IT Corporation, Albuquerque, New Mexico, and Carlsbad Area Office, U. S. Department of Energy, Carlsbad, New Mexico.

Deal, D. E., R. J. Abitz, J. Myers, D. S. Belski, M. L. Martin, D. J. Milligan, R. W. Sobocinski, P. P. James Lipponer, 1993. "Brine Sampling and Evaluation Program: 1991 Report," *DOE-WIPP 93-026*, U. S. Department of Energy, Carlsbad, New Mexico.

Deal, D. E., R. J. Abitz, D. S. Belski, J. B. Case, M. E. Crawley, R. M. Deshler, P. E. Drez, C. A. Givens, R. B. King, B. A. Lauctes, J. Myers, S. Niou, J. M. Pietz, W. M. Roggenthen, J. R. Tyburski, and M. G. Wallace, 1989. "Brine Sampling and Evaluation Program: 1988 Report," *DOE-WIPP-89-015*, U. S. Department of Energy, Carlsbad, New Mexico.

Freeze, R. A. and J. Cherry, 1979. "Groundwater," Prentice Hall, Englewood Cliffs, NJ.

Howarth, S., K. Larson, T. Christian-Frear, R. Beauheim, D. Borns, D. Deal, A.L. Jensen, K. Pickens, R. Roberts, M. Tierney, P. Vaughn, and S. Webb, 1994. "Salado Formation Fluid Flow and Transport Containment Group - White Paper for Systems Prioritization and Technical Baseline, Rev. 1," Prepared by Sandia National Laboratories/New Mexico for the U.S. Department of Energy, Carlsbad, New Mexico.

Scott, R. F., 1963. *Principles of Soil Mechanics*, Addison Wesley, Reading, Massachusetts.

THIS PAGE INTENTIONALLY LEFT BLANK