



DOE/WIPP-95-3117

Waste Isolation Pilot Plant Sealing System Design Report

October 1995

PROPERTY OF
SKEEN-WHITLOCK LIBRARY



Waste Isolation Pilot Plant

DISCLAIMER

This document was prepared as an account of work sponsored by an agency of the United States Government. Neither the United States Government nor any agency thereof, nor any of their employees, makes any warrant, express or implied, or assumes any legal liability or responsibility for the accuracy, completeness, or usefulness of any information, apparatus, product, or process disclosed, or represents that its use would not infringe privately owned rights. References herein to any specific commercial product, process, or service by trade name, trademark, manufacturer or otherwise, does not necessarily constitute or imply its endorsement, recommendation, or favoring by the United States Government or any agency thereof. The views and opinions of authors expressed herein do not necessarily state or reflect those of the United States Government or any agency thereof.

This document has been reproduced directly from the best possible copy. It is available to DOE and DOE contractors at the following address:

Office of Scientific and Technical Information
P.O. Box 62
Oak Ridge, TN 37831

Prices available from (615) 576-8401; FTS 626-8401

**Available to the public from the
National Technical Information Service
U.S. Department of Commerce
5285 Port Royal Road
Springfield, VA 22161**

WIPP Sealing System Design Report

ABSTRACT

This report documents the Waste Isolation Pilot Plant shaft sealing system design. The seals are designed to limit the release of radionuclides and hazardous constituents from an underground nuclear waste repository in salt. Design concepts documented in this report will form the basis for no-migration variance petition modeling. In addition, these concepts are the basis for detailed sealing system design development and evaluations that will be completed in 1996 in support of the planned Compliance Certification Application. The report describes the geologic and hydrologic setting for the seals, presents qualitative and quantitative design guidance, describes the design, documents the sealing materials and their properties, and discusses evaluations of sealing system performance. The design uses a variety of common materials that have very low permeability, demonstrated technologies for construction processes, multiple components to perform each intended function, and the entire length of the shafts to effect a seal system that will meet the performance requirements. For the permanent or long-term seal that resists both gas and brine flow, more than 500 ft of highly compacted crushed salt is used in series with more than 400 ft of clay barriers. The design retards gas flow in the short term using a combination of a rigid concrete barrier (enhanced by an asphalt waterstop) and a compacted clay barrier approximately 100 ft high. Short-term brine flow down the shaft is limited by a clay barrier within the overlying formation and by a combination of more than 500 ft of asphalt, clay, and concrete barriers within the salt.

WIPP Sealing System Design Report

WIPP Sealing System Design Report

WASTE ISOLATION PILOT PLANT
SEALING SYSTEM DESIGN REPORT

Table of Contents

Introduction.....	1
Purpose of this Report.....	1
Report Organization.....	1
Seal Design Development Process.....	2
1.0 Site Geologic and Hydrologic Setting	5
1.1 Regional WIPP Geology and Stratigraphy	5
1.2 Local WIPP Stratigraphy and Groundwater / Brine Occurrence.....	6
1.2.1 Shaft Stratigraphy	6
1.2.2 Regional and Local Groundwater Occurrence in the Rustler Formation and Shallower Units.....	11
1.2.3 Regional and Local Groundwater and Brine Occurrence in the Salado Formation.....	14
2.0 Design Guidance.....	17
2.1 Qualitative Design Guidance and Design Approach	17
2.2 Quantitative Design Guidance for Fluid Flow.....	18
3.0 Design Description.....	21
3.1 Use of the Air Intake Shaft Sealing System Design as a Representative Design for all Shaft Sealing Systems	21
3.2 Air Intake Shaft Sealing System.....	22
3.2.1 Groundwater Migration into the Sealing System.....	22
3.2.2 Brine Reaching the Regulatory Boundaries.....	30
3.2.3 Design Life.....	30
3.2.4 Structural Adequacy.....	31
3.2.5 Subsidence and Accidental Entry	31
3.2.6 Development of New Construction Technologies and/or Materials.....	31
3.3 Design Alternatives.....	32
4.0 Materials	37
4.1 Freshwater Concrete	38
4.2 Salt-Saturated Concrete	38
4.3 Compacted Salt.....	40
4.4 Compacted Clay.....	43
4.5 Asphalt.....	45
4.6 Cementitious Grout.....	46
4.7 Materials Summary.....	46
5.0 Evaluation of Shaft Sealing System Design	49
5.1 Structural Performance	49
5.2 Fluid Flow Evaluation	50
5.2.1 Upper Seal System.....	51
5.2.2 Lower Seal System	52
6.0 Conclusions.....	53
References.....	55

WIPP Sealing System Design Report

WASTE ISOLATION PILOT PLANT
SEALING SYSTEM DESIGN REPORT

Table of Contents (continued)

Appendix A: Results of the Shaft Stratigraphy and Geohydrology EvaluationA-1
Appendix B: Shaft Sealing System DrawingsB-1
Appendix C: A Modeling Study on Shaft Seal PermeabilityC-1
Appendix D: Comparative Analysis of the Seal System DesignD-1

List of Figures

Figure 1-1. Air Intake Shaft stratigraphic profile (upper).....7
Figure 1-2. Air Intake Shaft stratigraphic profile (lower).....9
Figure 1-3. Structural cross section through excavated shafts (based on stratigraphic unit top),
ground surface to top of Salado Formation.....12
Figure 1-4. Structural cross section through excavated shafts (based on stratigraphic unit top),
top of Rustler Formation to total depth.....13
Figure 2-1. Arrangement of the Air Intake Shaft sealing system.19
Figure 3-1. Air Intake Shaft stratigraphy and sealing subsystem profile
(Near Surface/Rustler Formations).....23
Figure 3-2. Air Intake Shaft stratigraphy and sealing subsystem profile (Salado Formation).25
Figure 4-1. Permeability of compacted salt at low hydrostatic stresses.41
Figure 4-2. Estimated permeability of the Salado salt column at 100 years.....42
Figure 4-3. Extent of DRZ at various depths within the shaft.44
Figure 4-4. Relationship between hydraulic conductivity, intrinsic permeability, and
effective clay dry density for selected clay minerals (from Johnson et al., 1994).....45

List of Tables

Table 1-1. Stratigraphic Contacts Unsuitable for Engineering Design Reference.....6
Table 1-2. Regional Intervals of Groundwater Occurrence11
Table 1-3. Observed Brine Seepage Intervals (Salado Formation) Logged during the
Mapping of the Air Intake Shaft15
Table 2-1. Shaft Sealing System Design Guidance18
Table 4-1. Seal Materials for the Salado Formation47
Table 4-2. Material Permeabilities.....47

WIPP Sealing System Design Report

Introduction

Purpose of this Report

This shaft seal report documents the Waste Isolation Pilot Plant (WIPP) shaft sealing system design. Panel closure systems and borehole seal designs will be documented separately. It is intended that the design concepts documented in this report form the basis for no-migration variance petition modeling and detailed design development and evaluations that will be completed in 1996. The detailed design will be documented in a topical report and included as appropriate in the Compliance Certification Application to the Environmental Protection Agency (EPA).

Report Organization

The remainder of this report comprises 6 sections and 4 appendices. The body of the design report does not generally contain detailed backup information; this information is incorporated by reference or in the appendices. This introduction identifies the purpose of the report, explains how the report is organized, and briefly describes the design development process.

Site characteristics that provide the setting into which the seals would be placed are documented in Section 1; these characteristics include the WIPP geology and stratigraphy for both the region and the shafts along with the hydrologic setting for the seals.

Section 2 presents the design guidance used for the shaft seal program. Both qualitative and quantitative guidance are described; the quantitative guidance related to the desired effective permeability of the sealing system is described based on the more detailed discussions presented in Appendix C. Seal-related guidance from applicable regulations is briefly described. The time frame is identified for the performance of various components since some components meet short-term needs while other components are specifically intended to meet long-term (permanent) considerations.

The shaft sealing system is documented in Section 3; somewhat more detail is provided for these design concepts in the drawings provided in Appendix B. The basis for the current concepts is briefly described along with why the Air Intake Shaft (AIS) is used as the model shaft for the sealing system design discussions. For each of the elements of the design guidance identified in Section 2, the approach taken in the design and the related design uncertainties are described. Finally, design alternatives considered during the course of the development of this design are briefly discussed.

Section 4 discusses the materials used in the various seal components and explains why they are expected to function as intended. The material used to seal the shaft cross section is described along with discussions of both interface considerations between the material and the host rock and seal-related considerations in the disturbed rock near the shaft. Material properties including permeability, strength, and mechanical constitutive response are given for each material. Brief discussions of expected performance, construction techniques, longevity, and other characteristics relevant to the WIPP setting are also given.

The performance of the shaft sealing system design is evaluated in Section 5. Performance measures for the shaft sealing system are discussed along with preliminary analyses

WIPP Sealing System Design Report

of the sealing system. Both brine and gas flow considerations are described briefly while more details of some of the analyses are provided in Appendix D.

The sealing system discussions are concluded in Section 6 by summarizing the basis for the conclusion that an effective, implementable design concept has been presented. A section is then provided that documents principal references used in developing this design; the references provide additional information related to discussions contained in the report.

Seal Design Development Process

This report presents a conservative approach to shaft sealing system design. Shaft sealing system performance plays a crucial role in meeting regulatory radionuclide and hazardous constituents release requirements. Although all engineering materials have uncertainties in properties, a combination of available, low-permeability materials can provide an effective sealing system. To reduce system uncertainties and to provide additional assurance of compliance, additional components have been added to this sealing system. Components in this design include long columns of clay, densely compacted crushed salt, a water stop of asphaltic material sandwiched between massive low-permeability concrete plugs, and a column of asphalt. Different materials perform identical functions within the design, thereby adding confidence in system performance.

The design is based on common materials and construction technologies available today. In choosing materials, emphasis was given to permeability characteristics and mechanical properties of seal materials. However, the system is also chemically and physically compatible with the host formations, enhancing long-term performance. Advancements on several fronts have demonstrated that the specified materials can be engineered to create a very low permeability seal while enabling healing of disturbed rock zones (DRZs) within the host Salado Formation. Dense, compacted seal components and rigid concrete components are particularly effective in rapidly enhancing healing of the DRZ in the Salado Formation.

Recent laboratory experiments, construction demonstrations, and field test results have added to the broad and credible database and have supported advances in modeling capability. Results from a series of multi-year, in situ, small-scale seal performance tests show that bentonite and concrete seals maintain very low permeabilities and show no evidence of deterioration in the WIPP environment. A large-scale dynamic compaction demonstration established that crushed salt can be successfully compacted. Laboratory tests show that compacted crushed salt consolidates through creep closure of the shaft from initial conditions achieved in dynamic compaction to a dense salt mass with nearly the same permeability as in situ salt. These technological advancements now allow more credible analysis of the shaft sealing system.

The design was developed through an interactive process involving a design team consisting of technical specialists in the design and construction of underground facilities, materials behavior, rock mechanics analysis, and fluid flow analysis. The design team included specialists drawn from the staff of Sandia National Laboratories, Parsons Brinckerhoff Quade and Douglas, Inc., RE/SPEC Inc., and INTERA Inc. The three contractors were managed by Sandia National Laboratories through a single point of contact. The contractors were required to develop a quality assurance program consistent with the Sandia National Laboratories Quality Assurance Program Description, Revision P and Quality Assurance Procedure 19-1, Computer Software Requirements. All three contractor received quality assurance support visits and were

WIPP Sealing System Design Report

audited through the Sandia National Laboratories audit and assessment program. Quality assurance documentation is maintained in the Sandia National Laboratories WIPP Central Files. In addition to the contractor support, technical input was obtained from consultants in various technical specialty areas.

Technical, management, and QA reviews have been performed on this report under the auspices of the DOE Carlsbad Area Office Management Procedures for Document Review (MP4.2, Rev. 0). Staff from DOE (compliance; operational and experimental program), Westinghouse Waste Isolation Division, the WIPP Technical Assistance Contractor, and Sandia National Laboratories conducted this review. Documentation is in the WIPP Central File.

NOTE

Both English and Standard International (SI) units are used in this report. The construction industry uses English units during preliminary considerations and design, whereas the scientific community uses SI. In general the engineering information is retained in English units consistent with available drawings for WIPP shafts, and SI units are used in the text where the conversion makes sense. Laboratory and field measurements of density, permeability, water content, and discussion of technical results are all in SI units.

WIPP Sealing System Design Report

1.0 Site Geologic and Hydrologic Setting

1.1 Regional WIPP Geology and Stratigraphy

Geologically, the WIPP is located in the Delaware Basin, which began forming approximately 300 million years ago. Rapid subsidence in the early Permian Period resulted in deposition of a sequence of deep-water sandstones, shales, and limestones rimmed by shallow-water limestone reefs. Subsidence slowed during the late Permian Period. Evaporite deposits of the Salado Formation (which hosts the WIPP underground workings) filled the basin and extended over the reef margins. The evaporites, carbonates, and clastic rocks of the Rustler Formation and the Dewey Lake Red Beds were deposited above the Salado Formation near the end of the Permian Period. The Santa Rosa and Gatuña Formations were deposited after the close of the Permian Period.

From the surface downward, the stratigraphic units in the WIPP vicinity above the repository are the Quaternary surface sand sediments, Gatuña Formation, Santa Rosa Formation, Dewey Lake Red Beds, the Rustler Formation, and the Salado Formation. Detailed stratigraphic information on these formations is provided in Holt and Powers (1990). The stratigraphic profile for the Air Intake Shaft (AIS) from the surface to the repository horizon is illustrated in Figures 1-1 and 1-2. The principal stratigraphic units, the Dewey Lake Red Beds, the Rustler Formation and the Salado Formation comprise all but the upper 56 ft (17m) of the geologic section above the WIPP facility.

The Dewey Lake Red Beds, which extend from a mean sea level (MSL) elevation of approximately 3353 ft MSL to 2879 ft MSL, a distance of 474 ft (144 m), consist of alternating layers of reddish-brown, fine-grained sandstone and siltstone cemented with calcite and gypsum (Vine, 1963). The Rustler Formation lies below the Dewey Lake Red Beds and extends from approximately 2879 ft MSL to about 2569 ft MSL, a distance of 310 ft (94 m). This formation, the youngest of the Late Permian evaporite sequence, includes units that provide potential pathways for radionuclide migration from the WIPP. Five units of the Rustler have been described (from youngest to oldest): (1) the Forty-niner Member, (2) the Magenta Dolomite Member, (3) the Tamarisk Member, (4) the Culebra Dolomite member, and (5) an unnamed lower member.

The 250-million-year-old Salado Formation lies below the Rustler Formation. It is about 2000 ft (600 m) thick and consists of three informal members (from youngest to oldest): (1) an upper member (unnamed) composed of reddish-orange to brown halite interbedded with polyhalite, anhydrite, and sandstone, (2) a middle member (the McNutt Potash Zone) composed of reddish-orange and brown halite with deposits of sylvite and langbeinite; and (3) a lower member (unnamed) composed of mostly halite with lesser amounts of anhydrite, polyhalite, and glauberite, with some layers of fine clastic material. These lithologic layers are nearly horizontal at the WIPP, with a regional dip of less than one degree. The WIPP repository is located in the unnamed lower member of the Salado Formation. The facility station level varies between the shafts; however, it is located between 1306 and 1316 feet (398 and 401 m) below the top of the Salado Formation.

1.2 Local WIPP Stratigraphy and Groundwater / Brine Occurrence

To establish the geologic framework required for the design of the WIPP facility shaft sealing system, an evaluation was performed to assess the geologic conditions existing in and between the shafts, where the individual shaft sealing systems will eventually be emplaced. The study evaluated shaft stratigraphy, regional groundwater occurrence, brine occurrence in the exposed Salado Formation section, and the consistency between data recorded on shaft as-built drawings and the actual field data. The following sections discuss shaft stratigraphy, regional groundwater occurrence, and brine occurrence in the exposed Salado Formation section. The complete report of the stratigraphic evaluation results is included in Appendix A.

1.2.1 Shaft Stratigraphy

Four shafts connect the WIPP underground workings to the surface. These shafts are currently identified as the

- Air Intake Shaft (AIS),
- Exhaust Shaft,
- Salt Handling Shaft (formerly referred to as the Exploratory Shaft or the Construction and Salt Handling Shaft), and
- Waste Shaft (formerly referred to as the Ventilation Shaft).

Stratigraphic correlation and evaluation of the unit contacts present in the four shafts indicates that the lithologic units mapped within each shaft during the geologic mapping of the shafts typically have vertical consistency and horizontal continuity, which is demonstrated by the occurrence of lithologic units at approximately the same level in all four shaft locations. Some stratigraphic contact elevations vary because of regional structure and the stratigraphic thinning and thickening of units. However, the majority of the stratigraphic contacts used to date are suitable for engineering design reference because they intersect all four shafts. This stratigraphic consistency is beneficial because it will allow the shaft sealing system to be designed based on the AIS and then applied to the other three shafts with minor adjustments for stratigraphic variations. The ten stratigraphic contacts unsuitable for design reference, because they are not present in all four shafts, are listed in Table 1-1.

Table 1-1. Stratigraphic Contacts Unsuitable for Engineering Design Reference

Stratigraphic Contact	Comment
Mescalero Caliche	Not mapped in air intake and waste shafts.
Gatúña Formation	Not mapped in waste shaft.
Dewey Lake Red Beds	Erosional contact - highly irregular upper surface.
Marker Bed 100	Not present in all four shafts.
Marker Bed 119	Not present in all four shafts.
Marker Bed 120	Not present in all four shafts.
Marker Bed 125	Not present in all four shafts.
Marker Bed 133	Not present in all four shafts.
Marker Bed 137	Not present in all four shafts.
Anhydrite "b"	Not present in all four shafts.
Marker Bed 139	Not present in all four shafts.

STRATIGRAPHY
(SEE NOTE 1)

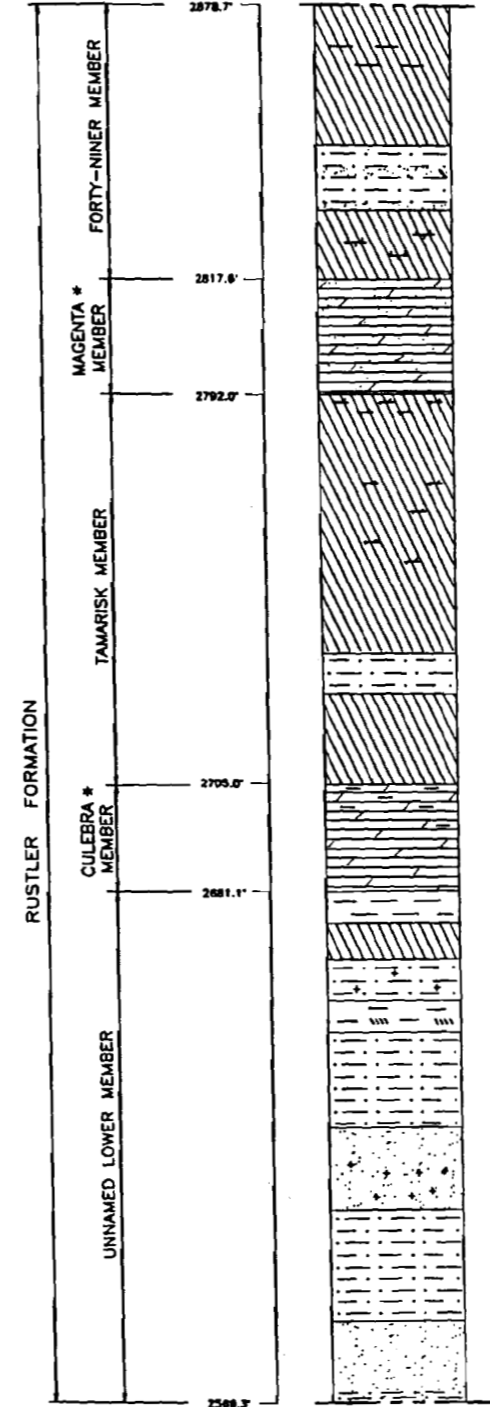
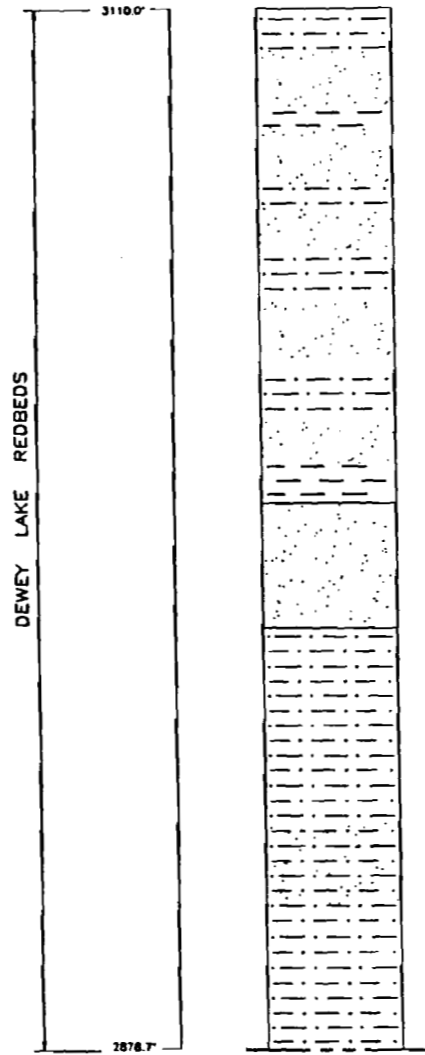
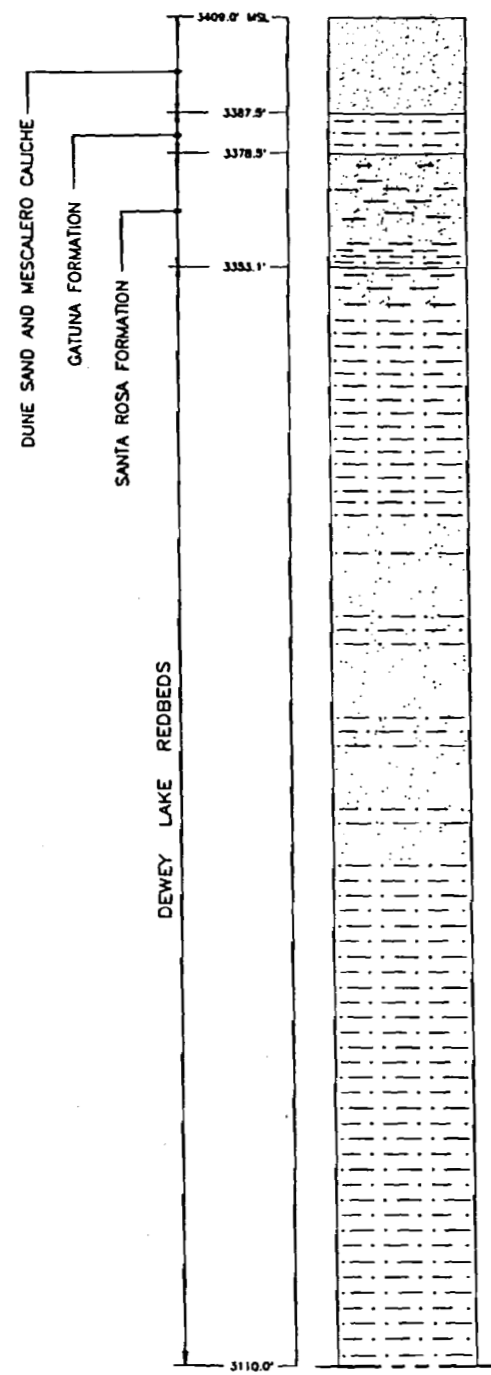

LITHOLOGY:

PRIMARY ROCK/SEDIMENT TYPES	SECONDARY CONSTITUENTS
MUDSTONE/CLAYSTONE	ARGILLACEOUS
CLAYSTONE BED	SILTY
SILTSTONE	SANDY
SANDSTONE	SULFATIC
ANHYDRITE/GYPSUM	DOLOMITIC
DOLOMITE	CALCAREOUS
HALITE	HALITIC
POLYHALITE	POLYHALITIC
	LANGBEINITE

NOTE:

1. THE STRATIGRAPHY AND GROUNDWATER BRINE SEEPAGE/WEEP INTERVALS ARE BASED ON THE LITHOLOGIC INFORMATION COMPILED DURING THE GEOLOGIC MAPPING OF THE AIR INTAKE SHAFT WALLS, DOE/WIPP-90-051, "GEOLOGIC MAPPING OF THE AIR INTAKE SHAFT AT THE WASTE ISOLATION PILOT PLANT", 1990, AND "LETTER REPORT ON THE RESULTS OF THE WASTE ISOLATION PILOT PLANT SHAFT STRATIGRAPHY CORRELATION PROJECT", 1994.

ASTERISK(*) INDICATES GROUNDWATER (RUSTLER/SUPRA RUSTLER FORMATIONS) OR BRINE SEEPAGE/WEEPS (SALADO FORMATION) OBSERVED DURING THE MAPPING OF THE AIR INTAKE SHAFT. AS OF 1994, ONLY MB103 SHOWED VISIBLE MOISTURE ON THE SALADO FORMATION SURFACE EXPOSED WITHIN THE AIR INTAKE SHAFT, "BRINE SAMPLING EVALUATION PROGRAM 1992-1993 REPORT," 1994, DOE-WIPP 94-011.

ABBREVIATION:

ANH.	ANHYDRITE
COL.	COLUMN
CONC.	CONCRETE
D	DIAMETER
DET.	DETAIL
DOE	DEPARTMENT OF ENERGY
DWG.	DRAWING
EL.	ELEVATION
EXIST.	EXISTING
MSL	MEAN SEA LEVEL
TYP.	TYPICAL
VACA TR.	VACA TRISTE
WID	WESTINGHOUSE WASTE ISOLATION DMSION
WIPP	WASTE ISOLATION PILOT PLANT

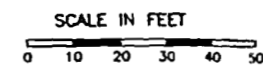

REV.	DATE	DESCRIPTION	BY	CK.	APP.

SANDIA NATIONAL LABORATORIES

WIPP A/E SUPPORT CONTRACT NO: AG-4909

WIPP SHAFT SEALING SYSTEM
NEAR-SURFACE/RUSTLER FORMATIONS

NAME	DATE
BY: WJW	9/5/92
CK: JZ	9/4/92
APP: [Signature]	9/10/92
APP: [Signature]	9/24/92
APP: [Signature]	9/26/92

**AIR INTAKE SHAFT
STRATIGRAPHIC PROFILE**

PARSONS BRINCKERHOFF ENERGY SERVICES, INC.	SCALE:	SIZE:	SNL DWG. NO.	SHEET NO.
		B	33-SNL-003	1 OF 2

Figure 1-1.

STRATIGRAPHY
(SEE NOTE 1 OF SHEET NO. 1)

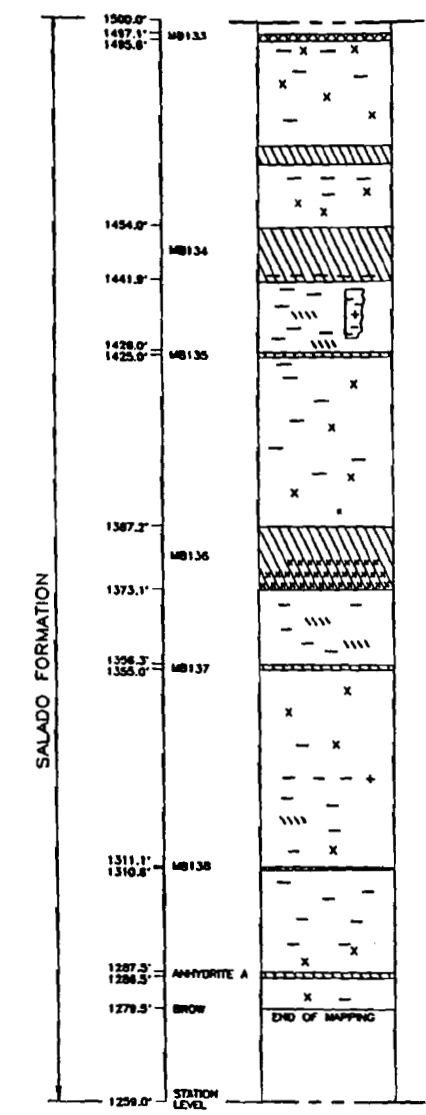
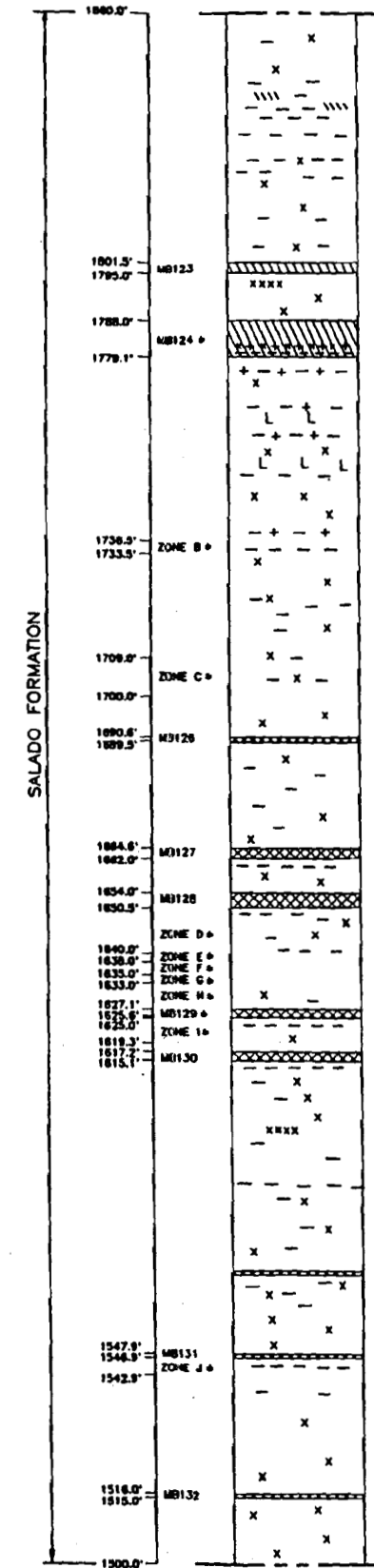
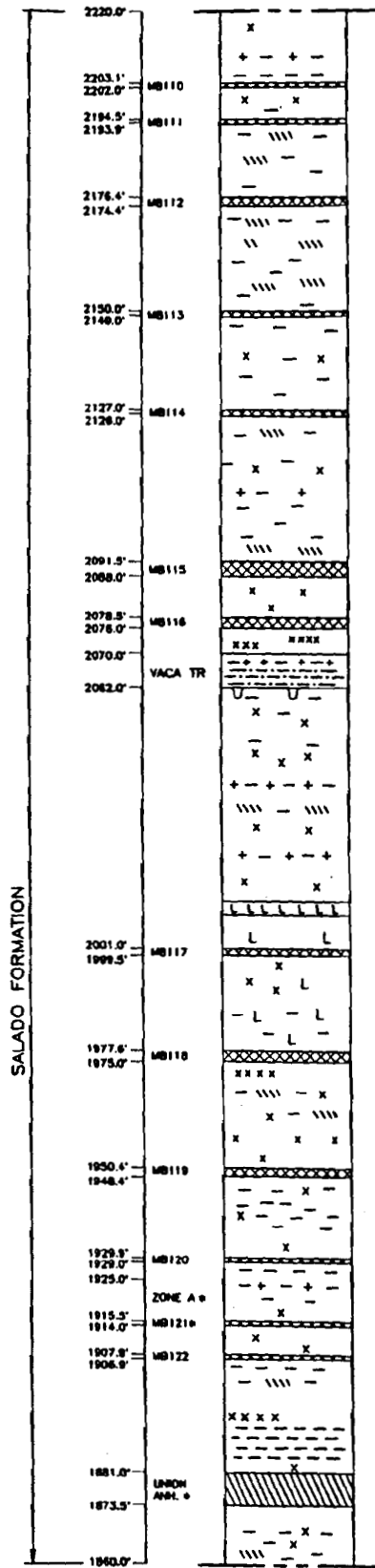
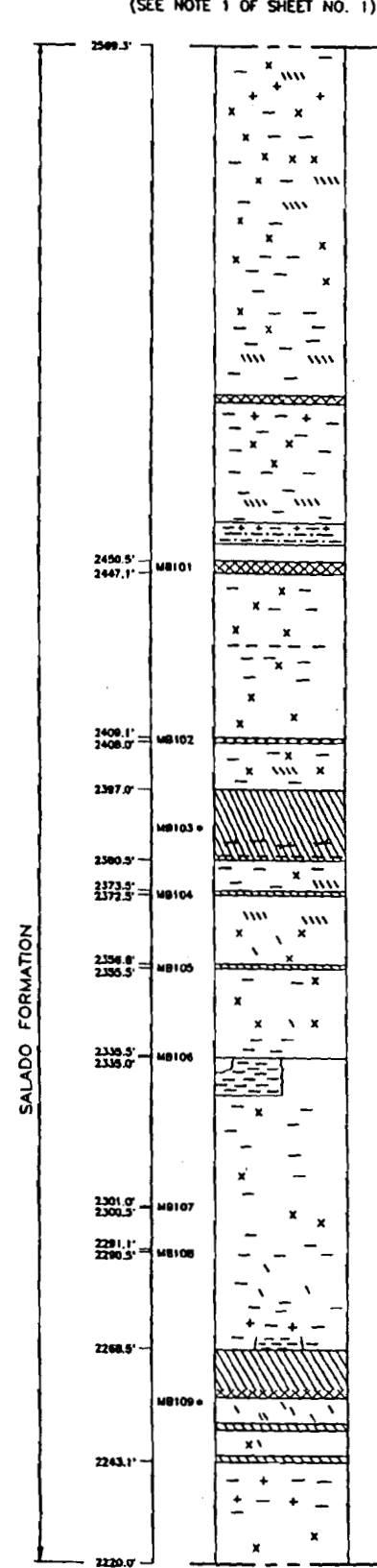

- LITHOLOGY:**
- PRIMARY ROCK/SEDIMENT TYPES**
- MUDSTONE/CLAYSTONE
 - CLAYSTONE BED
 - SILTSTONE
 - SANDSTONE
 - ANHYDRITE/GYPSUM
 - DOLOMITE
 - HALITE
 - POLYHALITE
- SECONDARY CONSTITUENTS**
- ARGILLACEOUS
 - SILTY
 - SANDY
 - SULFATIC
 - DOLOMITIC
 - CALCAREOUS
 - HALITIC
 - POLYHALITIC
 - LANGBEINITE

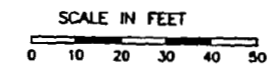

REV.	DATE	DESCRIPTION	BY	CK.	APP.
SANDIA NATIONAL LABORATORIES					
WIPP A/E SUPPORT				CONTRACT NO: AG-8908	
WIPP SHAFT SEALING SYSTEM SALADO FORMATION				NAME	DATE
AIR INTAKE SHAFT STRATIGRAPHIC PROFILE				BY	
				CK.	
				APP.	
				APP.	
PARSONS BRINCKERHOFF ENERGY SERVICES, INC		SCALE:	SIZE:	SNL DWG. NO.	SHEET NO.
				33-SNL-003	2 OF 2

Figure 1-2

WIPP Sealing System Design Report

Figures 1-3 and 1-4 are structural cross sections based on MSL elevations that illustrate the typical consistency of stratigraphic unit contacts both vertically and horizontally among the four shafts. With the exception of the 11 lithologic units listed above in Table 1-1, all of the unit contacts and marker beds shown in Figures 1-3 and 1-4 are suitable for reference for the shaft sealing system design. It should be noted that there is a 440-ft (122-m) north-south offset between the Salt Handling Shaft and the Waste Shaft, as indicated on the figure legends.

1.2.2 Regional and Local Groundwater Occurrence in the Rustler Formation and Shallower Units

Geohydrological surveys of the WIPP site have identified six regional intervals of groundwater occurrence (Beauheim and Holt, 1990). These intervals are listed in Table 1-2.

Table 1-2. Regional Intervals of Groundwater Occurrence

Stratigraphic Unit	Remarks
Rustler Formation	
Forty-niner Member	Aquitard; water producing unit is a claystone interbedded with anhydrite and or gypsum units.
Magenta Dolomite Member	Regional aquifer; consists of fine grained gypsiferous arenaceous dolomite.
Tamarisk Member	Aquitard; consists of claystone sandwiched between two anhydrites.
Culebra Dolomite Member	Regional aquifer; consists of a finely crystalline, locally argillaceous and arenaceous, vuggy dolomite.
Unnamed Lower Member	Aquitard; consists of interbedded siltstone, sandstone, halite, and anhydrite. Regionally has two water producing units; however only one is present at the WIPP site. It is characterized by low permeability.
Rustler/Salado Formation Contact	Groundwater seeps at formation contact; general area of "brine aquifer" at Nash Draw

The Dewey Lake Red Beds geologic unit is not a regionally productive source of water. Drilling has identified only a few localized zones of relatively high permeability (Mercer, 1983; Beauheim, 1987). In the Rustler Formation most groundwater flow occurs in the Culebra Dolomite and Magenta Dolomite members, as well as in the Rustler-Salado contact residuum or "brine aquifer" in the vicinity of Nash Draw (Beauheim and Holt, 1990). The other units (the Forty-niner Member, Tamarisk Member, and Unnamed Lower Member) are considered aquitards (a confining bed that retards but does not prevent the flow of water to or from an adjacent aquifer) because of their low permeability throughout the area. Groundwater near the WIPP usually contains large concentrations of total dissolved solids. Moisture at the Rustler-Salado contact was observed in the Salt Handling Shaft but not the other three shafts. The only discussion of seepage rates in the references used for the stratigraphic evaluation was related to the Rustler Formation.

WIPP Sealing System Design Report

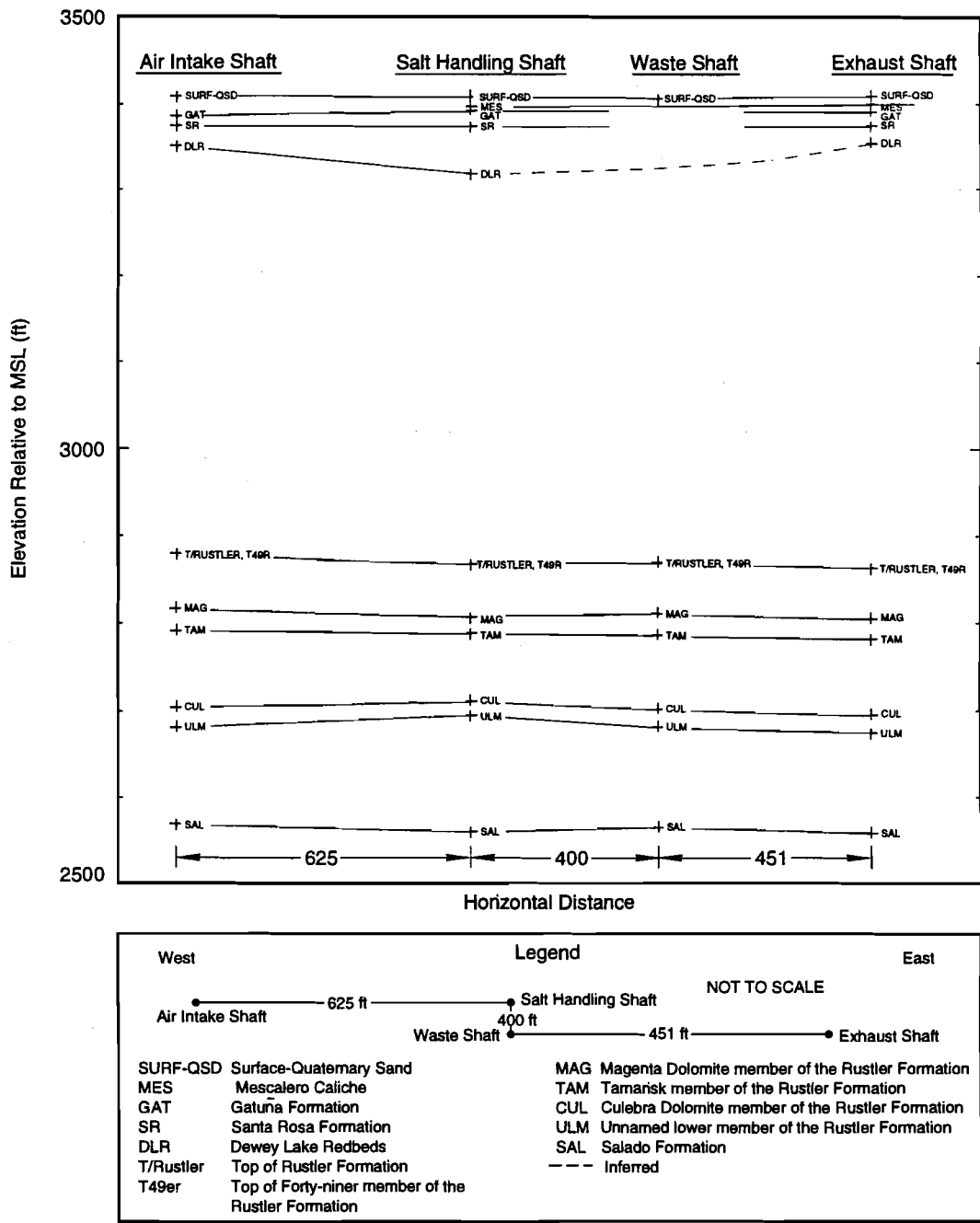

TRI-6121-212-3

Figure 1-3. Structural cross section through excavated shafts (based on stratigraphic unit top), ground surface to top of Salado Formation.

WIPP Sealing System Design Report

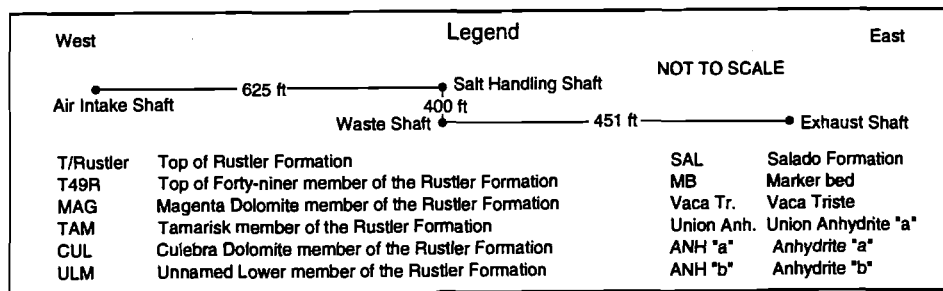
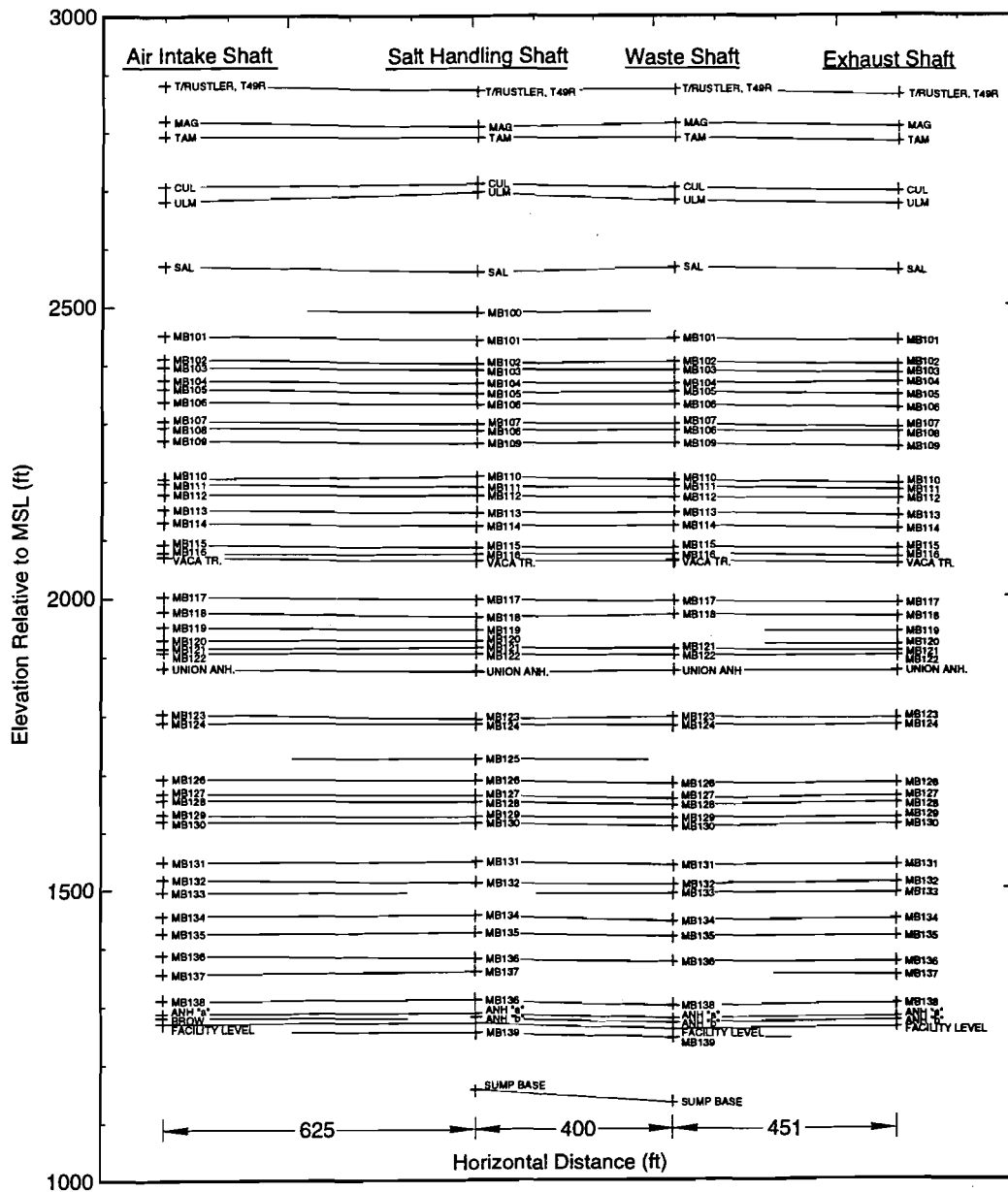

TRI-6121-211-4

Figure 1-4. Structural cross section through excavated shafts (based on stratigraphic unit top), top of Rustler Formation to total depth.

1.2.3 Regional and Local Groundwater and Brine Occurrence in the Salado Formation

The Salado Formation has not been disturbed by post-depositional processes such as structural deformation and dissolution in the WIPP area. The formation is assumed to be brine-saturated throughout the WIPP area because of the presence of a regional hydrostatic pressure gradient (Mercer, 1983). Groundwater (brine) flow within it is extremely low because primary porosity and open fractures are lacking in the salt (Mercer, 1983) and low permeability, averaging 5.0×10^{-20} m², allows for little groundwater movement (Powers et al., 1978). Groundwater found in the Salado Formation appears in the form of seeps and weeps and is salt saturated.

The shafts were evaluated for intervals of brine seepage occurrence below the Rustler-Salado Formation contact within the exposed Salado Formation section. Of the four shafts, brine seepage in this interval was observed and noted only in the AIS during shaft mapping. However, the identified brine seepage intervals in the AIS have been projected to the other shafts—for shaft sealing system design purposes—in anticipation that these seepage intervals may be present in all four of the shafts (see Appendix A). There were no notations indicating volume quantities of brine seepage in the references used for the stratigraphic evaluation. Four of the seventeen intervals observed in the AIS (MB 103, MB 124, Vaca Triste siltstone, and Union Anhydrite) were identified during the AIS mapping as primary brine-producing intervals in the Salado Formation (Holt and Powers, 1990). Ten of the seventeen seepage intervals were not named when the shaft was mapped. These intervals have subsequently been designated as zones A through J (see Appendix A). Seepage (i.e., seeps and weeps) observed in the exposed Salado Formation AIS has not been quantified but can be contrasted with recorded water-inflow data from the Rustler Formation water bearing units, which flowed less than a total of 1.5 gallons per minute into the shaft prior to liner installation. After liner installation, the inflow rate dropped to less than 0.1 gallon per minute (Jarolimek et al., 1983). The terms *weeps* and *seeps*, which refer to low volume fluid flow, such as water oozing from the rock, are used to describe brine occurrence in the Salado Formation exposed in the AIS. The unquantified seepage in the Salado Formation is minor in comparison to the Rustler Formation flow rates after liner installation.

The identified intervals from the AIS lithologic log are presented in Table 1-3. A recent observation (July 1994) of seepage intervals within the AIS was conducted as part of the Brine Sampling and Evaluation Program (BSEP). These recent observations indicated the presence of salt encrustations in 73 locations, including the surfaces of the brine seepage intervals identified during shaft mapping; however, only the salt encrustations on the surface of Marker Bed 103 were observed to be wet (Deal et al., 1995).

WIPP Sealing System Design Report

Table 1-3. Observed Brine Seepage Intervals (Salado Formation) Logged during the Mapping of the Air Intake Shaft

Stratigraphic Unit/ Engineering Feature	Unit/Feature Top (ft-MSL)	Unit/Feature Bottom (ft-MSL)	Comments
Salado Formation	2569.3	Did not penetrate	Regional potential for groundwater (brine) occurrence at the Rustler/Salado Formation contact; (Holt & Powers, 1990). No groundwater at contact noted on lithologic log. Shaft did not penetrate base of unit.
Marker Bed 103	2397.0	2380.5	Brine; Weeps - moist surface in lower 4 ft; Anhydritic dolomite overlying claystone where weeps occur (Holt & Powers, 1990).
Marker Bed 109	2268.5	2243.1	Brine; Weeps: weep symbol on log with no weep description. Weeps occur in mudstone with anhydrite nodules (Holt & Powers, 1990).
Vaca Triste	2070.0	2062.0	Brine (Holt & Powers, 1990). Composed of halitic siltstone and mudstone.
Zone A	1925.0	1915.5	Brine; Some weeps, halite with a trace of polyhalite: AIS log (Holt & Powers, 1990).
Marker Bed 121	1915.5	1914.0	Brine; Weeps: AIS log. Weep symbol on log near base of unit (polyhalite) - no description. 2-3" clay at base (Holt & Powers, 1990).
Union Anhydrite	1881.0	1873.5	Brine; Unit as a whole bears fluid. Weeps parallel to strata are very common around zones with clastic halite. Weeps occur also around fractures and contacts. AIS log (Holt & Powers, 1990).
Marker Bed 124	1788.0	1779.1	Brine; Recent weeps parallel to fractures and bedding planes in anhydrite: AIS log (Holt & Powers, 1990).
Zone B	1736.5	1733.5	Brine; Abundant weeps, halite argillaceous to trace clay: AIS log (Holt & Powers, 1990).
Zone C	1709.0	1700.0	Brine; Modest amount of weeps, halite, trace clay and polyhalite: AIS log (Holt & Powers, 1990).
Zone D	1650.5	1640.0	Brine; Weeps in lower most part, interbedded polyhalite and argillaceous halite: AIS log (Holt & Powers, 1990).
Zone E	1640.0	1638.0	Brine; Weeps in pits, argillaceous halite: DOE-AIS log (Holt & Powers, 1990).
Zone F	1638.0	1635.0	Brine; Moderate weeps in unit, halite with trace polyhalite and clay: AIS log (Holt & Powers, 1990).
Zone G	1635.0	1633.0	Brine; Abundant weeps from pits, argillaceous halite and halitic claystone: AIS log (Holt & Powers, 1990).
Zone H	1633.0	1627.1	Brine; Moderate weeps, halite and polyhalite: AIS log (Holt & Powers, 1990).
Marker Bed 129	1627.1	1625.6	Brine; Abundant weeps: AIS log (Holt & Powers, 1990).
Zone I	1625.0	1619.3	Brine; Weeps, halite with polyhalite and claystone interbeds: AIS log (Holt & Powers, 1990).
Zone J	1546.9	1542.9	Brine; Abundant weeps, halite trace to some clay and polyhalite: AIS log (Holt & Powers, 1990).

WIPP Sealing System Design Report

2.0 Design Guidance

The WIPP is subject to numerous regulatory requirements. The use of both engineered and natural barriers to isolate wastes from the accessible environment is required by 40 CFR 191.14(d). Quantitative requirements for potential releases of radioactive and other hazardous materials from the repository system are specified in 40 CFR 191 and 40 CFR 268. The regulations do not impose quantitative requirements on individual components of the repository sealing system.

The absence of regulatory requirements at the component level allows repository designers to identify and assess the components and component parameters that have the greatest impact on potential releases from the repository. For example, a preliminary assessment of the "undisturbed performance" of the WIPP (WIPP PA Department, 1993) identified four parameters associated with the waste form, one parameter associated with the site, and the shaft sealing system permeability as "*very important*" when repository performance is compared to the regulatory requirements.

The guidance described for the design of the shaft sealing system in this section addresses the need for the WIPP to comply with system requirements noted above and to follow accepted engineering practices using demonstrated technology. The design guidance addresses the need to limit:

1. radiological or other hazardous constituents reaching the regulatory boundaries,
2. groundwater flow into and through the sealing system,
3. chemical and mechanical incompatibility,
4. structural failure of system components,
5. subsidence and accidental entry,
6. development of new construction technologies and/or materials.

Qualitative design guidance and design approach for the shaft sealing system are presented in Section 2.1. Quantitative design guidance for fluid flow is presented in Section 2.2. Qualitative as well as quantitative guidance is applicable to the design described in Section 3.0, but quantitative guidance serves as the basis for the evaluation of the sealing system presented in Section 5.0. Because the shaft sealing system depends in part on assumptions made in other parts of the repository system, the quantitative design guidance for the shaft sealing system may change as the evaluation of the total repository system performance progresses. For example, the need to retard gas flow is dependent on assumptions related to waste form, brine availability, etc.

2.1 Qualitative Design Guidance and Design Approach

Table 2-1 contains qualitative design guidance and the design approach used to implement it.

Table 2-1. Shaft Sealing System Design Guidance

Qualitative Design Guidance	Design Approach
The shaft sealing system shall limit:	The shaft sealing system shall be designed to meet the qualitative design guidance in the following ways:
1. the migration of radiological or other hazardous constituents from the repository horizon to the regulatory boundary during the 10,000-year regulatory period following closure;	1. brine migrating from the repository horizon to the Rustler Formation must pass through a low permeability sealing system;
2. groundwater flowing into and through the shaft sealing system;	2. groundwater migrating from the Rustler Formation to the repository horizon must pass through a low permeability sealing system ;
3. chemical and mechanical incompatibility of seal materials with the seal environment;	3. the sealing system materials are chemically and mechanically compatible with the seal environment or can be protected;
4. the possibility for structural failure of individual components of the sealing system;	4. structural analysis shows that each component is adequate to withstand the forces expected from rock creep and hydraulic pressure;
5. the possibility for subsidence of the ground surface in the vicinity of the shafts and accidental entry after sealing;	5. the shaft is completely filled with low porosity materials, and construction equipment would be needed to gain entry;
6. the need to develop new technologies or materials for construction of the shaft sealing system.	6. construction of the shaft sealing system is feasible using available technologies and materials.

2.2 Quantitative Design Guidance for Fluid Flow

Quantitative guidance is derived from 40 CFR 191 and 40 CFR 268. These design concerns involving fluid flow are design-specific. The shaft sealing system has been designed to control migration of radionuclides and other hazardous materials from the time of repository closure. The shaft sealing system is depicted in Figure 2-1. Control is achieved by utilizing shaft sealing system components constructed of asphalt, clay, and concrete that will be effective upon emplacement and a compacted salt component that will become effective during the 100 years following emplacement. The upper clay component and the consolidated salt component constitute long-term barriers (lasting through the 10,000-year regulatory period and beyond) to fluid flow for the sealing system. (The 100 years following repository closure are referred to as the “short term”; the 100 to 10,000-year period is referred to as the “long term.”) The asphalt and concrete components provide additional assurance that the sealing system will be effective during the consolidation period for the salt component (the 100 years following closure).

WIPP Sealing System Design Report

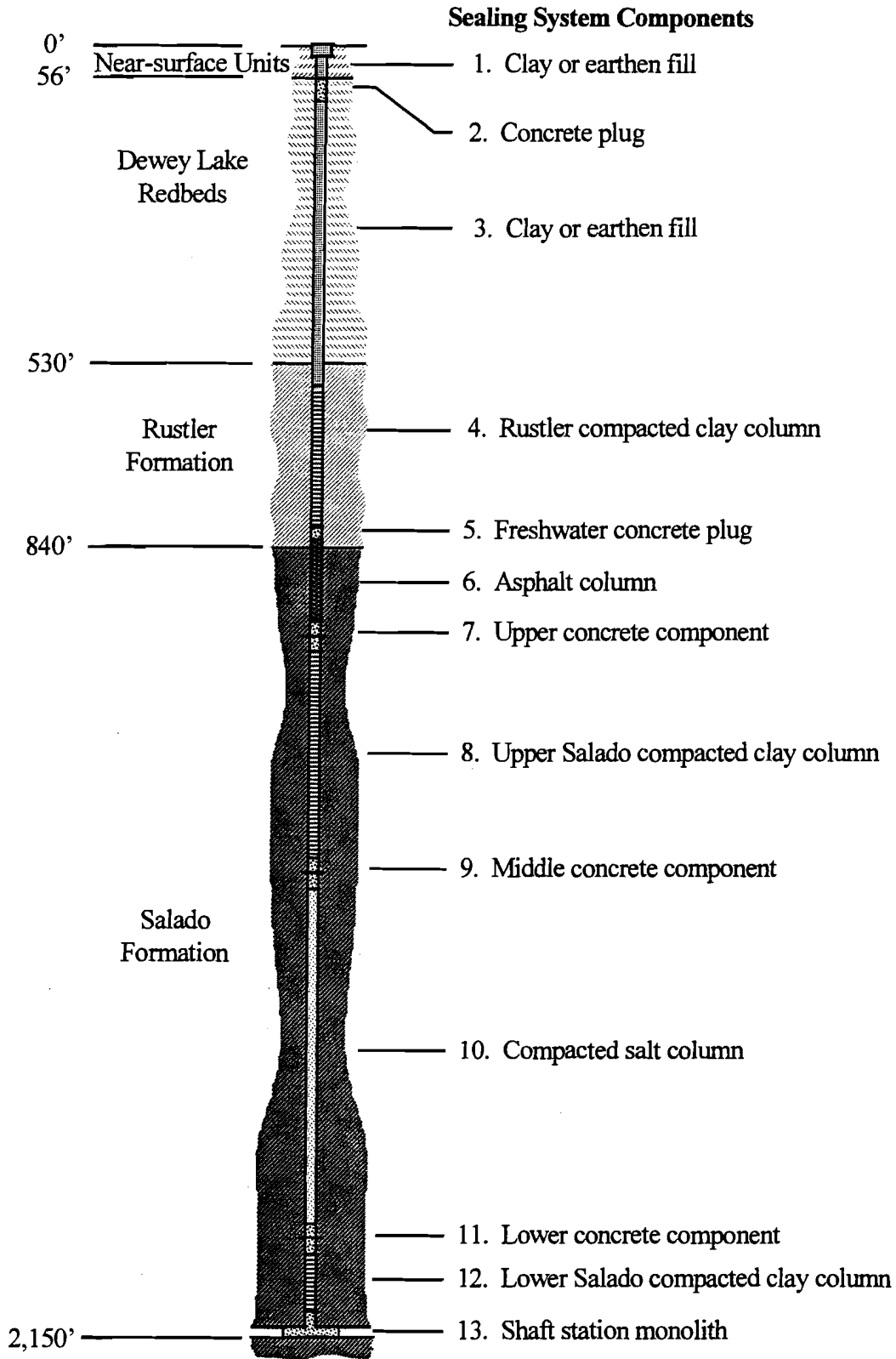

Figure 2-1. Arrangement of the Air Intake Shaft Sealing System.

WIPP Sealing System Design Report

Fluid flow provides the principal mechanism for radiological or other hazardous constituents to be transported from the repository to the regulatory boundaries. As a consequence, the approach taken to isolate these materials is limiting fluid flow through the sealing system.

The Rustler Subsystem consists of Components 4 and 5. It extends from the base of the Near-Surface Subsystem to within 16 ft (5 m) of the Rustler-Salado Contact, a distance of 255 ft (79 m). In both the short term and long term, this subsystem shall limit the flow of groundwater from the Rustler Formation into and through the shaft and assist in limiting accidental entry and subsidence. The Rustler compacted clay column (Component 4) shall provide short-term and long-term separation of water bearing zones in the Rustler.

The Salado Formation Subsystem is divided into two elements, hereafter referred to as the upper seal system and the lower seal system. The upper seal system consists of Components 6 through 9 and extends from the bottom of the Rustler Subsystem to the bottom of the middle concrete component, a distance of 582 ft (177 m). In the short term, the upper seal system shall limit the flow of Rustler-Salado Contact groundwater into and through the shaft. In the long term, the upper Salado clay column (Component 8) shall act as a permanent barrier to the flow of brine and gas. The lower seal system consists of Components 10, 11, and 12. It extends from the bottom of the upper seal system to the shaft station monolith (Component 13), a distance of 707 ft (215 m). The monolith is the structural component that stabilizes and limits deformation of the shaft station area. In the short term, the lower concrete component (Component 11) and the lower Salado compacted clay column (Component 12) shall retard the flow of brine and gas from the repository into the compacted salt column. The compacted salt column will consolidate during the short term and shall serve as a permanent (long-term) barrier to the flow of brine and gas. The lower Salado compacted clay column shall also act as a barrier to the flow of brine and gas during the long term.

Modeling studies have provided quantitative design guidance for limits of brine or gas flow through the total sealing system. These studies (presented in Appendix C) have shown for a shaft sealing system having the equivalent of 100 m in length:

- a permeability of 10^{-16} m² limits brine flow, and
- permeabilities of less than 10^{-18} m² reduce gas flow.

In addition, a design assumption has been made that gas generation in the waste region during the 100 years following seal construction will not result in pressure differences in excess of 2 MPa through the shaft sealing systems.

3.0 Design Description

The design presented in this section was developed to limit the release of radioactive materials and hazardous constituents to levels that are below regulatory limits. This design is based on the design guidance outlined in Section 2.0, past designs, the desire to reduce the uncertainties associated with the performance of sealing system, and the need to effectively seal the shaft wall disturbed rock zone (DRZ) at the time the sealing system is installed. Knowledge related to the ability to compact salt to high densities, which was gained from recent experimental results, has also been used in the design.

The past designs are:

- the initial reference seal system design (Nowak et al., 1990),
- the seal design alternative study (Van Sambeek et al., 1993), and
- the sealing system for a representative WIPP shaft (Hansen et al., 1995).

The sealing system design has progressed over the past five years from the initial concepts presented by Nowak (1990) to the concepts presented in this document. The design changes were implemented to take advantage of knowledge gained from small scale seals tests conducted at the WIPP, salt compaction tests and laboratory determination of the permeability of compacted salt samples conducted by Sandia National Laboratories, advances in the ability to predict the time-dependent mechanical behavior of the intact salt rock, and technical studies.

Reduction of the uncertainty associated with long-term performance is addressed by replacing the upper and lower Salado Formation salt columns used in the earlier designs with compacted clay columns and by adding an asphalt sealing component in the Salado Formation. Use of different materials for sealing system components reduces the uncertainty associated with a common-mode failure. The compacted salt column provides a seal with an initial permeability several orders of magnitude higher than the clay or asphalt columns but with long-term properties approaching those of the host rock. The use of clay also allows testing of the "as-emplaced" material to verify that the values for permeability used in design are achieved in the field. Asphalt provides an assured seal of the shaft cross section and the interface at the time of installation. Sealing of the DRZ at the time of installation is addressed by grouting in the Rustler Formation and including an asphalt waterstop in each of the concrete components in the Salado Formation. Recent experimental results (Ahrens and Hansen, 1995) established that crushed salt can be compacted to an initial density that is at or near 90 percent of the density of undisturbed salt. These materials are used in concert to reduce overall uncertainty of the seal system.

3.1 Use of the Air Intake Shaft Sealing System Design as a Representative Design for all Shaft Sealing Systems

The stratigraphy at the WIPP site is uniform from shaft to shaft. As noted in Section 1.1, a few of the marker beds are not present in all shafts, and some thinning and thickening of lithologic units exist, but typically the units have vertical consistency and horizontal continuity. Vertical consistency is demonstrated by the fact that shaft mapping shows relatively little change in the elevation of marker beds and thickness of units when all four shafts are considered, and horizontal continuity is demonstrated by the fact that the shaft mapping reports show all major geologic formations and almost all marker beds to be present at all four shaft locations. The sources for potential groundwater (Appendix A, Sect. 3) are the same for all four WIPP shafts, as is the source for gas and brine. Groundwater sources are the Culebra and Magenta Members of

the Rustler Formation, the Rustler-Salado Contact Zone, and several Marker Beds in the Salado Formation. The waste emplacement area of the repository is the source for gas and brine. The waste emplacement area is connected to the shafts by the access drifts, marker beds, and the DRZ. Because the stratigraphy is consistent and the sources for groundwaters, gas, and brine are the same; a sealing system developed for the Air Intake Shaft (AIS) can be used to seal the remaining WIPP shafts. Adjustments in the diameter of components and minor adjustments in component locations, to suit shaft-specific variations in the stratigraphy, will be required in each of the remaining shafts. The AIS was selected as the model shaft for design of the sealing system because the shaft mapping report (Holt and Powers, 1990) describes the stratigraphy in greater detail than the mapping reports for the other shafts.

The Waste Shaft and Salt Handling Shaft have sumps, while the AIS and Exhaust Shaft do not have sumps. The sumps will be backfilled at closure to provide a base for construction of the shaft sealing system. This backfill is not relied on to perform a sealing function. Therefore, the absence of a sump in the AIS does not adversely impact the design of the shaft sealing system.

3.2 Air Intake Shaft Sealing System

The general arrangement of the shaft sealing system is shown in Figures 3-1 and 3-2. A complete set of design drawings is included in Appendix B. The AIS sealing system design was developed to meet the design guidance presented in Section 2.0 of this document. This section discusses, qualitatively, how each of the elements of design guidance is addressed by the design. In Section 5.0 an evaluation of the design's ability to meet the objectives is presented. To facilitate discussion, each of the sealing system components has been assigned a unique number and a descriptive name. The component numbers and names are presented in Figure 2-1.

Each of the elements of the design guidance is addressed in this discussion. The migration of groundwater into and through the sealing system is discussed first because it offers an opportunity to introduce each of the sealing system components in order from the surface to the repository horizon. The guidance on brine reaching the accessible environment is discussed next, and the remaining guidance elements are discussed in the same order as they are listed above in Table 2-1.

3.2.1 Groundwater Migration into the Sealing System

- a. **Design Guidance.** The shaft sealing system shall limit groundwater flowing into and through the shaft sealing system.
- b. **Source of Groundwater.** During the mapping of the AIS, brine was observed entering the shaft from the Magenta and Culebra members of the Rustler Formation, the Rustler-Salado Formation contact zone, and 17 brine seepage intervals in the Salado Formation (Section 1.2). The region between the surface and the upper Salado Formation was mapped in the fall of 1988, and the remainder of the Salado Formation was mapped in the fall of 1989. The quantity of brine migrating into the shaft was small: the Rustler Formation water bearing zones were estimated to have an inflow rate of 1.5 gpm before the shaft lining was installed and 0.1 gpm after liner installation. Only one of the 17 brine seepage intervals in

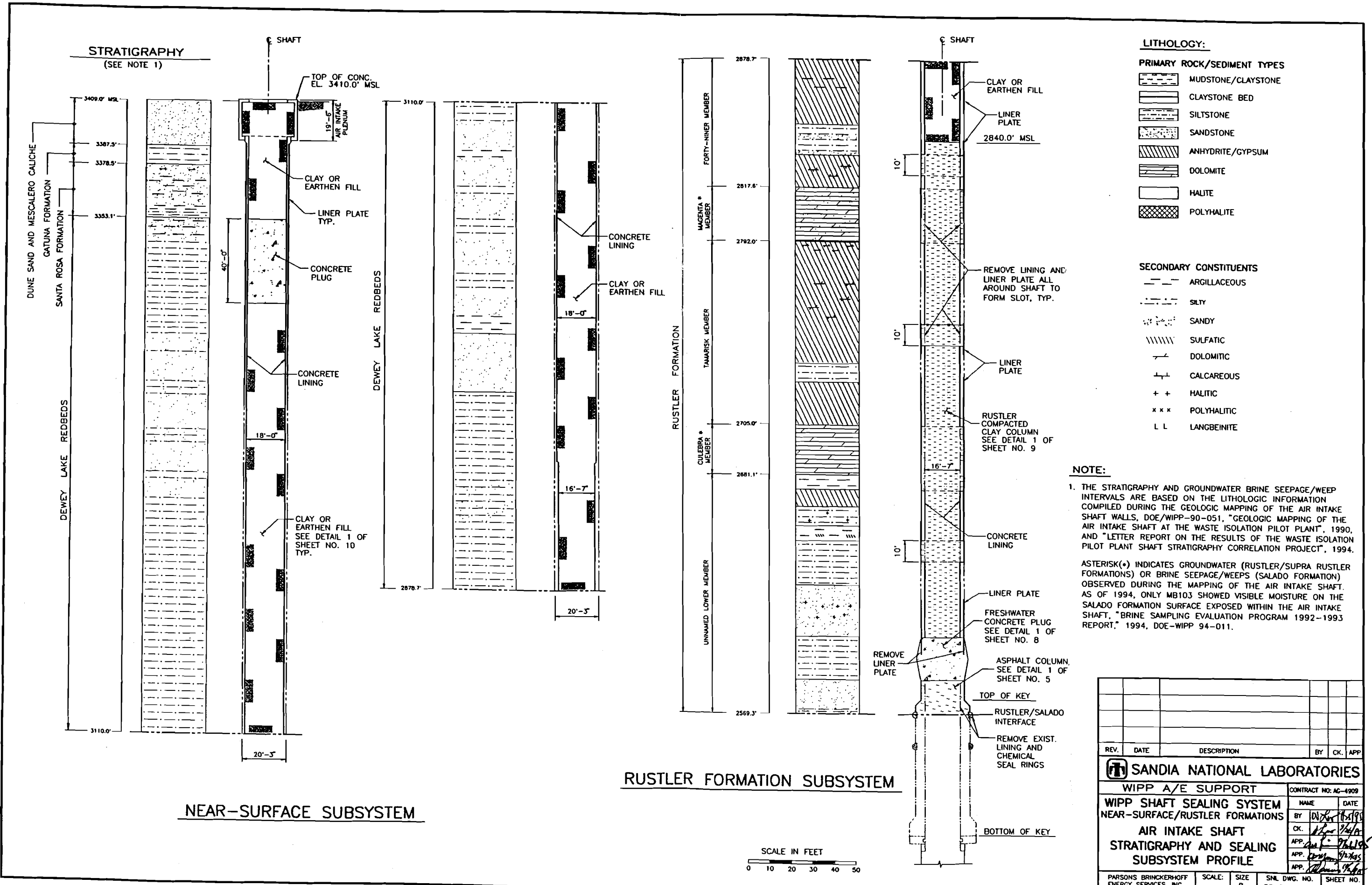

STRATIGRAPHY
(SEE NOTE 1)

LITHOLOGY:

PRIMARY ROCK/SEDIMENT TYPES

- MUDSTONE/CLAYSTONE
- CLAYSTONE BED
- SILTSTONE
- SANDSTONE
- ANHYDRITE/GYPSUM
- DOLOMITE
- HALITE
- POLYHALITE

SECONDARY CONSTITUENTS

- ARGILLACEOUS
- SILTY
- SANDY
- SULFATIC
- DOLOMITIC
- CALCAREOUS
- HALITIC
- POLYHALITIC
- LANGBEINITE

NOTE:

1. THE STRATIGRAPHY AND GROUNDWATER BRINE SEEPAGE/WEEP INTERVALS ARE BASED ON THE LITHOLOGIC INFORMATION COMPILED DURING THE GEOLOGIC MAPPING OF THE AIR INTAKE SHAFT WALLS, DOE/WIPP-90-051, "GEOLOGIC MAPPING OF THE AIR INTAKE SHAFT AT THE WASTE ISOLATION PILOT PLANT", 1990, AND "LETTER REPORT ON THE RESULTS OF THE WASTE ISOLATION PILOT PLANT SHAFT STRATIGRAPHY CORRELATION PROJECT", 1994.

ASTERISK(*) INDICATES GROUNDWATER (RUSTLER/SUPRA RUSTLER FORMATIONS) OR BRINE SEEPAGE/WEEPS (SALADO FORMATION) OBSERVED DURING THE MAPPING OF THE AIR INTAKE SHAFT. AS OF 1994, ONLY MB103 SHOWED VISIBLE MOISTURE ON THE SALADO FORMATION SURFACE EXPOSED WITHIN THE AIR INTAKE SHAFT. "BRINE SAMPLING EVALUATION PROGRAM 1992-1993 REPORT," 1994, DOE-WIPP 94-011.

REV.	DATE	DESCRIPTION	BY	CK.	APP.

SANDIA NATIONAL LABORATORIES
WIPP A/E SUPPORT
WIPP SHAFT SEALING SYSTEM
NEAR-SURFACE/RUSTLER FORMATIONS
AIR INTAKE SHAFT
STRATIGRAPHY AND SEALING
SUBSYSTEM PROFILE

CONTRACT NO. AG-4909

NAME	DATE
BY: <i>[Signature]</i>	11/21/98
CK: <i>[Signature]</i>	12/14/98
APP: <i>[Signature]</i>	1/16/99
APP: <i>[Signature]</i>	9/14/98
APP: <i>[Signature]</i>	1/16/99

PARSONS BRINCKERHOFF ENERGY SERVICES, INC. SCALE: SIZE B SNL DWG. NO. 33-SNL-005 SHEET NO. 1 OF 10

RUSTLER FORMATION SUBSYSTEM

NEAR-SURFACE SUBSYSTEM

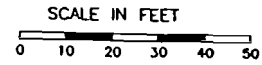
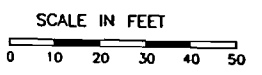
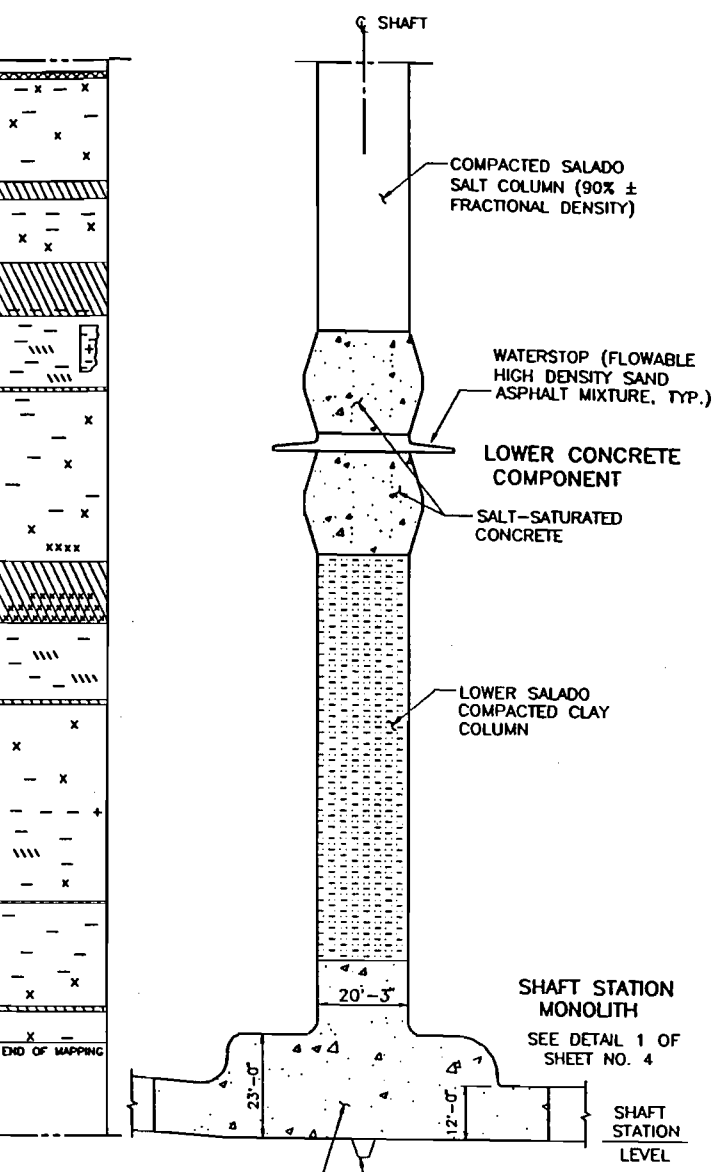
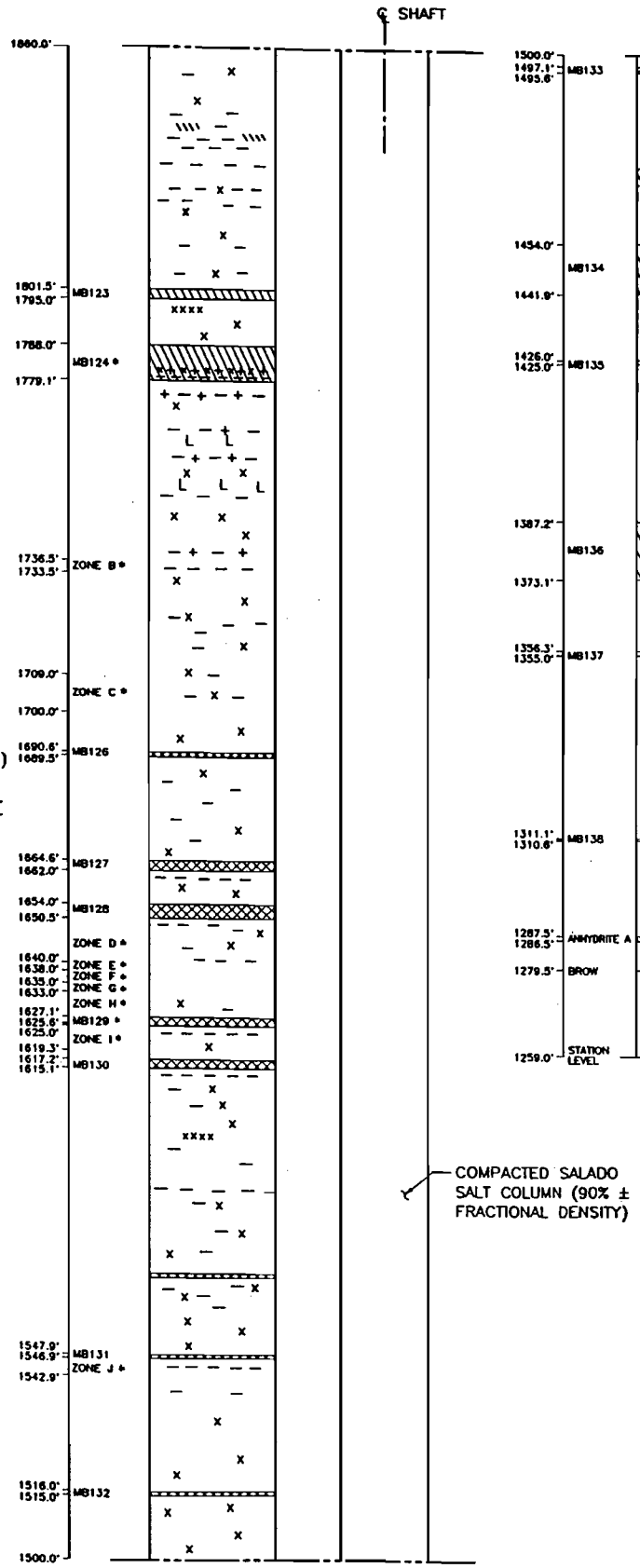
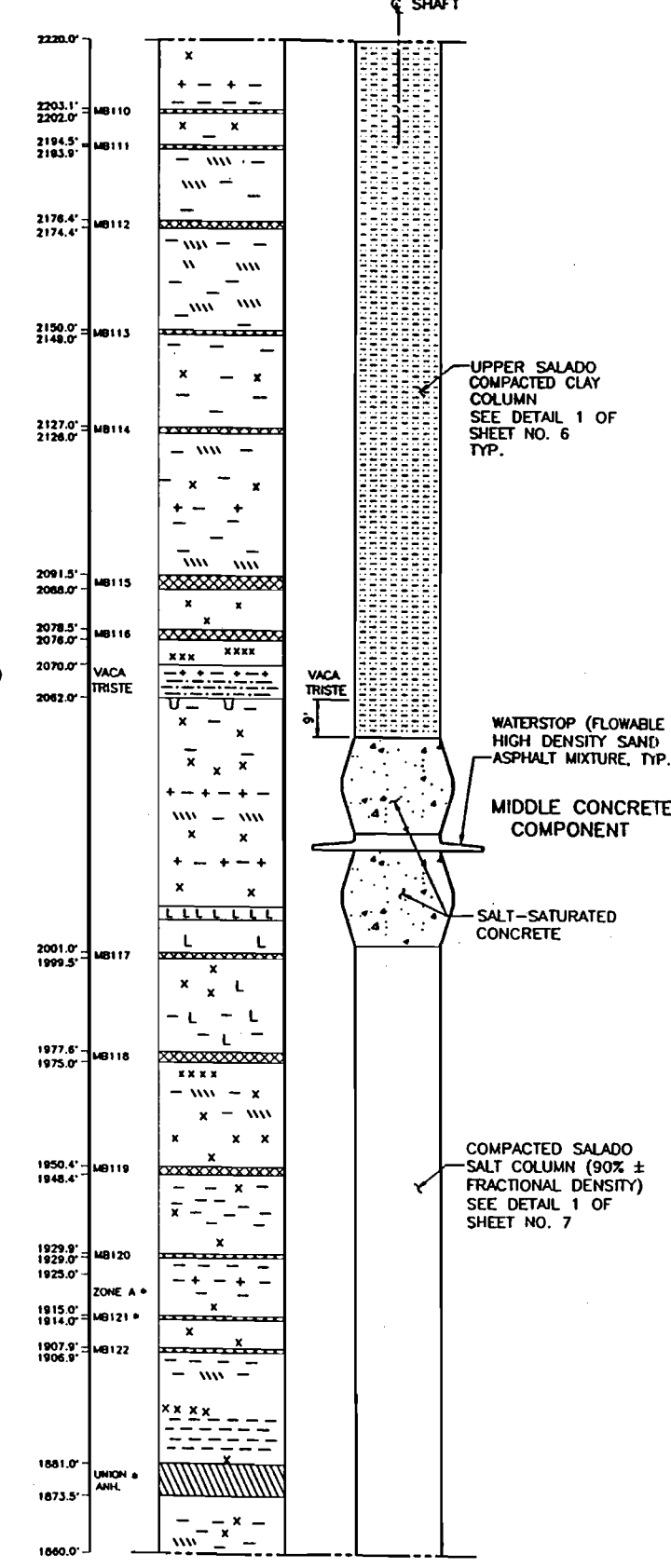
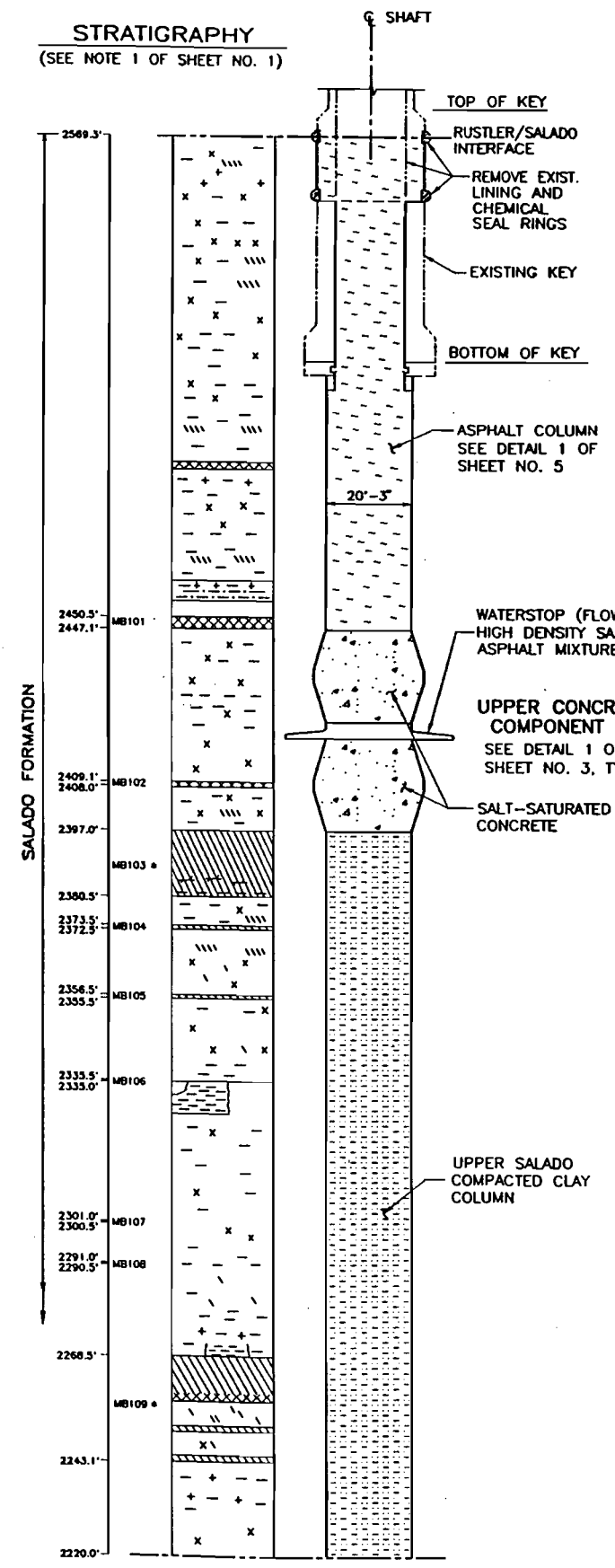

Figure 3-1.

STRATIGRAPHY
(SEE NOTE 1 OF SHEET NO. 1)



SALADO FORMATION SUBSYSTEM

REV.	DATE	DESCRIPTION	BY	CK.	APP.

SANDIA NATIONAL LABORATORIES		CONTRACT NO: AG-4909	
WIPP A/E SUPPORT		NAME	DATE
WIPP SHAFT SEALING SYSTEM		BY	10/11/93
SALADO FORMATION		CK.	10/11/93
AIR INTAKE SHAFT		APP.	10/11/93
STRATIGRAPHY AND SEALING		APP.	10/11/93
SUBSYSTEM PROFILE		APP.	10/11/93
PARSONS BRINCKERHOFF ENERGY SERVICES, INC	SCALE: SIZE B	SNL DWG. NO. 33-SNL-005	SHEET NO. 2 OF 10

Figure 3-2.

WIPP Sealing System Design Report

the Salado Formation, Marker Bed 103, was found to be moist during a July 1994 inspection. Moisture was observed in the uppermost section of the Dewey Lake Red Beds. For design purposes the following assumptions were used:

- migration of brine into the shaft occurs only at the locations identified in the AIS mapping report, and
 - MB 121, 124, and 129; Zones A through J; and the Union Anhydrite will not produce sufficient inflow to affect the consolidation of the compacted salt column.
- c. **Potential Pathways for Groundwater Infiltration.** Three potential pathways for groundwater infiltration are addressed by the sealing system design:
1. the material sealing the shaft,
 2. the interface between materials sealing the shaft and the surrounding rock, and
 3. the DRZ surrounding the shaft.
- d. **Design Approach.** Infiltration of groundwater is limited in the following ways:
- **Rustler Brines.** The shaft through the Rustler Formation will be sealed with compacted clay (Component 4 shown in Appendix B Dwg. 33-SNL-005, Sh. 9 of 10). This component is 235 ft long. The clay will be compacted using conventional methods. The existing shaft liner and shaft liner plate will be removed over the length of the Magenta and Culebra Members and over a portion of the aquitards above, between, and below these water bearing zones. Removal of the shaft liner in these regions permits the clay to seal the interface and interrupts pathways along or through the existing liner. The DRZ will be grouted in areas scheduled for liner removal before the existing liner and liner plate are removed to assure shaft wall stability. A concrete plug (Component 5 shown in Appendix B Dwg. 33-SNL-005, Sh. 8 of 10) will be installed below the compacted clay column to serve as a base for compaction of the clay. The concrete plug will be placed using standard construction methods, and the interface and DRZ will be grouted, if necessary.

Brines passing through the compacted clay column and concrete plug will be intercepted by the sealing system located at and just below the Rustler-Salado Contact zone.
 - **Rustler-Salado Interface Brines.** The shaft through the Rustler-Salado Contact and immediately below this contact will be filled with asphalt (Component 6 shown in Appendix B Dwg. 33-SNL-005, Sh. 5 of 10). To assure an interface seal through this zone, a portion of the existing shaft key (shown in Figure 3-2) will be removed. The asphalt column is 138 ft long. The asphalt is discussed in Section 4.5. The asphalt will provide a complete seal across the shaft and along the shaft interface. The shaft walls are unlined in the Salado Formation below the existing shaft key. Brines passing the asphalt column will be confined to the Salado DRZ.

The shaft will be sealed by the upper concrete component (Component 7 shown in Appendix B Dwg. 33-SNL-005, Sh. 3 of 10), which will be located immediately below the asphalt column. This component is 50 ft long and will be composed of upper and lower salt-saturated concrete plugs and an asphalt waterstop located at its midpoint. This component will effect a DRZ seal through two mechanisms:

 1. Healing of the DRZ. The DRZ in the salt surrounding the concrete plugs will heal as its stress state approaches that of undisturbed salt. By resisting inward creep of the salt, the concrete plugs will help reestablish a more uniform stress field. As the deviatoric

WIPP Sealing System Design Report

portion of the stress tensor diminishes and the mean stress increases, damaged salt will begin to heal. The concrete plugs will promote rapid healing of the DRZ.

2. Asphalt. The asphalt waterstop (shown in Figure 3-3 and Appendix B, Drawing 33-SNL-005, Sh. 3 of 10) will effect a seal in the DRZ by interrupting the flow path through the DRZ. The waterstop consists of a tapered slot cut 10 ft beyond the existing shaft wall and filled with a flowable high density sand-asphalt mixture. The slot is 2-ft high at the shaft wall and tapers to 1-ft high at its tip. The slot will be cut using equipment similar to that used in coal mining to undercut coal seams. Upon excavation of the slot a DRZ will form around the slot. The DRZ beyond the tip of the slot will heal shortly after the slot is filled with the flowable sand-asphalt mixture and the upper element of the concrete plug is placed.

The sand-asphalt mixture will be continuous across the shaft cross section, the interface, and the slot. Thus, this component will effectively seal all brine migration pathways. The upper element of this concrete component also provides a base for the asphalt column.

Any brine passing this seal from above will encounter the upper Salado compacted clay column (Component 8) and the middle concrete component (Component 9) before it reaches the compacted salt column (Component 10).

- Marker Beds 103 and 109 and the Vaca Triste. The shaft through this region will be sealed by the upper Salado compacted clay column (Component 8 shown in Appendix B Dwg. 33-SNL-005, Sh. 6 of 10) and the middle concrete component (Component 9 shown in Appendix B Dwg. 33-SNL-005, Sh. 3 of 10). The clay column will be 344 ft long. The middle concrete component is identical to the upper concrete component (Component 7).

MB 103 is the only unit within the Salado that is currently moist and therefore a potential source of groundwater within the Salado Formation. MB 109 and the Vaca Triste also intersect this component. These units were moist when the AIS was mapped, but did not appear moist when the shaft was inspected in 1994. The upper Salado compacted clay column will control inflow (if any) from these units. The upper Salado compacted clay column will be constructed in the same manner as the Rustler compacted clay column (Component 4). Because the shaft is not lined in the Salado, this component will seal both the shaft and the interface.

Moisture in this location migrating downward through the DRZ will be controlled by the middle concrete component (Component 9).

- Marker Beds 121, 124, and 129; Zones A through J, and the Union Anhydrite. The shaft through this region will be sealed by the compacted salt column (Component 10 shown in Appendix B Dwg. 33-SNL-005, Sh. 7 of 10). The compacted salt column will be constructed to obtain approximately 90 percent of the density of the intact WIPP salt. The salt column will be approximately 564 ft long.

Moisture was observed on the shaft wall at MB 121, 124, and 129; Zones A through J; and the Union Anhydrite when the shaft was mapped in 1989. Only salt encrustations were observed at these locations when the shaft was inspected in 1994. The absence of observable moisture indicates that either: (1) the moisture observed during shaft mapping resulted from limited area drainage of these units, which has ceased, or (2) the inflow is very low and evaporation prevents visible brine accumulation.

The salt column will offer limited resistance to brine migration immediately after

WIPP Sealing System Design Report

emplacement, and become less permeable as creep closure further compacts the salt and induces healing. Because the shaft is not lined in the Salado, this component will seal both the shaft and the interface. The compacted salt does not provide sufficient initial stiffness to bring about early healing of the DRZ.

- Groundwaters Between the Compacted Salt Column and the Repository. No sources of groundwater were identified below Zone J in the AIS. Groundwater reaching this region must pass the lower concrete component (Component 11 shown in Appendix B Dwg. 33-SNL-005, Sh. 3 of 10) and the lower Salado clay column (Component 12 shown in Appendix B Dwg. 33-SNL-005, Sh. 6 of 10) before gaining access to the repository horizon.

The lower concrete component is identical to the upper concrete component (Component 7). The lower concrete component provides a base for compaction of the compacted salt column.

The lower Salado clay column is approximately 94 ft long. Because the shaft is not lined in the Salado, this component will seal both the shaft and the interface.

- Shaft Station Monolith. The shaft station monolith (Component 13 shown in Appendix B Dwg. 33-SNL-005, Sh. 4 of 10) is the bottom component of the AIS sealing system. Its function is to stabilize the shaft station area. The shaft station monolith also provides a base for compaction of the lower clay column. The shaft station monolith will completely fill the station area. The interface between the monolith and the surrounding rock will be grouted.
- Sumps. The Waste Shaft and Salt Handling Shaft have sumps that extend 126 ft. and 114 ft., respectively, below the shaft station level. The sumps will be filled prior to construction of the shaft station monoliths in these shafts. Seepage has been observed at MB 139 and MB 140 in the sumps of the Waste Shaft and Salt Handling Shaft.

e. **Design Uncertainties.** The design uncertainties fall into three categories:

1. Uncertainties associated with present conditions in the Salado Formation, for example: the current availability of groundwater for infiltration and the extent and permeability of the DRZ in the various units and marker beds penetrated by the shaft.
2. Uncertainties associated with future conditions, for example: the future availability of groundwater for infiltration and changes in the extent and permeability of the DRZ with time.
3. Uncertainties associated with the long-term properties of certain sealing materials, for example: the useful life of the concrete components and the permeability of compacted crushed salt as a function of time.

These design uncertainties are addressed in the design by:

1. using all available space in the shafts for sealing;
2. using multiple components so poor performance of a single component will not lead to system failure;
3. using different materials so poor performance of one material does not lead to system failure.

The performance of the shaft sealing system is discussed in Section 5, Evaluation of Shaft Sealing System Design.

3.2.2 Brine Reaching the Regulatory Boundaries

- a. **Design Guidance.** The shaft sealing system shall limit the migration of radiological or other hazardous constituents from the repository horizon to the regulatory boundary during the 10,000-year regulatory period following closure.
- b. **Source of Brine.** After brine has migrated into the repository disposal areas, they are then modeled as the source of the brine for regulatory concerns.
- c. **Potential Pathways for Brine.** The pathways for brine forced upward from the repository level upward to the Culebra level (a vertical distance of approximately 1,370 ft) are the same as those for groundwater migration downward to the repository (i.e., the shaft, interface zone, and DRZ).
- d. **Design Approach.** Migration of brine is limited in the following ways:
 - **MB 138.** Brine entering the sealing system at and below MB 138 must pass through the lower clay column (Component 12). The lower clay column serves to limit migration of brine into the shaft and interface zone. The clay will be placed and compacted in a moist condition to assure good contact along the shaft walls and thus seal the interface zone. Brine migrating upward through this clay column, along the interface, and/or through the DRZ will be controlled by the lower concrete component (Component 11) during the first 100 years following closure.
 - **The Lower Concrete Component and Subsequent Components.** The lower concrete component and the remaining components between this component and the Culebra Member will limit the upward flow of brine in the same manner that they limit the downward flow of groundwater.
- e. **Design Uncertainties.** In addition to the design uncertainties identified in Section 3.3.1, uncertainties associated with the location of the entry point(s) and pressure history for brine into the sealing system have been identified.

This design uncertainty is addressed by placing sealing components with properties sufficient to resist fluid flow under WIPP conditions at and above MB 138.

3.2.3 Design Life

- a. **Design Guidance.** The shaft sealing system shall limit chemical and mechanical incompatibility of sealing materials with the seal environment.
- b. **Design Approach.** The design is composed of clay and salt components that will be stable throughout and beyond the 10,000-year regulatory period, asphalt components that may be stable throughout this period, and concrete components that are expected to degrade during this period. The design initially relies on the concrete, asphalt, and clay components to seal the shafts. After the first 100 years, the design relies on the clay and salt components to seal the shafts. The clay and salt shaft sealing system components are constructed of materials that are chemically compatible with the host rock and brine that may come in contact with them.
- c. **Design Uncertainties.** The permeability-density relationship used to predict the permeability of the compacted salt column as a function of time is a major uncertainty associated with meeting this design guidance item. Other, lesser uncertainties are

WIPP Sealing System Design Report

associated with the prediction of the useful life of the concrete and asphalt components. These design uncertainties have been addressed by (1) replacing the upper and lower compacted salt columns used in previous designs with compacted clay columns and (2) restricting the design (required) life of the concrete and asphalt components to 100 years.

3.2.4 Structural Adequacy

- a. **Design Guidance.** The shaft sealing system shall limit the possibility for structural failure of individual components of the sealing system.
- b. **Design Approach.** The structural adequacy of the components will be demonstrated using standard approaches and techniques. Structural analysis of the upper, middle, and lower concrete components was performed. The analysis showed that these components are primarily subjected to compressive loads. The analysis of these concrete components included analysis of the surrounding salt and predicted both the initial increase in the extent of the DRZ surrounding the concrete components and waterstops, and the subsequent healing of this DRZ. These concrete components are structurally adequate. Analyses have also been performed to predict the consolidation of the compacted salt column and clay columns. These analyses show that the compacted salt column will consolidate sufficiently during the 100 years following closure to form a low permeability seal. Healing of the DRZ surrounding the lower portion of the compacted salt column and the lower clay column will also be accomplished during the 100 years following closure. Healing of the upper portion of the DRZ surrounding the compacted salt column and the upper clay column may not be completed during the 100 years following closure. A discussion of the mechanical response of the sealing system is presented in Section 5.2.2.
- c. **Design Uncertainties.** The method used to address this design guidance item is the accepted approach where applicable codes and standards are not available. When uncertainties are identified by either design reviews or analyses, the design will be modified to reduce the uncertainties and to resolve issues of structural adequacy.

3.2.5 Subsidence and Accidental Entry

- a. **Design Guidance.** The shaft sealing system shall limit the possibility for subsidence of the ground surface in the vicinity of the shafts and accidental entry after sealing.
- b. **Design Approach.** The potential for subsidence is limited by complete filling of the shafts with low porosity materials. The potential for accidental entry is limited by installation of sealing system components whose removal would require construction activities similar to those used to sink the shaft.
- c. **Design Uncertainties.** None identified.

3.2.6 Development of New Construction Technologies and/or Materials

- a. **Design Guidance.** The shaft sealing system shall limit the need to develop new technologies or materials for construction of the shaft sealing system.
- b. **Design Approach.** The sealing system can be constructed using currently available technologies and materials. Obviously, adapting these available technologies for use at the WIPP will require development of construction procedures specific to the WIPP shafts. Current construction practices will be employed to:

- prepare the shaft walls prior to emplacement of sealing components. For example, the shaft walls will be cleaned, scaled back to sound surfaces, and all loose materials and shaft fittings will be removed prior to emplacement of sealing components in the Salado Formation;
 - grout the Rustler Formation and units above the Rustler to limit groundwater inflow and to assure shaft stability in those regions where the existing shaft liner will be removed prior to emplacing sealing materials;
 - grout the interface between concrete components and surrounding rock;
 - emplace asphalt and concrete and both compact clay and salt components.
- c. **Design Uncertainties.** The following design uncertainty has been identified: The asphalt column may be subject to intrusion of brine from the Rustler-Salado contact zone.

When asphalt was used to seal the annulus between old leaking shaft linings and new shaft linings in Germany, the hydraulic head in the asphalt column was maintained at a higher level than the hydraulic head in the surrounding formation to prevent the displacement of asphalt by groundwater. The hydraulic head in the Rustler-Salado Interface is higher than that in the asphalt column. The higher hydraulic head in the Rustler-Salado brine may initially result in brine intrusion into the asphalt column. However, the asphalt column is completely contained and the asphalt is not free to displace either vertically or horizontally. Therefore, the asphalt in the column would quickly reach an equilibrium pressure with the brine if brine intrusion occurs.

This design uncertainty will be addressed by assessing the potential effect of brine intrusion into the asphalt column. If this uncertainty cannot be satisfactorily resolved, the design will be revised to place the top of the asphalt column below the Rustler-Salado contact zone.

3.3 Design Alternatives

During the course of the development of this design, a number of alternatives were considered. In this section a number of these design alternatives are presented and discussed. During final design, detailed analyses of the system and its components may identify the need to incorporate some of the alternatives presented below. The alternatives are presented for the components starting at the surface and proceeding downward. In each case the current component is identified and then alternatives are identified which could be used in place of the current component.

Component 1. Clay or earthen fill is used for Component 1. Alternatives considered were:

- a. A concrete plug could be installed at the surface (e.g., in the AIS plenum) and the shaft could be filled below the plug. The plug design would be different for each shaft because each of the four shafts terminate differently at the surface.
- b. The plenum could be dismantled and a cap could be placed over the shaft collar or a plug could be placed in the shaft collar area. For the purpose of this discussion, a cap is slab of concrete capable of supporting a specified superimposed load, and a plug is a mass of concrete that fills the shaft and whose thickness is equal to or greater than the shaft diameter. The collars of the Waste Shaft and AIS are located approximately 20 ft below the

WIPP Sealing System Design Report

ground surface, while the collars of the Salt Handling Shaft and Exhaust Shaft are located at the surface.

- c. The clay or earthen fill could be replaced with compacted clay. This alternative would provide fill with higher density and lower permeability than that provided by clay or earthen fill.
- d. The existing concrete shaft liner could be removed. (Note: This alternative applies to all components located in the lined portion of the shaft.) This alternative would eliminate any compromise of the sealing system integrity by liner condition.

Component 2. A concrete plug is used for Component 2. Alternatives considered were:

- a. The existing shaft liner could be removed and the plug could be keyed into the surrounding rock. This alternative could be chosen at the time of shaft closure if the concrete shaft liner in this region is not sufficiently sound.
- b. Compacted clay or earthen fill could be used instead of concrete. This alternative would be used if a concrete cap or plug is placed at or near the ground surface.

Component 3. Clay or earthen fill is used for Component 3. Alternatives considered were:

- a. Compacted clay could be used instead of clay or earthen fill.
- b. Asphalt could be used instead of compacted clay or earthen fill. In Germany, asphalt has been used to seal leaking shaft liners (Valk, 1989; Stoss and Braum, 1983). New steel liners were installed in the German shafts and asphalt was placed in the void between the new liners and the leaking liners. The asphalt effectively sealed the leaking liner and permitted continued use of the shaft. The hydrostatic pressure in the asphalt must exceed that of the groundwater to effectively exclude groundwater from a shaft. The specific density of the asphalt fill and the height of the asphalt column would be chosen so that the hydrostatic pressure in the asphalt is higher than that in the water bearing units of the Rustler Formation and the Rustler-Salado contact zone.
- c. The existing concrete shaft liner could be removed. (See Component 1, Item d for discussion.)

Component 4. A compacted clay column is used for Component 4. Alternatives considered were:

- a. Asphalt could be used instead of a compacted clay. (See Component 3, Item b for discussion.)
- b. The existing concrete shaft liner could be removed. (See Component 1, Item d for discussion.)

Component 5. A freshwater concrete plug is used for Component 5. Alternatives considered were:

- a. If asphalt is used for Component 4, the freshwater concrete plug would be deleted and replaced by asphalt.
- b. The plug design could be modified so excavation is not required. The DRZ and interface would be grouted. The plug would develop resistance to displacement through mechanical

interlock with the surrounding rock. A longer plug may be required to assure adequate support, but there would be no need for excavation after removal of the existing shaft liner.

Component 6. An asphalt column is used for Component 6. Alternatives considered were:

- a. A compacted clay column could be used instead of the asphalt column. Compacted clay would provide a shaft fill with low permeability. This low permeability material would limit migration of groundwater from the Rustler-Salado Interface into the shaft. If Component 5 were retained and a sodium bentonite clay (for example, American Colloid Co., type MX-80) was emplaced in this location the clay would be completely contained. If brine entered this region local swelling of the bentonite would occur, developing pressures that would seal the interface between the clay and the surrounding rock and force the clay into fissures in the surrounding rock (Pusch, 1982).
- b. Pelletized dry bentonite could be placed in this region. The bentonite would be confined by the concrete plugs above and below the surrounding shaft wall. If brine entered this region local swelling of the bentonite would occur, sealing the region.
- c. The freshwater concrete plug (Component 5) could be relocated below the existing key (a movement of approximately 80 ft downward) and the Rustler compacted clay column (Component 4) extended through the key. This would reduce the length of the asphalt column (Component 6) from 138 ft to 38 ft. An asphalt column 38 ft long would also effectively seal the shaft and interface.

Component 7. A concrete plug with an asphalt waterstop is used for Component 7. Alternatives considered were:

- a. This component could be removed and replaced by either of the adjacent components. If a rigid plug is not emplaced, healing of the DRZ would take longer. The transition between the asphalt column and the clay column could be maintained by a concrete cap over the clay.
- b. The plug design could be modified so excavation is not required. The plug would develop resistance to displacement through mechanical interlock with the surrounding salt rock. A longer plug may be required to assure adequate support, but there would be no need for additional excavation.
- c. The waterstop could be eliminated or modified by not extending it into the surrounding salt rock. Upon installation, the asphalt provides assured sealing of the shaft cross section and interface. Sealing of the DRZ would be through creep closure and additional time would be required to achieve sealing of the DRZ.

Component 8. A compacted clay column is used for Component 8. The alternative considered was a compacted salt column.

Previous designs used a salt column in this region. The salt column was replaced by a clay column to (1) provide a medium that is less permeable during the 100 years following closure and (2) reduce the uncertainty associated with using the same material in each of the long-term seal components.

WIPP Sealing System Design Report

Component 9. A concrete plug with an asphalt waterstop is used for Component 9. The alternatives considered for this component are discussed under Component 7.

Component 10. A salt column is used for Component 10. Alternatives considered were:

- a. This component could be replaced with a compacted clay column. Initially the compacted clay column would have a permeability lower than a compacted salt column. However, during the 100 years following closure, the salt column permeability is reduced by creep closure and by the end of the period the permeability of the salt column would be less than that of the clay column.
- b. Compressed salt blocks or quarried salt blocks with salt-mortared joints could be used. The use of either of these materials would assure a salt column with a high value for its initial average density. Uncertainties exist with regard to the ability of the mortar joints to consolidate in a uniform manner.

Component 11. A concrete plug with an asphalt waterstop is used for Component 11. The alternatives considered for this component are discussed under Component 7.

Component 12. A compacted clay column is used for Component 12. The alternative for this component is discussed under Component 8.

Component 13. Shaft Station Monolith

This Component could be replaced by compacted crushed salt. Compacted crushed salt would be less rigid than the concrete and would therefore allow greater rock mass movement into the station area.

WIPP Sealing System Design Report

4.0 Materials

The basic design guidance for WIPP shaft seals is: prevent the shafts from becoming a pathway that compromises the repository's ability to meet performance objectives. Implicit in the fundamental design criteria is the assumption that if seal components are less permeable than the host rock, the sealing system will be adequate. This section discusses the materials used in the various seal components and explains why they are expected to function as intended. To return an open shaft to a state of low permeability, the seal design must account for three cross sectional elements:

1. the massive plug material that fills the opening,
2. the interface between the plug and the host rock, and
3. the disturbed rock around the shaft.

In this section pertinent material properties of the several seal elements are described. In general, the materials were selected for seal design elements because they are compatible with the stratigraphy, available, constructable, and have desired performance characteristics. The materials have been used widely or studied in detail to provide the basis for use within the WIPP sealing system. Material properties including permeability, strength, and mechanical constitutive response are given for each material as well as brief discussions of expected performance, construction techniques, longevity, and other characteristics relevant to the WIPP setting.

The terms "short-term" and "long-term" in this design report refer to the first 100 years after closure and from 100 to 10,000 years, respectively. The functional periods for some components such as concrete plugs, clay columns, and asphalt begin immediately upon construction. Each of these materials is expected not to degrade for very long periods; clay and asphalt are likely to be geochemically stable beyond the regulatory period of 10,000 years. Salt-saturated concrete within the Salado is likely to remain intact for hundreds of years, but guarantee of survival is more problematic. Nonetheless, design guidance for longevity of concrete, grout, and asphalt is for the first 100 years after closure. The crushed salt long-term component will become functional well within that period and will function in tandem with the clay column.

The seal materials include:

- Freshwater Portland cement concrete
- Salt-saturated concrete (Salado Mass Concrete)
- Compacted salt
- Compacted clay
- Asphalt
- Cementitious grout
- Clay or earthen fill.

Each material possesses particular favorable attributes. In the following discussion, all these materials except earthen fill, an optional material, will be examined with respect to their intended functions.

4.1 Freshwater Concrete

Concrete is perhaps the most common structural material used in the United States. For this seal design, freshwater concrete is differentiated from salt-saturated concrete. All good quality concrete possesses the highly desirable attributes of strength, ease of construction, rigidity, and a wide range of properties that can be tailored to specific functions. Concrete also has a very low permeability if it remains uncracked. These properties combine to make concrete the material of choice for hydraulic applications such as water storage tanks, water and sewer pipes, tunnel and shaft linings, massive dams, and countless other applications.

Use of concrete as a shaft seal component takes advantage of the exceptional performance of concrete in compressional states of stress. Reinforced concrete design is based on compressional volumes of concrete balanced by tensile stresses within reinforcing steel. Within the shaft setting, no tensile states of stress will exist, allowing use of unreinforced concrete. Vertical placement has the obvious advantage of no formwork and ready access during placement. In addition, concrete within the sealing system will not experience freeze-thaw cycles, which give rise to cracking in normal surface structural elements.

Freshwater concrete will be used within the non-Salado formations as a plug above the asphalt column straddling the Rustler/Salado contact (Component 5) and as a concrete plug near the top of the shaft (Component 2). These concrete plugs are designed to function as structural members possessing low permeability. Construction conditions are very favorable for a full face plug because hydration will be completed at 100% relative humidity. Preservation of water for hydration ensures a dense cementing paste. Well designed and properly cured mass concrete, as used in dams, typically will not achieve equilibrium pore pressure in its usual life (Neville, 1975), which is qualitative affirmation of extremely low permeability. The concrete elements of the seal design are expected to be structurally competent and much less permeable than the host rock.

4.2 Salt-Saturated Concrete

Salt-saturated concrete contains a sufficient amount of salt as an aggregate to saturate the water for hydration with respect to NaCl. Salt-saturated concrete will be used within the Salado Formation (Components 7, 9, 11, and 13) because freshwater concrete would dissolve part of the host rock. Dissolution would result in a poor bond or perhaps a more porous interface. Salt-saturated concrete, on the other hand, will bond tightly with the Salado host rock as it cures (Wakeley et al., 1993). Salt-saturated concrete has been used since the 1940s for completion of oil wells in salt domes and for decades in salt and potash mines. Use within these industries is quite wide but performance measures and properties of the salt-saturated concretes are not well published or documented. The salt-saturated concrete proposed for the WIPP sealing system (called Salado Mass Concrete, or SMC) is the result of several years of optimization and characterization of a preferred mix design. In addition, salt-saturated concrete has been used in experimental investigations at the WIPP. Therefore, the specification of SMC for WIPP seal components is well founded in experience and recent technical experimental results.

The Waterways Experiment Station (WES), operated by the US Army Corps of Engineers, has served the WIPP in concrete and grout development for about 20 years. Experience includes grout development and the grouting of a deep borehole in the Bell Canyon Formation (Gulick et al., 1980), a series of small-scale tests underground at the WIPP (Wakeley

et al., 1993; Finley and Tillerson, 1992) and recent optimization studies and mass concrete trial batches of SMC (Wakeley et al., 1995). In addition, the WES performed chemical degradation studies of cementitious materials including grouts, salt-saturated samples extracted from the WIPP horizon after several years in situ, and SMC. Some of the basic applicable results of these studies are given here.

Concrete permeability is an important design parameter. Studies show that the intrinsic permeability of SMC is extremely low, approaching $1 \times 10^{-21} \text{ m}^2$ when 100-mm-diameter samples are tested with nitrogen and permeability decreases as a function of time. This measurement corroborates the results of the Small Scale Seal Performance Tests (SSSPTs), which used another mixture of salt-saturated concrete. The salt-saturated concrete plugs in the SSSPTs were situated horizontally in a pillar and vertically in the WIPP horizon floor. They were subjected to stress and associated deformation, including floor heave, for about 9 years between performance tests. The SSSPT permeabilities measured on 1-m concrete plugs ranged from $4 \times 10^{-19} \text{ m}^2$ when initially tested in 1986 to less than $4 \times 10^{-19} \text{ m}^2$ when retested in 1995. The permeabilities measured during the SSSPT are system values that include transmissivity of the concrete, the interface, and any DRZ around the seal.

A smaller database of structural material properties exists for salt-saturated concrete than for the well-documented normal freshwater concrete. However, SMC concrete is expected to perform (based on laboratory measurements) as well or better than freshwater concrete in the Salado section of the shaft seals. Strength and deformational characteristics of SMC are equivalent to a very good quality freshwater concrete, and the stress state is compression. When batched in bulk volumes, SMC has a strength around 6000 psi (40 MPa) and a modulus of elasticity of over 5×10^6 psi (35 GPa) (Wakeley et al., 1995). Volume stability was found to be excellent: -0.0002 to -0.0004 after about a year of testing at 50% relative humidity, following ASTM standard procedures. It is expected that SMC used in situ will not shrink because curing conditions will eliminate moisture loss (i.e., concrete hydration will occur at 100% relative humidity).

The constitutive model for concrete is integral to analysis of the shaft sealing system. It is expected that a rigid inclusion such as a massive plug of SMC will exert a backstress against the host salt formation. In turn, the reestablished state of stress will tightly compress the interface and close fractures and promote healing within the DRZ. For modeling purposes, SMC is assigned an isothermal creep law fit to long-term creep test data. The elastic modulus is time (age) dependent, but reaches a constant value after about a year.

Another consideration with respect to the use of concrete within the Salado Formation is the potential of degradation if the concrete is exposed to replenished supplies of caustic brines. Salt-saturated concretes have been shown to resist brine attack better than ordinary Portland cement concrete (Wakeley et al., 1994). Based on the most representative field examples to date (Wakeley et al., 1993), degradation of salt-saturated concrete exposed to natural WIPP brines for over six years was found to be insignificant. After six years in situ, the bond between the salt-saturated concrete and the host rock was excellent and the phase assemblages were unaffected by the brine. The specified SMC for seal components in the Salado Formation is also more resistant to degradation by brine than is freshwater concrete. In addition, sources of brine within the Salado are limited and exposure of massive concrete structures to brine would be limited. Degradation of cementitious materials and concrete structures in the Salado portion of the shaft seal design is most unlikely.

4.3 Compacted Salt

Reconstituted salt comprises a major seal element (Component 10) located between MSL 2002 and 1440 ft (170 m in length). The concept of using crushed salt as a seal material originated in the 1950s when the National Academy of Sciences originally proposed storage of nuclear waste material in salt formations. It was assumed that the shafts could be filled with crushed salt, which would then consolidate naturally into a nearly impermeable seal by creep of the host rock. Chemical, physical, and mechanical compatibility was intrinsically assured. Laboratory testing over the last decade has shown that pulverized salt can be compressed into very dense blocks possessing very low permeability. Demonstrations of large-scale dynamic compaction and associated laboratory testing have established construction feasibility and measured several crucial performance parameters. Recent data establish that compacted crushed salt is a viable seal material.

Crushed salt will provide a seal that will function essentially forever once it has consolidated. This is demonstrated by establishing initial conditions, a constitutive response of the crushed salt as it consolidates, and a permeability/density function for the consolidating salt. Initial characteristics of dynamically compacted salt have now been measured (Ahrens and Hansen, 1995). A full-scale demonstration successfully compacted mine-run WIPP salt to a uniform density of 90% of intact salt. Compaction was relatively simple and involved dropping a 9000-kg weight into a structural steel test chamber containing mine-run salt. The demonstration did not attempt to optimize control parameters by grinding or sizing the salt and/or by optimizing the initial moisture content. The compacted mass (40 m^3) was permeability tested using a borehole gas flow tool. The mass was determined to have an average nitrogen permeability of $9 \times 10^{-14} \text{ m}^2$. This unique application of construction practices provides a baseline for predictions involving the shaft seal element comprising 170 m of compacted salt.

A significant effort has been made to establish a constitutive model for crushed salt because modeling of the sealing system is one means of evaluating performance through time. The model is used to predict performance of the salt after it is compacted in the open shaft. Initial technical evaluation of potential crushed salt constitutive models has been completed (Callahan et al., 1995). In this study, ten models with the potential to describe phenomenological and micromechanical processes of crushed salt were selected from a literature search. Three of the ten candidate models were screened for rigorous comparisons to a specially developed but somewhat limited database. The database contained hydrostatic consolidation tests, shear consolidation tests, and a combination of shear and hydrostatic tests. Based on the fitting statistics and the ability of the models to predict the test data, a model proposed by Spiers and coworkers (Spiers and Brzesowsky, 1993; Spiers and Schutjens, 1990; Spiers et al., 1989) was judged superior to other candidate models. The constitutive model work is fundamental to performance calculations of a crushed salt seal.

The constitutive model for consolidating crushed salt will be used in future calculations as part of seal design and system performance analysis. Conceptually, computer models will simulate the shaft after it has been filled with compacted salt. Constitutive relationships dictate how the host salt material creeps into the former shaft volume and how the crushed salt responds (i.e., by volume reduction and by change in the stress state). Volume reduction is accompanied by decreasing permeability within the salt component.

Other advancements in the basic understanding of crushed salt consolidation have occurred in the laboratory. This ongoing testing will develop a relationship between density and permeability as well as measure elastic constants. An initial test shows that permeability is reduced substantially and quickly at pressures ≤ 5 MPa. The experimental response of a sample of dynamically compacted salt is shown in Figure 4-1. A hydrostatic pressure of 2 MPa reduced permeability of the compacted salt sample by an order of magnitude. Further compression to 5 MPa reduced permeability to $3 \times 10^{-18} \text{ m}^2$ and increased sample density to approximately 0.97 of the density of intact salt. Using these data to formulate a preliminary permeability/density function, together with the appropriate constitutive relationship, allow an estimation of the permeability of the compacted salt column as a function of time.

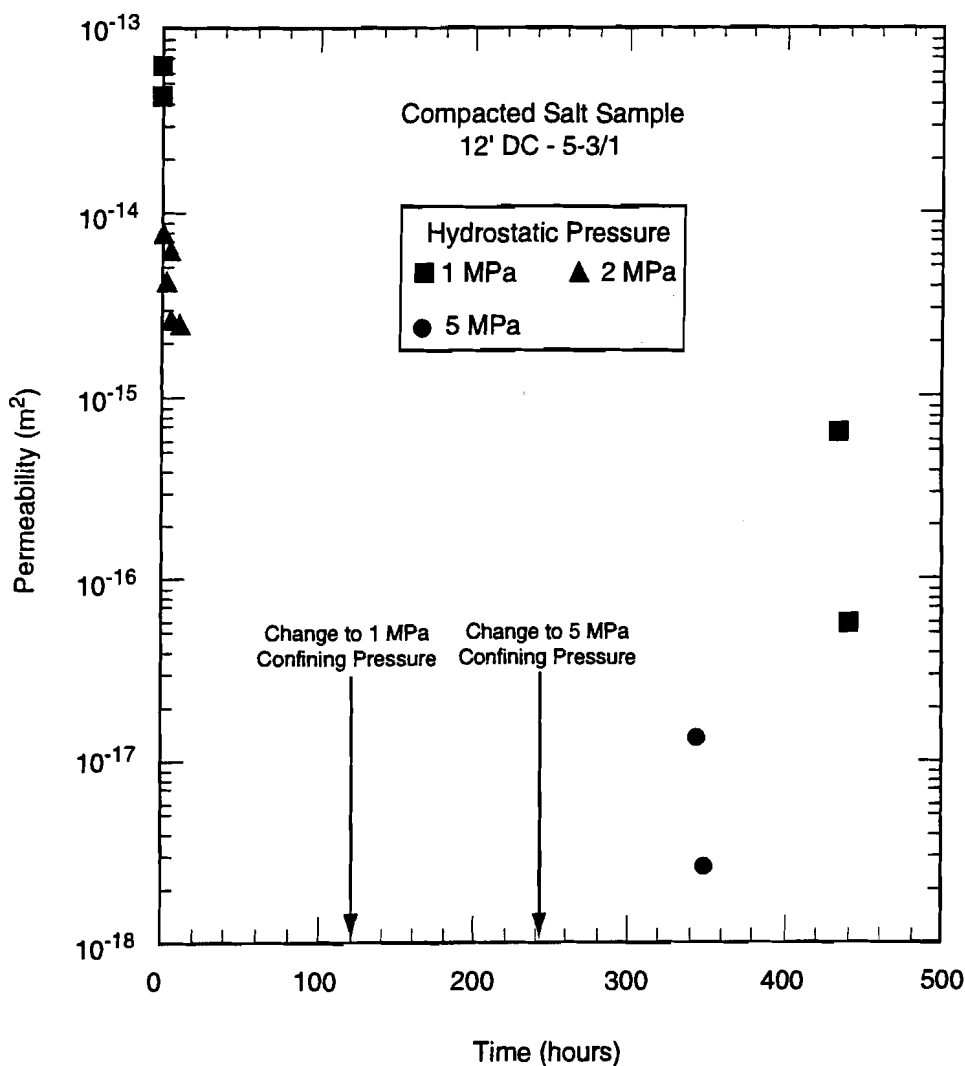

Figure 4-1. Permeability of compacted salt at low hydrostatic stresses.

Figure 4-2 plots the expected permeability range of the Salado salt column 100 years after placement at an initial density of 0.9 of intact salt. A range of values reflects differences between parameters for clean and argillaceous salt. This particular calculation includes the effect of backstress on the crushed salt. Under these modeling assumptions it is shown that 70 m of the salt column is tighter than $1 \times 10^{-18} \text{ m}^2$ at 100 years. These magnitudes of permeability and effective lengths of salt column are consistent with those used for design evaluation (Appendix D). Tests currently being conducted will generate additional permeability data with stress path deviation to characterize elastic properties as a function of density. These additional calculations will refine the information plotted in Figure 4-2.

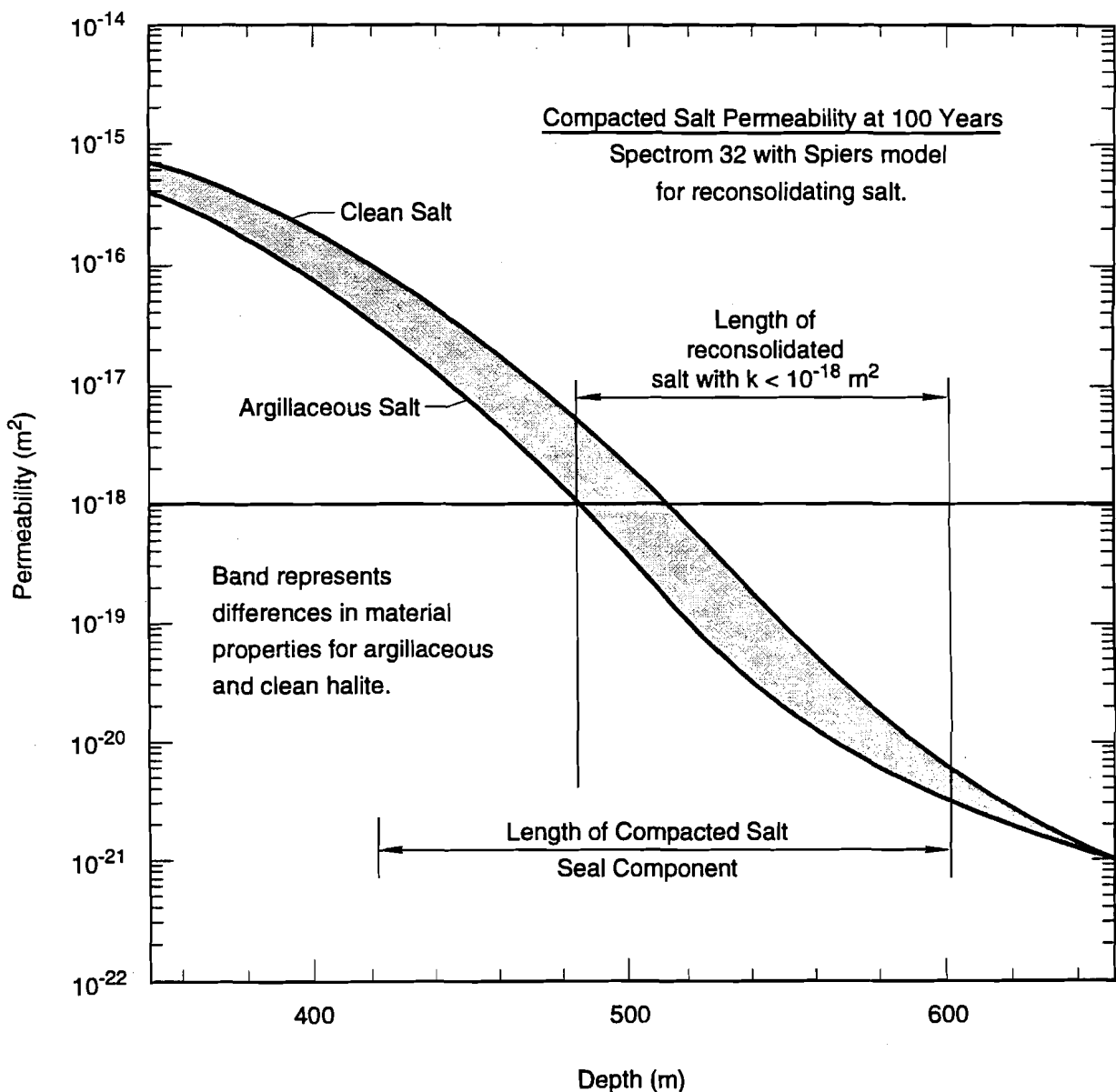

Figure 4-2. Estimated permeability of the Salado salt column at 100 years.

4.4 Compacted Clay

Clay comprises major components of the shaft sealing system at five locations: (1) near the surface between 3410 ft and 3353 ft MSL, (2) in the Dewey Lake between 3313 ft and 2840 ft MSL, (3) between 2840 ft and 2605 ft MSL in the Rustler, (4) between 2397 ft and 2053 ft MSL in the Salado Formation (Component 8), and (5) near the bottom of the shaft between 1340 ft and 1296 ft MSL (Component 12). Bentonite clay is chosen here because of its overwhelmingly positive sealing characteristics. Relative to other clay minerals, such as illite or kaolinite, bentonite is perhaps two orders of magnitude less permeable (see Section 4.5). Bentonite is widely used as a sealing component in a variety of geotechnical applications. In particular, bentonite is considered a primary sealing material in several international nuclear waste repository programs. Studies on sealing with bentonite have been conducted in Canada, England, France, Germany, Sweden, Switzerland, and the United States.

Bentonite is an excellent seal material because of its many positive attributes for the WIPP environment: low permeability, swelling potential, strength and mechanical properties, compatibility and longevity, as well as reasonable construction requirements. Generation of significant gas pressure (as much as 2 MPa) is not expected for the first several hundred years after waste emplacement. Nonetheless, the proposed design will quickly and effectively minimize gas migration. Compacted bentonite is an effective gas barrier because of a threshold pressure that is required to displace water in the larger pores. This performance characteristic coupled with the low permeability of the lower concrete component is sufficient to protect the consolidating salt column from gases generated by the repository.

In situ tests of bentonite at the WIPP, involving about a cubic meter of material, corroborate the expected sealing function. Blocks of bentonite were stacked in vertical and horizontal 1-m-diameter boreholes. Microdarcy permeability ($1 \times 10^{-18} \text{ m}^2$) was measured after about two months of brine testing. Subsequently, permeability continued to decrease. After 6 years of brine flow testing at 0.67 MPa (100 psi), no brine has been observed to have passed through the 1-m seal. A test of threshold pressure using gas and the same bentonite seal was completed in 1995. A pressure over 500 psi ($>3 \text{ MPa}$) was required to initiate flow.

In addition to its inherent low permeability, clay can also be expected to resist creep of the host Salado Formation salt into the shaft. By resisting inward creep of the salt, the clay component will help reestablish a more uniform stress field. As the deviatoric portion of the stress tensor diminishes and the mean stress increases, damaged salt will begin to heal. The clay component near the bottom of the shaft will promote rapid healing of the DRZ. Compaction data from Lambe and Whitman (1969) was used to develop a density-dependent bulk modulus. When this material model is used to represent clay placed in the lower Salado compacted clay column, the DRZ over the length of the clay component is eliminated in less than 25 years after construction. Figure 4-3 is a plot of DRZ healing as a function of time for the shaft column filled with compacted clay. Based on the most recent creep and fracture finite-element model (Chan et al., 1995), if 50 years are assumed to elapse before construction of the shaft seals, the potential exists for a DRZ to develop up to 0.8 shaft radii into the rock mass. Rigidity of the clay is sufficient to heal the DRZ in salt between 10 and 25 years after construction of the seal component. Any stiff seal material, such as concrete, would likewise heal a DRZ in salt within the same period of time.

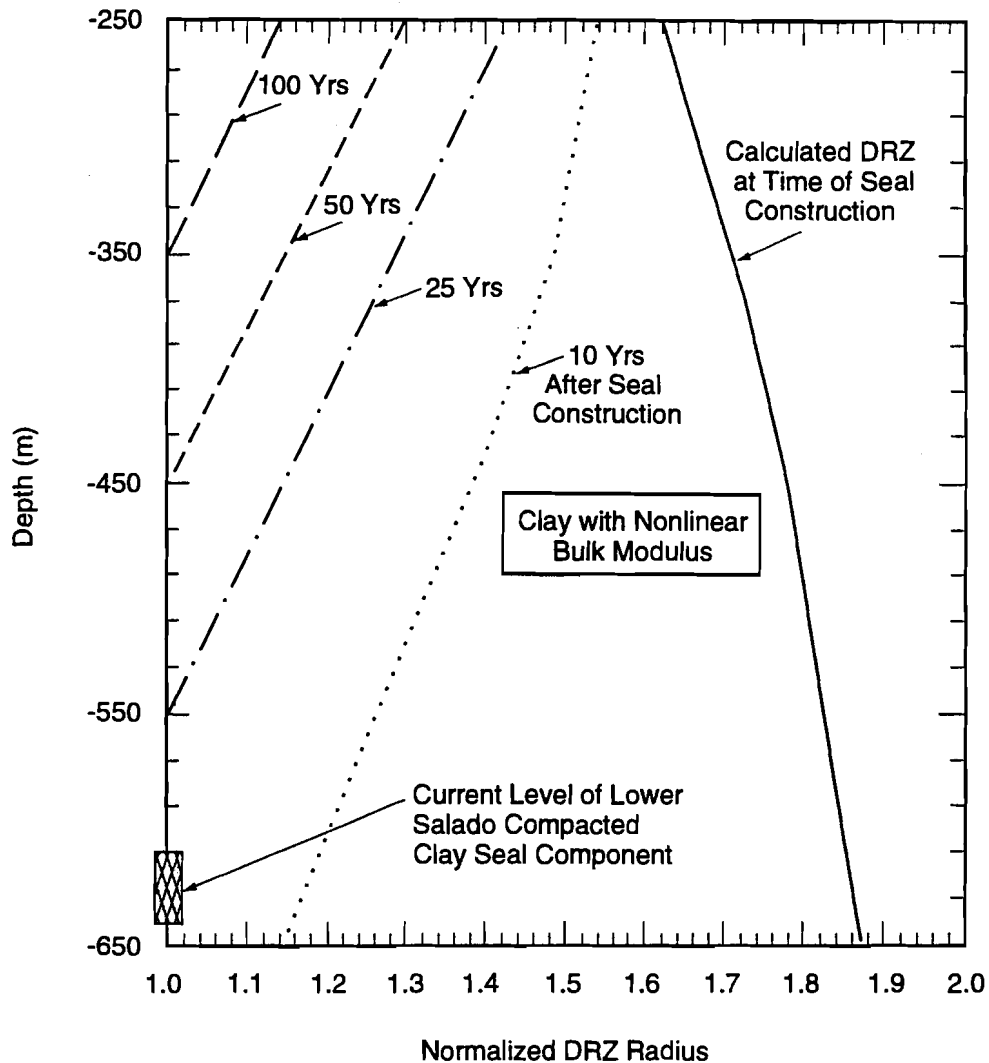

TRI-6121-315-1

Figure 4-3. Extent of DRZ at various depths within the shaft.

Elsewhere in the seal column, clay can be expected to possess equally low permeability. Within the Rustler, the clay seal component will be less permeable than most of the surrounding rock no matter which clay mineralogy is selected. The anhydrite layers in the Rustler have very low permeabilities. The overall permeability of the Rustler is about 1×10^{-14} to 10^{-15} m^2 (Beauheim, 1987). As illustrated in Figure 4-4, clays can readily achieve permeabilities lower than 10^{-14} to 10^{-15} m^2 . The compacted clay component within the upper Salado will inhibit fluid flow just like other clay components would, but the DRZ within the salt would not heal as quickly as around components at greater depth because of smaller stress magnitudes. Bentonite and other clays act as aquitards in the geologic setting. This means clay remains relatively impermeable over time periods far exceeding the regulatory period for the WIPP.

4.5 Asphalt

An asphalt column is proposed as an extensive seal component from MSL 2585 to 2447 ft (Component 6). In addition, asphalt is proposed to act as a waterstop between concrete members at three locations within the Salado Formation. Asphalt or bitumen is commonly used in Europe as a seal component around concrete shaft liners and is considered a viable seal material for radioactive waste programs in England and Germany. Asphalt has been considered as an alternative seal material within the WIPP seals program for several years. Asphalt has been added to the present shaft seal design to increase redundancy and confidence in performance of the system and to add assurance that transport of brine down the sealed shaft is precluded.

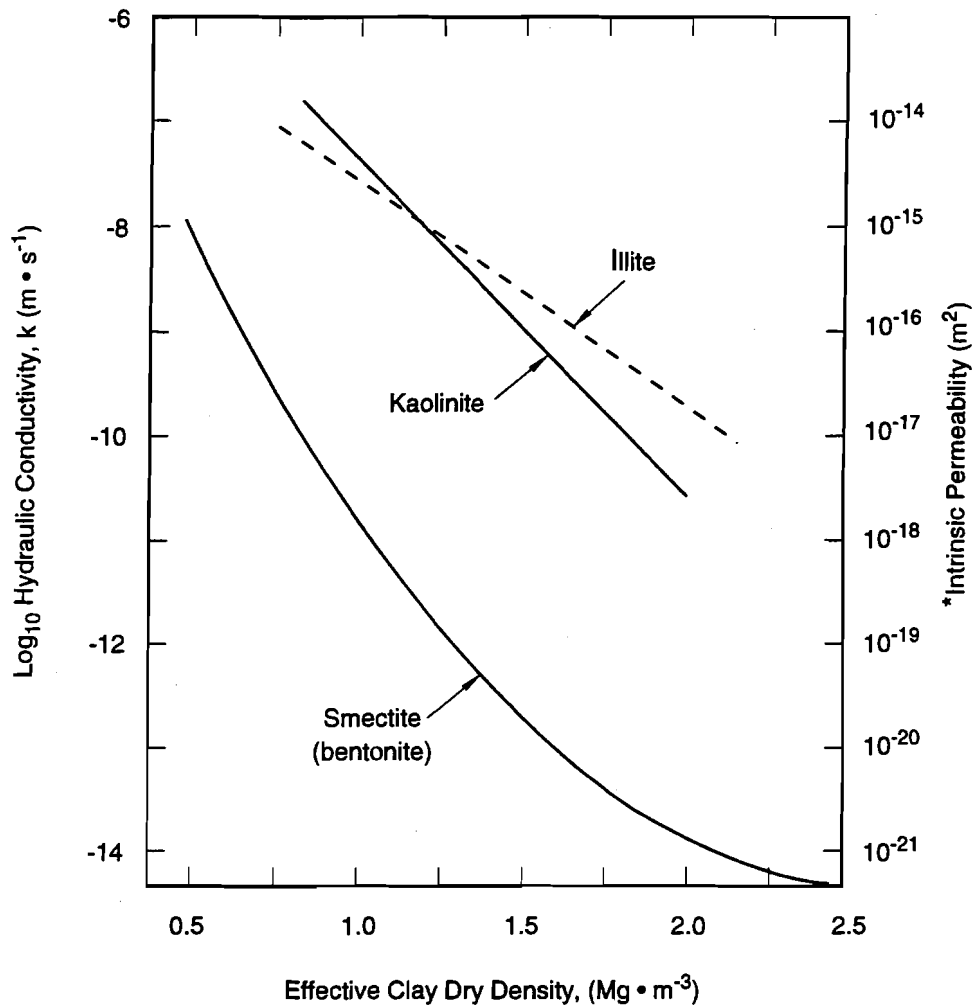

* Intrinsic permeability based on a fluid density of 1000 Kg/m³ and a fluid viscosity of 1 x 10⁻³ Pa · s.

TRI-6121-304-1

Figure 4-4. Relationship between hydraulic conductivity, intrinsic permeability, and effective clay dry density for selected clay minerals (from Johnson et al., 1994).

Technical specifications for asphaltic components have not yet been completed, but considerations center on use of an asphalt mastic mix (AMM) in contrast to hot-mix asphalt concrete or liquid asphalt options. AMMs for hydraulic structures are mixtures of asphalt, sand, and mineral filler. The asphalt content of AMM is much higher than that used in typical hot-mix asphalt concretes such as pavements.

High asphalt contents (10-20% by weight) and fine, well graded aggregate comprising sand and mineral fillers are used to minimize interconnected porosity. Equipment available from vertical barrier-construction and well-drilling technologies can be adopted to build an AMM seal successfully under WIPP construction conditions. In place densities should approach 98% of maximum theoretical density with a permeability of $1 \times 10^{-21} \text{ m}^2$.

The viscosity of the AMM is an important physical property of the design specification. The AMM must be pourable at application temperatures, able to penetrate into voids or fractures, and viscous enough to control long-term flow. Hydrated lime is a possible additive to decrease moisture susceptibility and to act as an antimicrobial agent.

For calculations, asphalt in the shaft is assumed to behave elastically. Elastic properties of asphalt are sensitive to temperature, which is held constant at 27° C. Elastic properties for current analysis are taken from Yoder and Witzak (1975).

4.6 Cementitious Grout

Grouting is an option for sealing interfaces and the DRZs of nonsalt units within the Salado Formation. Portland cement is the most widely used grouting material because of its low cost, availability, engineering properties, and long history of use. Neat (without aggregate) cement grout consists of Portland cement and water, but admixtures are commonly employed to alter its characteristics. There are five types of Portland cement, and any may be used for grout. The choice of cement type depends on the application. Grout can be formulated to attain certain specific properties, such as low heat of hydration, chemical resistance, and high early strength.

Within the shaft sealing system, grout is proposed to seal interfaces and penetrate microfractures within the DRZ of nonsalt lithologies or other zones where microfractures are not expected to heal naturally. All cementitious grouts contain particles, so the maximum particle dimension should be no larger than one-third of the aperture of the microcracks. A cementitious grout has been developed at Sandia National Laboratories (Ahrens, 1995) and demonstrated to be suited for producing, mixing, and injecting at the WIPP. The grout, called "ultrafine," has 90% of its particles smaller than 6 microns. Ultrafine consists of Type V sulfate-resistant Portland cement, a pozzolan of amorphous silica, and superplasticizer. Pozzolan replaces much of the Portland cement, reducing heat of hydration. Ultrafine is the specified grout for the sealing system.

4.7 Materials Summary

A recap of the materials used in the seal design, the potential zones they treat, and their performance period are given in Table 4-1. The primary design function expected of the materials is to prevent the sealed shaft and the surrounding DRZ from becoming a preferred pathway for the transmission of fluids; therefore, Table 4-2 summarizes the permeabilities of the components.

WIPP Sealing System Design Report

Table 4-1. Seal Materials for the Salado Formation

Material	Short-term Period			Long-term Period		
	Cross Section	Interface	DRZ	Cross Section	Interface	DRZ
Concrete	X	X	X			X
Compacted Salt				X	X	X
Compacted Clay	X	X		X	X	X
Asphalt Column	X	X		X	X	
Asphalt Water Stop	X	X	X	X	X	X

Table 4-2. Material Permeabilities

Seal Material	Permeability (m ²)
Freshwater/Salt-Saturated Concrete	
0 to 100 years	5.0×10^{-19}
100 to 10,000 years	1.0×10^{-14}
Consolidated Salt	
0 years	9.0×10^{-14}
100 years	1.0×10^{-18}
100 to 10,000 years	$<1.0 \times 10^{-18}$
Clay/Compacted Clay	1.0×10^{-18}
Asphalt	1.0×10^{-21}
Cementitious Grout	3.0×10^{-17}
Earthen Fill	1.0×10^{-14}
Salado Halite	1.0×10^{-21}
Salado DRZ	1.0×10^{-16} to 1.0×10^{-21}

WIPP Sealing System Design Report

5.0 Evaluation of Shaft Sealing System Design

In this section, the performance of the shaft sealing system is compared to the design guidance presented in Section 2. The design is evaluated with respect to this comparison and also with respect to the functions of the shaft sealing system. The performance expectations for the shaft sealing system are discussed, as well as analyses conducted to evaluate the sealing system. This section presents a summary of the analyses which demonstrate that the sealing system meets the design guidance and performance expectations. Further evaluation of the sealing system with respect to fluid flow is currently under way using two-phase flow models. These analyses will be available for the compliance certification package.

In general, the sealing system is divided into two functional regions: the upper seal system and the lower seal system. The compacted salt column comprises a member of the lower seal system. Performance expectations of the upper seal system are to separate water bearing zones and to retard the downward migration of brine into the compacted salt column. Design performance of the lower seal system is divided into short-term and long-term functions. In the short-term, the lower concrete component (Component 11) and the lower Salado compacted clay column (Component 12) are expected to retard the flow of brine and gas from the repository into the compacted salt column. The compacted salt column will consolidate during the short-term and will act as a permanent barrier to the flow of brine or gas through the sealing system to the regulatory boundary during the long-term.

There are two major long-term seal materials for the WIPP shaft sealing system: the upper and lower clay columns (Components 8 and 12), and the compacted salt column (Component 10). Redundancy of function is incorporated into the system to assure the salt is adequately protected while it consolidates. From above, asphalt, concrete, and clay protect the salt column. From below, clay and concrete with an asphalt waterstop protect the salt. After the salt column consolidates, the clay and perhaps the asphalt will also continue to provide long-term performance redundancy.

5.1 Structural Performance

Analyses were performed to evaluate structural considerations for seal components in the Salado formation. Components comprising the WIPP sealing system will be subjected to favorable, compressive stress conditions. Uniform compressive stresses will decrease void space, tighten any interfaces, heal microfractures in salt, and reduce permeability of the entire seal system. At this point in the design process, structural properties are available for materials that will be used for evaluating the configuration and locations of each sealing component. The materials are discussed in Section 4.0, and the configurations are shown in Drawing 33-SNL-005, Sheets 1 through 10 (Appendix B). During the next phase of design, additional component analyses will be conducted to verify that they are adequate to withstand the forces expected from rock creep and hydraulic pressure. Analyses used in the design of components are discussed below.

The principal structural considerations associated with the compacted salt column are:

- the rate at which the compacted salt consolidates, and
- the ability of the consolidating salt to create a compressive load (backstress) on the shaft walls.

Both the consolidation rate and the backstress are dependent on the initial density of the compacted salt, depth of emplacement, and elapsed time after emplacement. As the density of the emplaced salt increases, the consolidation rate decreases and backstress increases. Increase in backstress is desirable because it promotes healing of the DRZ. Analysis showed that compacted salt emplaced at a density approaching 90 percent of intact salt would consolidate sufficiently to meet the quantitative design guidance for long-term seals. Examples of results from these analyses are presented in Appendix D and Section 4.

The principal structural consideration associated with the clay and asphalt components was the determination of the time necessary to heal a portion of the DRZ adjacent to the components. Figure 4-3 shows the extent of the DRZ as a function of depth and time when compacted clay is used as the sealing material. This particular analysis demonstrates that the DRZ is healed near the lower Salado clay component in less than 25 years. Similar rapid healing of the DRZ is expected for other rigid or relatively incompressible seal materials used in this design.

The principal structural considerations associated with the concrete components are:

- determination of the effects that notches excavated in the shaft wall have on DRZ,
- time (after installation) required to heal the DRZ around the waterstop,
- time (after installation) required to heal the DRZ around the concrete plugs, and
- ability of the concrete plugs and host rock to accommodate shear and bearing stress imposed by overlying fill materials and/or pressure that may be imposed by brine or gas.

These analyses were used to choose the sizes and shapes of the asphalt waterstop and the concrete plugs. The analyses also identified stress levels in the concrete plugs as a function of time.

5.2 Fluid Flow Evaluation

Qualitative guidance on the performance of the system indicates the need to limit brine flow down the shaft and limit brine or gas flow up the shaft. Both considerations have impact on the time necessary for consolidation of the compacted salt column (Component 10). This component is therefore used to evaluate the performance of the remaining components during the first 100 years. If the compacted salt column is protected from the flow of brine from above, then the repository will be isolated from that brine flow as well. Similarly, the consolidating salt must be protected from upward flow of brine or gas during that period. Limitation of fluid flow into the salt column inherently limits upward migration of brine or gas through those components that overlie the salt column and, consequently, to the regulatory boundary. Quantitative design guidance (Section 2) has provided estimates of seal properties required to limit the flow of fluids in the shaft sealing system, and Section 3 gives specific purposes of each design component.

A comparative analysis of flow potential is described in Appendix D. This analysis compares flow potential, as defined by hydraulic conductance for both the cross-sectional seal material and the expected disturbed rock zone (DRZ), to the quantitative design guidance. Details of the single-phase fluid flow analysis are described in section D.3 along with the analysis assumptions and the associated parameters. Tables D-1 and D-2 provide both the absolute and normalized hydraulic conductance values for the lower and upper seal system

components. Results in these tables allow an evaluation of the degree to which the sealing system meets the design guidance; the quantitative guidance is met if the sum of the normalized conductances for the components of a system exceed unity. The degree to which an individual component can meet the quantitative system requirement for that function by itself can also be evaluated. Readers should not necessarily draw the conclusion (based solely on a low normalized conductance) that a particular component/material is ineffective because component length and the extent of the DRZ are both included in the conductance values, as discussed in Appendix D.

5.2.1 Upper Seal System

This section summarizes an evaluation of the upper seal system as compared to the design guidance for flow. A scoping analysis will also be provided in this section on the expected brine flow into the compacted salt column from the Rustler formation.

Both the qualitative and the quantitative design guidance for the upper seal system given in Section 2 are met at all times. Additionally, system confidence is very high because, at emplacement, two components meet the design guidance for the system and, within 50 years after emplacement, all components meet the design guidance by themselves. The total normalized conductance for the upper seal system is greater than 4.0 immediately after installation and improves with time because of DRZ healing. This result is not surprising because extensive lengths of very low permeability materials are used, and the permeability of the DRZ is not much higher than the needed system permeability. The upper seal system therefore meets the design guidance and offers redundancy for the regulatory period.

The following discussion presents a conservative approximation of brine flow down to the compacted salt column. Using Darcy's Law and assuming that the shaft above the upper compacted clay (Component 8) is filled with water, the predicted flow is:

$$\text{flow} = (\text{conductance}) \times (\text{height of water column}) \quad (5-1)$$

The conductance for the clay seal material and surrounding DRZ is, from Table D-1, time-dependent for the first 100 years. Using the appropriate conductance at times 0, 10, and 50 years, a conservative calculation predicts a maximum of 30 m³ of brine can flow through the clay column in 100 years (it is assumed that the conductance remains constant for the period between 50 and 100 years). The initial pore volume of the compacted salt column is approximately 500 m³. As the salt consolidates, the pore volume is reduced. Brine saturation of the available pore volume will impede the consolidation rate. From Figure D-3 it is seen that, at 100 years, the fractional density at the midpoint of the salt column is approximately 95% of the density of intact halite. Based on this figure, a first-order approximation of the available pore volume at 100 years is 150 m³. This pore volume is significantly greater than 30 m³. This quantity of brine is not sufficient to impede consolidation of the salt column. This analysis takes no credit for seal components that overlie the clay seal material or the concrete component with an asphalt waterstop, which underlies the compacted clay. Therefore, it can be concluded that the upper seal system will meet the performance expectation of limitation of brine flow down into the salt column.

5.2.2 Lower Seal System

This section summarizes an evaluation of the lower seal system as compared to the design guidance for gas flow. Table D-1 identifies the effective conductance of various components that can limit gas or brine flow. With the exception of initial emplacement ($t = 0$), the system is effective at all times in meeting the quantitative design guidance for this system. The lower seal components comprising concrete with a water stop (Component 11) and compacted clay (Component 12) do not need to immediately meet the quantitative design guidance because gas pressure is expected to be minimal in the first few years after repository closure.

The lower compacted clay column will be capable of providing an effective gas seal. Two-phase flow dynamics are not considered in these calculations. The compacted clay column will be moist when emplaced. The current design specifies a gas threshold pressure of 2 MPa. Three physical characteristics of the sealing system control the flow of gas. These are the difference in fluid pore pressures across the seal (driving force), the gas threshold pressure of the seal, and the relative permeability of the seal (gas permeability). Because the clay column will be emplaced at a brine saturation approaching unity, the gas permeability of the clay seal will approach zero and at most will be one-tenth or one-hundredth of the intrinsic permeability of the clay (intrinsic permeability is used in the analyses presented in Appendix D). Substituting an intrinsic permeability one order of magnitude smaller than the one used for the clay column reveals that the normalized hydraulic conductance for the clay column and DRZ would be greater than 1 and would meet the guidance. For the seal to be an ineffective gas barrier at early times, the gas pressures at the base of the shaft would have to increase to pressures exceeding the pore pressure in the seal plus the gas threshold pressure of the seal material. Gas threshold pressure can be related to permeability (Davies, 1991). For a seal with a permeability of $1 \times 10^{-18} \text{ m}^2$, the gas threshold pressure could be several MPa. Therefore, even though the single-phase calculations show that the lower seal does not meet the quantitative design guidance at closure, two-phase flow dynamics will result in an effective gas seal.

6.0 Conclusions

The WIPP shaft sealing system design documented in this report is an effective, implementable design concept. The design concepts were developed through an interactive process involving technical specialists in the design and construction of underground facilities, materials behavior, rock mechanics analysis, and fluid flow analysis. The design uses (1) a variety of common materials that have very low permeability, (2) demonstrated technologies for construction processes, (3) multiple components to perform each intended function, and (4) the entire length of the shafts to effect a sealing system. In addition, the design incorporates recent developments related to:

- successful demonstrations of compaction technology for salt compaction;
- attainment of high densities and accompanying low permeabilities in consolidating crushed salt;
- development of a constitutive model for crushed salt consolidation;
- design guidance that better quantify performance goals for, and the importance of, seal permeability;
- design guidance on functional requirements for seal components;
- development of improved capabilities for simulating WIPP salt creep behavior and potential DRZ development and healing;
- successful retesting (~10 years after emplacement) of WIPP small-scale concrete seal performance, which shows permeability $\sim 10^{-20} \text{ m}^2$; and
- additional information from WIPP studies, international studies, and construction experience related to the very low permeabilities of salt-saturated concrete, asphalt, and clay.

The designers have provided a shaft sealing system that is an effective barrier to brine and gas flow. For the permanent or long-term seal that resists both gas and brine flow, robustness is achieved by providing more than 500 ft of a highly-compacted crushed salt barrier in series with more than 400 ft of clay barriers. The design retards gas flow in the short-term using a redundant combination of a rigid concrete barrier (enhanced by an asphalt waterstop included as an additional DRZ barrier) and a compacted clay barrier approximately 100 ft in length. Finally, short-term brine flow down the shaft is limited by a clay barrier within the Rustler Formation and by a combined length of more than 500 ft of asphalt, clay, and concrete barriers within the Salado Formation. These design concepts form the basis for No-Migration Variance Petition modeling, initiation of the detailed design development, and evaluations that will be completed in 1996 for incorporation, as appropriate, into the Compliance Certification Application.

WIPP Sealing System Design Report

References

- Ahrens, E.H. 1995 (In press). *Data Report on the Small-Scale Seal Performance Tests, Series F Grouting Experiment in Room L3*. SAND93-1000, Sandia National Laboratories, Albuquerque, NM 87185.
- Ahrens, E.H., and F.D. Hansen. 1995 (In press). *Large-Scale Dynamic Compaction Demonstration Using WIPP Salt: Fielding and Preliminary Results*. SAND95-1941. Albuquerque, NM: Sandia National Laboratories.
- Beauheim, R.L. 1987. *Interpretations of Single-Well Hydraulic Tests Conducted At and Near the Waste Isolation Pilot Plant (WIPP) Site, 1983-1987*. SAND87-0039. Albuquerque, NM: Sandia National Laboratories.
- Beauheim, R.L., and R.M. Holt. 1990. "Hydrogeology of the WIPP Site," *Geological and Hydrological Studies of Evaporites in the Northern Delaware Basin, Field Trip #14 Guidebook, Geological Society of America 1990 Annual Meeting, Dallas, TX, October 29-November 1, 1990*. SAND90-2035J. Dallas, TX: Dallas Geological Society. 131-179.
- Brodsky, N.S. 1994. *Hydrostatic and Shear Consolidation Tests With Permeability Measurements on Waste Isolation Pilot Plant Crushed Salt*. SAND93-7058. Albuquerque, NM: Sandia National Laboratories.
- Callahan, G.D., M.C. Loken, L.L. Van Sambeek, R. Chen, J.D. Neiland, and F.D. Hansen. 1995 (In press). *Evaluation of Potential Crushed Salt Constitutive Models*. Albuquerque, NM: Sandia National Laboratories.
- Chan, K.S., S.R. Bodner, A.F. Fossum, and D.E. Munson. 1995. "Constitutive Representation of Damage Healing in WIPP Salt," *Rock Mechanics, Proceedings of the 35th U.S. Symposium, University of Nevada, Reno, NV, June 5-7, 1995*. Eds. J.J.K. Daemen and R.A. Schultze. Brookfield, VT: A.A. Balkema. 485-490.
- Davies, P.B. 1991. *Evaluation of the Role of Threshold Pressure in Controlling flow of Waste-Generated Gas into Bedded Salt at the Waste Isolation Pilot Plant*. SAND90-3246. Albuquerque, NM: Sandia National Laboratories.
- Deal, D.E., R.J. Abitz, D.S. Belski, J.B. Case, M.E. Crawley, C.A. Givens, P.P. J. Lipponer, D.J. Milligan, J. Myers, D.W. Powers, and M.A. Valdivia. 1995. *Brine Sampling and Evaluation Program 1992-1993 Report and Summary of BSEP Data Since 1982*. DOE-WIPP 94-011. Carlsbad, NM: U.S. Department of Energy, Waste Isolation Pilot Plant.
- Finley, R.E., and J.R. Tillerson. 1992. *WIPP Small Scale Seal Performance Tests - Status and Impacts*. SAND91-2247. Albuquerque, NM: Sandia National Laboratories.
- Gulick, C.W., J.A. Boa, Jr., and A.D. Buck. 1980. *Bell Canyon Test (BCT) Cement Grout Development Report*. SAND80-1928. Albuquerque, NM: Sandia National Laboratories.
- Hansen, F.D., M.K. Knowles, J.R. Tillerson, J.D. Schreiber, and P. Vaughn. March 17, 1995. "Systems Prioritization Method - Iteration 2 Baseline Position Paper: Repository Seals Program." Albuquerque, NM: Sandia National Laboratories. (Copy available from Anita Reiser, Mail Stop 1341, Sandia National Laboratories, Albuquerque, NM.)

WIPP Sealing System Design Report

- Holt, R.M., and D.W. Powers. 1990. *Geologic Mapping of the Air Intake Shaft at the Waste Isolation Pilot Plant*. DOE-WIPP 90-051. Carlsbad, NM: Westinghouse Electric Corporation.
- Jarolimek, L., M.J. Timmer, and R.F. McKinney. 1983. *Geotechnical Activities in the Exploratory Shaft – Selection of the Facility Interval Waste Isolation Pilot Plant (WIPP) Project, Southeastern New Mexico*. TME-3178. Albuquerque, NM: U.S. Department of Energy, Waste Isolation Pilot Plant.
- Johnson, L.H., J.C. Tait, D.W. Shoesmith, J.L. Crosthwaite, and M.N. Gray. 1994. *The Disposal of Canada's Nuclear Fuel Waste: Engineered Barriers Alternatives*. AECL-10718. Pinawa, Manitoba, Canada: Whiteshell Laboratories.
- Lambe, T.W., and R.V. Whitman. 1969. *Soil Mechanics*. New York, NY: John Wiley & Sons.
- Mercer, J.W. 1983. *Geohydrology of the Proposed Waste Isolation Pilot Plant Site, Los Medaños Area, Southeastern New Mexico*. Water-Resources Investigations Report 83-4016. Albuquerque, NM: U.S. Geological Survey.
- Neville, A.M., 1975. *Properties of Concrete*. New York, NY: John Wiley & Sons.
- Nowak, E.J., J.R. Tillerson, and T.M. Torres. 1990. *Initial Reference Seal System Design: Waste Isolation Pilot Plant*. SAND90-0355. Albuquerque, NM: Sandia National Laboratories.
- Peterson, E.W., P.L. Lagus, and K. Lie. 1987. *Fluid Flow Measurements of Test Series A and B for the Small Scale Seal Performance Tests*. SAND87-7041. Albuquerque, NM: Sandia National Laboratories.
- Powers, D.W., S.J. Lambert, S-E. Shaffer, L.R. Hill, and W.D. Weart, eds. 1978. *Geological Characterization Report Waste Isolation Plant (WIPP) Site, Southeastern New Mexico*. SAND78-1596. Albuquerque, NM: Sandia National Laboratories. Vols. I-II.
- Pusch, R. 1982. "Mineral-Water Interactions and Their Influence on the Physical Behavior of Highly Compacted Na Bentonite," *Canadian Geotechnical Journal*. Vol. 19, no. 3, 381-387.
- Siegel, M.D., S.J. Lambert, and K.L. Robinson, eds. 1991. *Hydrogeochemical Studies of the Rustler Formation and Related Rocks in the Waste Isolation Pilot Plant Area, Southeastern New Mexico*. SAND88-0196. Albuquerque, NM: Sandia National Laboratories.
- Spiers, C.J., and R.H. Brzesowsky. 1993. "Densification Behavior of Wet Granular Salt: Theory Versus Experiments," *Proceedings, Seventh Symposium on Salt, Kyoto, Japan, April 6-9, 1992*. Eds. H. Kakihana, H.R. Hardy Jr., T. Hoshi, and K. Toyokura. Amsterdam: Elsevier Science Publishers B. Vol. I, 83-92.
- Spiers, C.J., and P.M.T.M. Schutjens. 1990. "Densification of Crystalline Aggregates by Fluid-Phase Diffusional Creep," *Deformation Processes in Minerals, Ceramics and Rocks, London, England, April 1987*. Eds. D.J. Barber and P.G. Meredith. London: Unwin Hyman. 334-353.
- Spiers, C.J., C.J. Peach, R.H. Brzesowsky, P.M.T.M. Schutjens, J.L. Liezenberg, and H.J. Zwart. 1989. *Long-Term Rheological and Transport Properties of Dry and Wet Salt Rocks*. EUR-11848. Luxembourg: Commission of the European Communities.

WIPP Sealing System Design Report

- Stormont, J.C., ed. 1986. *Development and Implementation: Test Series A of the Small-Scale Seal Performance Tests*. SAND85-2602. Albuquerque, NM: Sandia National Laboratories.
- Stormont, J.C. 1988. *Preliminary Seal Design Evaluation for the Waste Isolation Pilot Plant*. SAND87-3083. Albuquerque, NM: Sandia National Laboratories.
- Stormont, J.C., and C.L. Howard. 1986. *Development and Implementation: Test Series B of the Small-Scale Seal Performance Tests*. SAND86-1329. Albuquerque, NM: Sandia National Laboratories.
- Stoss, K., and B. Braun. 1983. "Sinking a Freeze Shaft with Installation of a Watertight, Flexible Lining," *Proceedings - 1983 Rapid Excavation and Tunneling Conference, Chicago, IL, June 12-16, 1983*. Eds. H. Sutcliffe and J.W. Wilson. New York, NY: Society of Mining Engineers of the American Institute of Mining, Metallurgical and Petroleum Engineers. 513-532.
- Thomas, O. 1957. "Sealing Shafts Using Bitumen," *Bergbautechnik*. Vol. 7, no. 2, 90-94. (Copy on file in the Sandia WIPP Central Files, Sandia National Laboratories, Albuquerque, NM.)
- Van Sambeek, L.L., D.D. Luo, M.S. Lin, W. Ostrowski, and D. Oyenuga. 1993. *Seal Design Alternatives Study*. SAND92-7340. Albuquerque, NM: Sandia National Laboratories.
- Valk, J. 1989. "Watertight Lining Systems to Secure Linking Shafts," *Transactions of the Institution of Mining & Metallurgy, Section A*. Vol. 98, A137-A143.
- Vine, J.D. 1963. *Surface Geology of the Nash Draw Quadrangle, Eddy County, New Mexico*. Geological Survey Bulletin 1141-B. Washington, DC: U.S. Government Printing Office.
- Wakeley, L.D., P.T. Harrington, and C.A. Weiss, Jr. 1993. *Properties of Salt-Saturated Concrete and Grout after Six Years In Situ at the Waste Isolation Pilot Plant*. SAND93-7019. Albuquerque, NM: Sandia National Laboratories.
- Wakeley, L.D., T.S. Poole, and J.P. Burkes. 1994. *Durability of Concrete Materials in High Magnesium Brine*. SAND93-7073. Albuquerque, NM: Sandia National Laboratories.
- Wakeley, L.D., P.T. Harrington, and F.D. Hansen. 1995. *Variability in Properties of Salado Mass Concrete*. SAND94-1495. Albuquerque, NM: Sandia National Laboratories.
- WIPP PA (Performance Assessment) Department. 1993. *Preliminary Performance Assessment for the Waste Isolation Pilot Plant, December 1992. Volume 5: Uncertainty and Sensitivity Analyses of Gas and Brine Migration for Undisturbed Performance*. SAND92-0700/5. Albuquerque, NM: Sandia National Laboratories.
- Yoder, E.J., and M.W. Witzczak. 1975. *Principles of Pavement Design*. 2nd ed. New York, NY: John Wiley & Sons.

WIPP Sealing System Design Report

**Appendix A:
Results of the Shaft Stratigraphy and Geohydrology Evaluation**

WIPP Sealing System Design Report

Appendix A: Results of the Shaft Stratigraphy and Geohydrology Evaluation

The purpose of evaluating the shaft stratigraphy and geohydrology at the Waste Isolation Pilot Plant (WIPP) is to establish the geologic and hydrologic information base required for design of the WIPP Facility Shaft Sealing System. The evaluation was completed in two phases. Phase I included:

- Confirmation of previously determined elevations of named stratigraphic unit contacts and marker beds from surface to total depth of the shafts, as ascertained from geotechnical reports on geologic mapping of each shaft during construction.
- Summary of regional groundwater occurrence intervals, as well as intervals of groundwater/ brine seeps logged during the geologic mapping of each shaft.
- Summary of clay presence in marker beds as logged during the geologic mapping of each shaft.
- Compilation of the stratigraphic data into a data base of named stratigraphic unit contacts and their mean sea level (MSL) elevations that intersect all four WIPP shafts.
- Construction of geologic structural cross-sections through the excavated shafts utilizing the compiled stratigraphic data base (SDB).

Phase II focused on further evaluation of brine occurrence within the exposed Salado Formation section and survey control for determining a reference point for use when determining subsurface depths. The Phase II evaluation of each shaft included:

1. Detailed correlation and projection of brine seepage intervals between the shafts, which was accomplished by compiling and evaluating data from available geotechnical shaft inspection reports, shaft geotechnical reports, and recently published groundwater reports to identify additional intervals of brine seepage that were not analyzed in previous shaft design studies.
2. Research of survey information to secure copies of the original survey plats, which document ground surface elevation for each shaft.
3. Review of shaft as-built diagrams to determine
 - a consistent surveyed datum, based on mean sea level (MSL), for reference when computing below-surface depths of named stratigraphic unit contacts and other relevant intervals of engineering design interest and
 - consistency between elevations of engineering and lithologic features in the shafts recorded on as-built drawings and shaft geotechnical reports.

A.1 Stratigraphic Evaluation

A.1.1 Correlation of Stratigraphic Contacts

Correlated stratigraphic unit contacts presented in the four shafts are expressed in MSL elevations. Figures 1 and 2 are geologic structural cross-sections based on MSL elevations. It

WIPP Sealing System Design Report

should be noted that there is a 400 ft (122 m) north-south offset between the Salt Handling shaft and the Waste Shaft as indicated on the figure legends. The cross-sections are presented here in a straight line format for ease of comparing stratigraphic consistency between adjacent shafts. These figures illustrate that the stratigraphic unit contacts are consistent both vertically and horizontally between the shafts. Some stratigraphic contact elevations vary because of regional structure and the stratigraphic thinning and thickening of units. However, the majority of the stratigraphic contacts used to date are suitable for the shaft stratigraphy correlation project because they intersect all four shafts. The exceptions are the following marker beds, listed in Table 1, which (1) do not correlate among all four shafts because of localized thinning and pinch-outs, (2) are erosional surfaces, or (3) simply were not recorded during the geologic mapping of the shaft wall.

Table 1. Marker beds unsuitable for correlation

Stratigraphic Contact	Comment
Mescalero Caliche	Not mapped in air intake and waste shafts.
Gatuña Formation	Not mapped in waste shaft.
Dewey Lake Red Beds	Erosional contact - highly irregular upper surface.
MB-100	Not present in all four shafts.
MB-119	Not present in all four shafts.
MB-120	Not present in all four shafts.
MB-125	Not present in all four shafts.
MB-133	Not present in all four shafts.
MB-137	Not present in all four shafts.
Anhydrite b	Not present in all four shafts.
MB-139	Not penetrated by all four shafts.

WIPP Sealing System Design Report

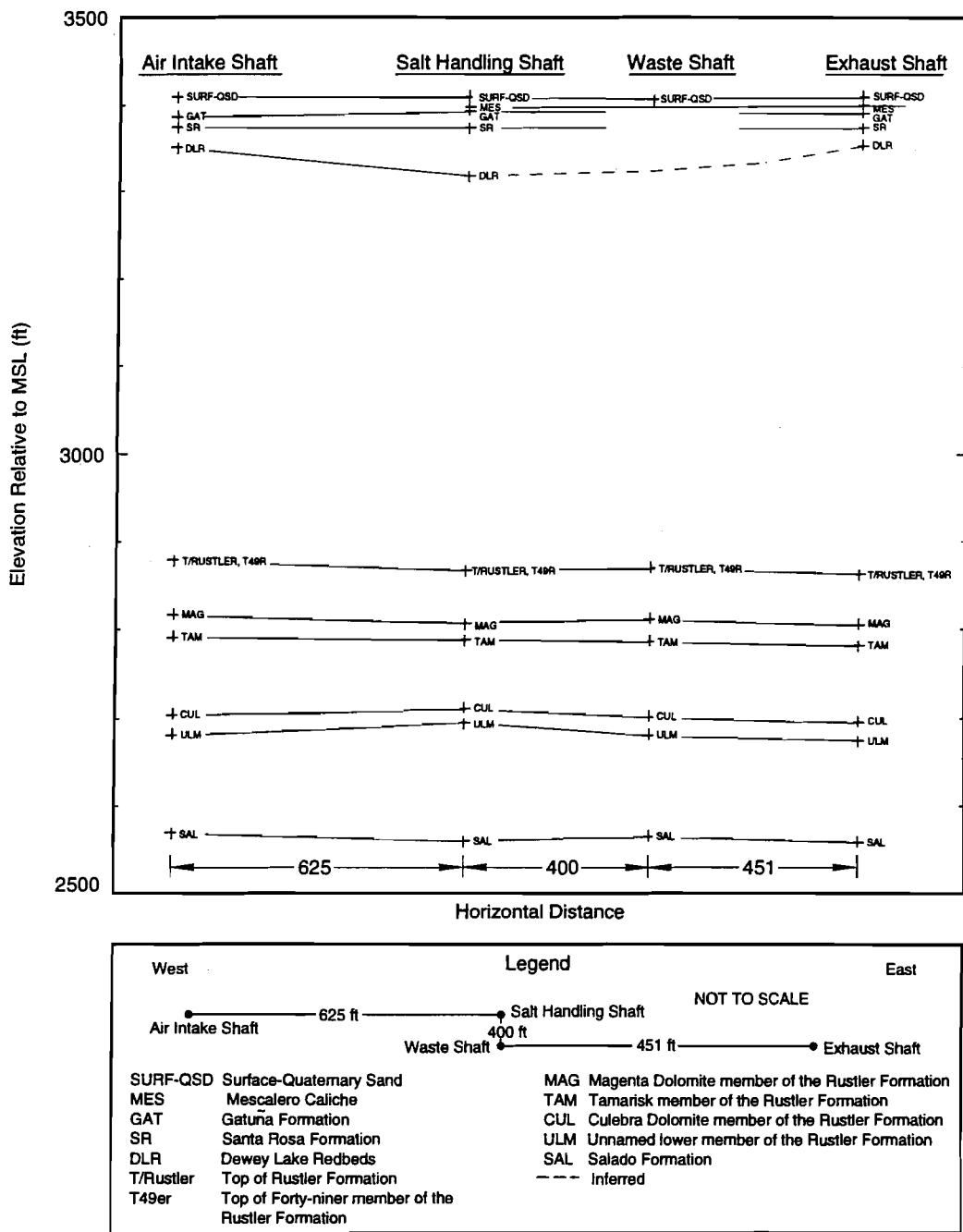

TRI-6121-212-2

Figure 1. Structural Cross-section through excavated shafts, ground surface to top of Salado Formation.

WIPP Sealing System Design Report

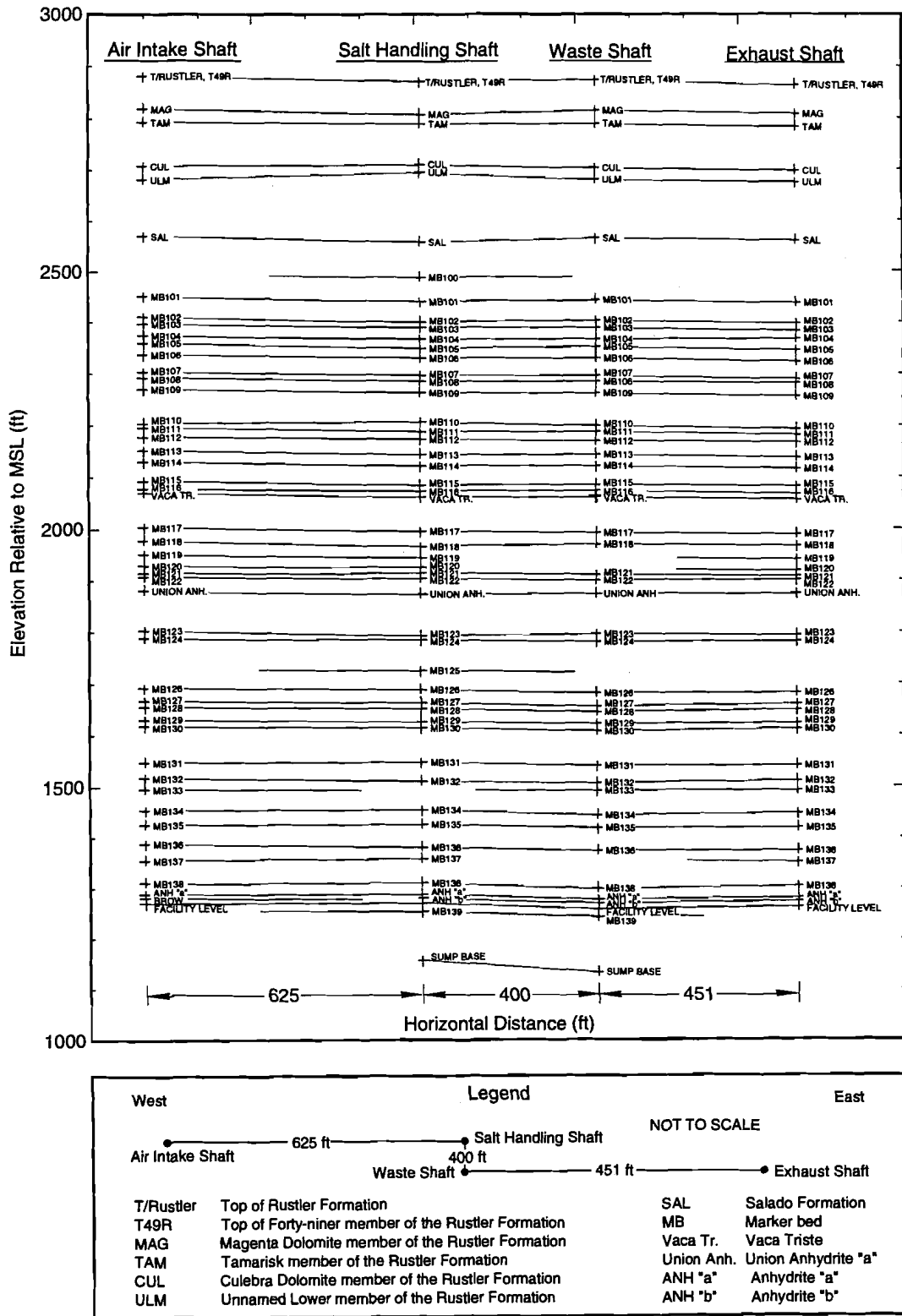

TRI-6121-211-2

Figure 2. Structural Cross-section through excavated shafts, top of Rustler Formation to total depth.

WIPP Sealing System Design Report

A.1.2 Sources of Information/Methodology of Stratigraphic Correlations

Lithologic logs, surface elevation references, and previous stratigraphic interpretation were secured from the sources listed in Table 2. It should be noted that, since its construction, the Salt Handling Shaft has had several names. At various times it has been called the *Exploratory Shaft*, the *Construction and Salt Handling Shaft*, and the *Salt Handling Shaft*. Currently, and therefore in this report, it is called the Salt Handling Shaft. Also note that the Waste Shaft was called the *Ventilation Shaft* during the initial phases of its construction.

Table 2. Stratigraphic information sources

Shaft	Document Number (Author)	Document Title
Exhaust	DOE-WIPP-86-008 (Holt and Powers, 1986)	Geotechnical Activities in the Exhaust Shaft
	DACW47-83-B-0010	Contract Drawings-CCP-1F6/1D Underground Experimental Areas/Waste Shaft and Exhaust Shaft (Drawing 35-R-004-01D)
Waste (formerly called Ventilation Shaft)	WTSD-TME-038(Holt and Powers, 1984)	Geotechnical Activities in the Waste Handling Shaft
	(TSC-D'Appolonia, 1983) GFDR No. 4	Geologic Mapping and Water Inflow Testing in the SPDV Ventilation Shaft
	WTSD-TME-3179 (Jarolimek et al., 1983b)	Correlation of Drillhole and Shaft Logs Waste Isolation Pilot Plant (WIPP) Project Southeastern New Mexico
Salt Handling (formerly called Exploratory or Construction & Salt Handling)	TME 3178 (Jarolimek, Timmer, and McKinney, 1983a)	Geotechnical Activities in the Exploratory Shaft-Selection of the Facility Interval
	WTSD-TME-3179 (Jarolimek, Timmer, and Powers, 1983b)	Correlation of Drillhole and Shaft Logs Waste Isolation Pilot Plant (WIPP) Project Southeastern New Mexico
	DOE-WIPP-86-010 (US DOE, 1986)	Waste Isolation Pilot Plant Design Validation Final Report Appendices
Air Intake	DOE-WIPP-90-051 (Holt and Powers, 1990)	Geologic Mapping of the Air Intake Shaft at the Waste Isolation Pilot Plant
	DACW47-83-B-0010	Contract Drawings - CCP-1F6/1D Underground Experimental Areas/Waste Shaft and Exhaust Shaft (Drawing 35-R-004-01D)

WIPP Sealing System Design Report

To confirm previous correlations, each shaft lithologic log was enlarged or reduced to a consistent scale of 1 in. = 10 ft. The lithologic log from the Air Intake Shaft (AIS) was used as the control log for correlations because it recorded the vertical occurrence of named stratigraphic unit contacts from ground surface to total depth at the facility level.

Correlation of the shaft logs required a side-by-side comparison with the AIS log. The tops and bases of the stratigraphic units were marked or confirmed and recorded as elevations relative to MSL. Several named stratigraphic unit contacts were not recorded on all four shaft logs during the original mapping program. Unrecorded named stratigraphic units were correlated with adjacent shaft logs. The newly correlated named stratigraphic unit contacts are listed in Table 3.

Table 3. Newly correlated named stratigraphic unit contacts

Shaft	Stratigraphic Unit	Unit Top (ft-MSL)
Exhaust	MB-125	Not Present (Pinched out)
	Waste	MB-119
	MB-120	Not Present (Pinched out)
	MB-125	Not Present (Pinched out)
Salt Handling	MB-130	1613.5
	MB-133	Not Present (Pinched out)
Air Intake	MB-106	2335.5
	MB-113	2150.0
	MB-114	2127.0
	MB-125	Not Present (Pinched out)
	Anhydrite a	1287.5

Ground surface (finished grade) MSL elevations and the survey control were recorded and evaluated for reliability. The surveyed ground surface (finished grade) MSL evaluations and reference sources are listed in Table 4.

A.1.3 Clay Associated with Marker Beds

Clay layers, when continuous, often form impermeable seams upon which water will migrate. When shafts are excavated, seeps or increased moisture content are often observed immediately above a clay layer. In some instances, if the clay was buried prior to dewatering, the clay layer can yield some water as it dewateres and consolidates after being exposed subsequent to shaft construction (Deal et al., 1995).

Clay was observed in association with a majority of the designated marker beds; it was located typically at the marker bed base and ranged from thin clay blebs (small, usually rounded inclusions of clay) to thicknesses of 1 ft. Most clay layers fall into a thickness range between 1 and 6 in. Occurrence of clay related to marker beds has been entered into the shaft SDB. Information relating to clay occurrence was secured from the lithologic logs in the following

WIPP Sealing System Design Report

reports: Holt and Powers, 1986; Holt and Powers, 1984; Jarolimek et al., 1983b; Holt and Powers, 1990.

Table 4. Surveyed ground surface (finished grade) MSL evaluations and reference sources

Shaft	Ground Surface (Elevation: ft-MSL)	Information Source
Exhaust	3410.0	Contract Drawings - CCP-1F6/1D;/ Drawing 35-R-004-01D. Based on USGS Survey Reference.
Waste	3407.5	Construction Survey; Table 1 WTSD-TME-038 (Holt and Powers, 1984) and Waste Shaft 311 General Arrangement Plans and Sections: Bechtel Job No. 12484 Drawing 31-R-013-01D Revision A
Salt Handling	3410.5	Surveyed Elevation tied to CWI Benchmark No. CW-1. DOE-WIPP 86-010 (US DOE, 1986)
Air Intake	3409.0	Contract Drawings CCP-1F6/1D;/ Drawing 35-R-004-01D based on USGS Survey Reference.

Although benchmark references were not noted for each shaft, each survey referenced a USGS Survey Reference.

A.1.4 Shaft Stratigraphic Data Base

The stratigraphic unit top and bottom MSL surface elevation, ground surface elevation (finished grade), and elevations of selected engineering features were recorded in a spreadsheet-based data base, the SDB. The SDB records the following information for each shaft:

- Engineering features (top of concrete, base of key, and station level)
- Ground Surface (finished grade)
- Stratigraphic unit contact name
- Unit top MSL elevation
- Unit bottom MSL elevation
- Groundwater/brine observance
- Clay observance
- Comments relating to the stratigraphic unit or engineering feature.

The MSL elevations were rounded to the nearest 0.10 ft. Values from 0.05 to 0.09 were rounded up, and values less than 0.05 were rounded down. SDB summaries for each shaft are provided in Section A4.0 of this appendix.

A.2 Groundwater / Brine Occurrence

A.2.1 Regional Groundwater Occurrence Intervals within the Shafts

A review of the regional geohydrology of the WIPP site and surrounding area identified six regional intervals of groundwater occurrence (Beauheim and Holt, 1990). These intervals are listed in Table 6.

Table 6. Regional Intervals of Groundwater Occurrence

Stratigraphic Unit	Remarks
Rustler Formation	
Forty-niner Member	Aquitard; water producing unit is a claystone interbedded with anhydrite and or gypsum units.
Magenta Dolomite Member	Regional aquifer; consists of fine grained gypsiferous arenaceous dolomite.
Tamarisk Member	Aquitard; consists of claystone sandwiched between two anhydrites.
Culebra Dolomite Member	Regional aquifer; consists of a finely crystalline, locally argillaceous and arenaceous, vuggy dolomite.
Unnamed Lower Member	Aquitard; consists of interbedded siltstone, sandstone, halite, and anhydrite. Regionally has two water producing units; however only one is present at the WIPP site. It is characterized by low permeability.
Rustler/Salado Formation Contact	Groundwater seeps at formation contact; general area of "brine aquifer" at Nash Draw

A.2.2 Groundwater / Brine Occurrence in the Salado Formation

A literature and data search was performed to identify groundwater/brine occurrence intervals in the Salado Formation. This search included review of geotechnical shaft reports, geotechnical shaft inspection reports, and WIPP site-specific published hydrologic/groundwater reports. Groundwater encountered in the Salado Formation appears in the form of seeps and weeps (i.e. small volumes of water oozing from the rock that produce a damp, moist, or wet surface). There has been no quantification of fluid flow associated with weeps or seeps. The groundwater is salt saturated and is identified in the literature as brine.

The geotechnical reports and associated lithologic logs for the Salt Handling, Waste, and Exhaust shafts did not include notations of observed brine seepage intervals within the Salado Formation section. The AIS geotechnical report (Holt and Powers, 1990), documenting the geologic mapping of the shaft, provided excellent data for identifying brine seepage intervals occurring within the Salado Formation section.

Within the AIS, seventeen intervals (excluding the potential seepage interval at the Rustler/Salado interface) are identified as producing brine seepage. The extent of seepage varied from the mention of recent weeps to abundant weeps. Two other zones of seepage below the repository (MB 139 and MB 140) that intersect shaft sumps in the waste and salt handling shafts were identified through personal communications with experimenters at Sandia National Laboratories for a total of 19 seepage intervals within the Salado Formation. The intervals located above the repository are listed in Table 7. Seepage intervals that did not correspond to a previously named lithologic unit were assigned zone designations for the purpose of conveying information in this report.

There were no notations indicating volume quantities of brine seepage from the identified seepage intervals. Four of the seventeen intervals observed in the AIS (MB 103, MB 124, Vaca

WIPP Sealing System Design Report

Triste siltstone, and Union Anhydrite) were identified during the AIS mapping as primary brine-producing intervals in the Salado Formation (Holt and Powers, 1990). Quantities of seepage observed in the AIS can be placed into perspective by contrasting the Salado Formation seepage notations with the recorded water-inflow data from the Rustler Formation aquifers in the Salt Handling Shaft. The Rustler Formation aquifers flowed less than a total of 1.5 gallons per minute into the shaft prior to liner installation. After liner installation, the inflow rate dropped to less than 0.1 gallons per minute (Jarolimek et al., 1983a). The Geotechnical Shaft reports for the Exhaust, Waste, and Salt Handling shafts did not indicate intervals of brine seepage deeper than the Rustler/Salado Formation interface; however, Saulnier and Avis (1988) conducted pulse injection tests using a multipacker tool at the 850 ft and the 1320 ft intervals within the Waste Handling Shaft. Within these intervals hydraulic conductivity values for halite, polyhalite, and anhydrite were determined. The hydraulic conductivities and associated derived intrinsic permeabilities (in parentheses) are recorded as follows:

- Halite: 1.0E-13 to 3.0E-14 m/s ($1 \times 10^{-20} \text{ m}^2$ to $4 \times 10^{-21} \text{ m}^2$)
- Polyhalite: 2.0E-14 m/s ($3 \times 10^{-21} \text{ m}^2$)
- Anhydrite: 3.0E-14 m/s ($4 \times 10^{-21} \text{ m}^2$).

To anticipate that the brine seepage intervals documented in the AIS have lateral extent and potentially intersect all four shafts, these intervals were projected through correlation of the shaft lithologic logs, from the AIS to the other four shafts, as illustrated in Figure 3. The cross-sections in Figures 4 through 7 illustrate the relationship of the newly designated brine seepage intervals (seepage zones) to the identified marker beds. These identified brine seepage intervals are recorded in the SDB for each shaft which is presented in Section A4.0 of this appendix.

Table 7. Brine seepage intervals occurring within the Salado Formation section

Marker Bed/Zone	Unit Top (ft-MSL)	Unit Bottom (ft-MSL)
MB103	2397.0	2380.5
MB109	2268.5	2243.1
Vaca Triste	2070.0	2062.0
Zone A	1925.0	1915.5
MB121	1915.5	1914.0
Union Anhydrite	1881.0	1873.5
MB124	1788.0	1779.1
Zone B	1736.5	1733.5
Zone C	1709.0	1700.0
Zone D	1650.5	1640.0
Zone E	1640.0	1638.0
Zone F	1638.0	1635.0
Zone G	1635.0	1633.0
Zone H	1633.0	1627.1
MB129	1627.1	1625.6
Zone I	1625.0	1619.3
Zone J	1546.9	1542.9

Note: Zones E through H are identified separately because of variable lithologies within that section of the AIS.

WIPP Sealing System Design Report

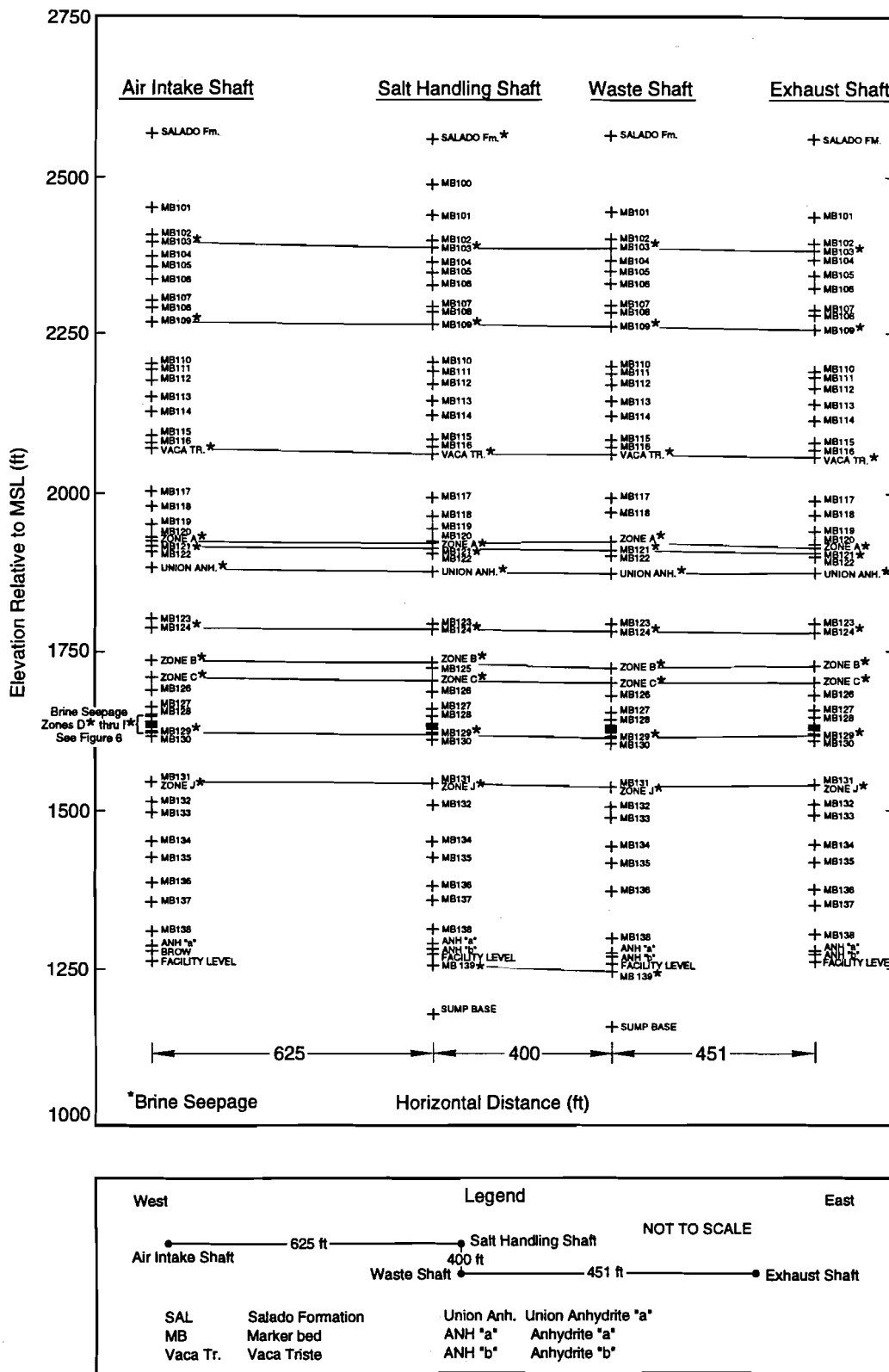

TRI-6121-242-2

Figure 3. Structural Cross-section through excavated shafts, showing correlation of mapped brine seepage intervals, top of Salado Formation to total depth.

WIPP Sealing System Design Report

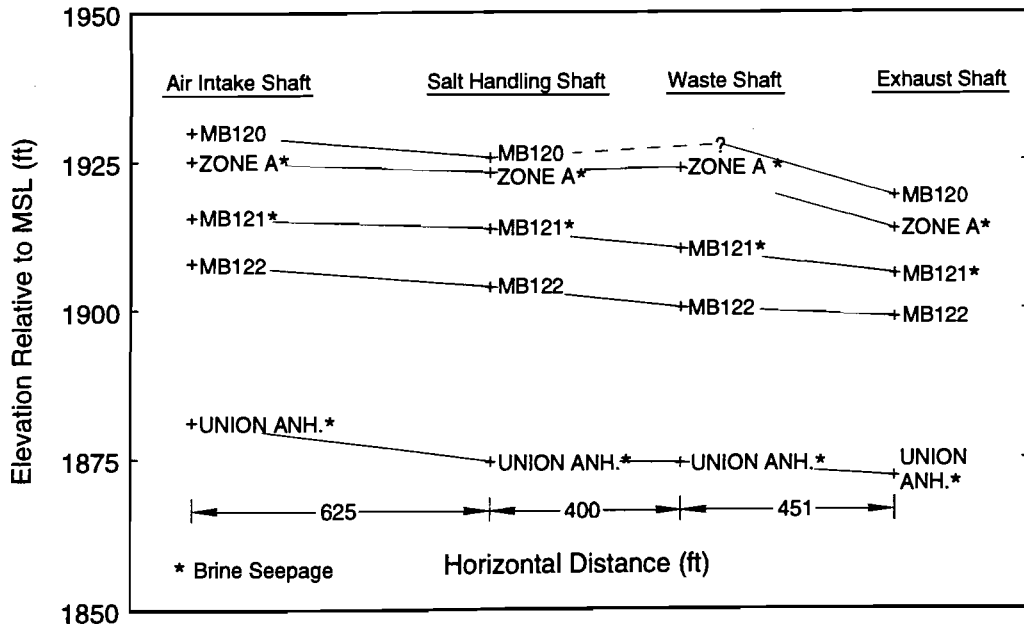

TRI-6121-243-0

Figure 4. Brine seepage zone A.

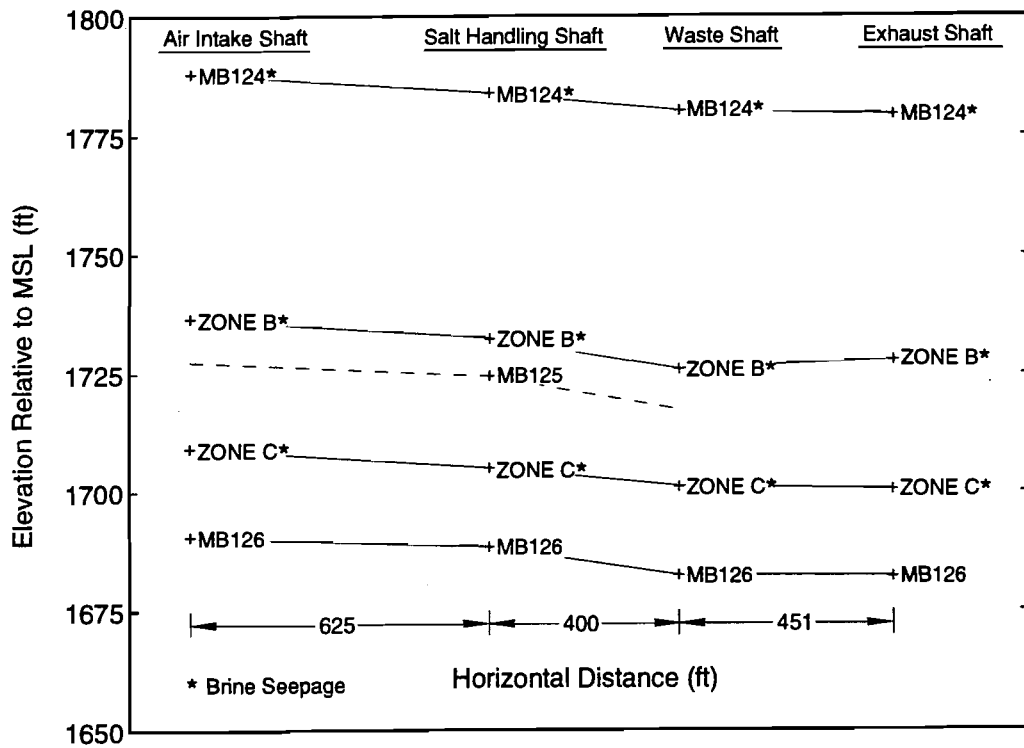

TRI-6121-246-0

Figure 5. Brine seepage zones B and C.

WIPP Sealing System Design Report

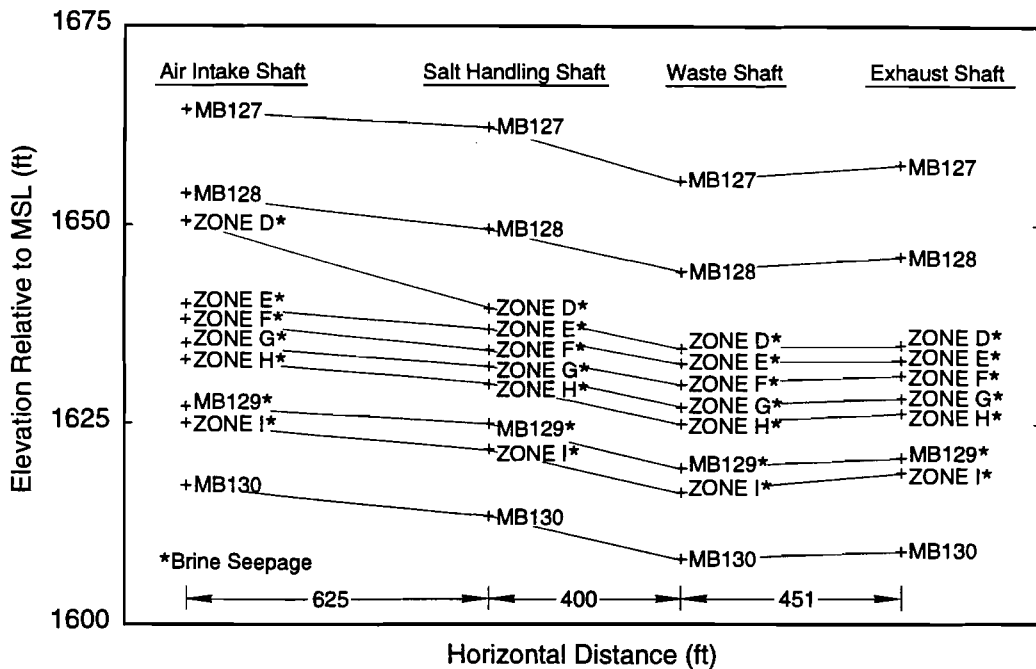

TRI-6121-245-0

Figure 6. Brine seepage zones D through I.

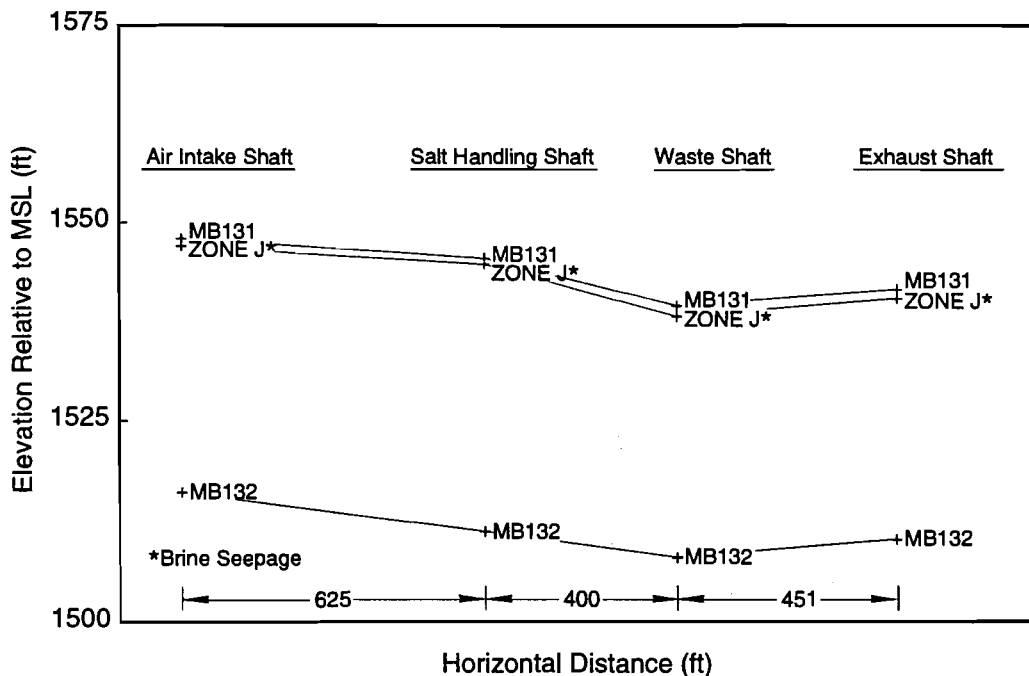

TRI-6121-244-0

Figure 7. Brine seepage zone J.

WIPP Sealing System Design Report

To evaluate current brine seepage conditions, Westinghouse Waste Isolation Division staff were contacted in January of 1994 concerning the availability of the shaft geotechnical inspection reports for each shaft. Staff members indicated that the reports are available for review; however, these inspection reports concentrate on groundwater conditions within the Rustler Formation (Lower Seal System) and that the reports do not denote brine seepage intervals in the Salado Formation (Salado Salt Column). During trips in and out of the shafts, some damp clay seams within the Salado Formation have been observed (conversation with Westinghouse engineering staff; January 1994). These intervals have not been logged in the shaft inspection reports. Westinghouse staff mentioned that the best records of brine seepage intervals in the Salado Formation are the lithologic logs that were assembled during the lithologic mapping of each shaft (Jarolimek et al., 1983b; Holt and Powers, 1984; Holt and Powers, 1990; Holt and Powers, 1986). These reports were obtained and used to assemble the SDB. Copies of the shaft inspection records were not requested because they do not note the brine seepage intervals in the Salado Formation penetrated by the shafts.

Subsequent to contacting Westinghouse Waste Isolation Division staff concerning availability of recent geotechnical inspection reports, an inspection— which emphasized observance of brine seepage and associated salt encrustations— was performed in the AIS (Deal et al., 1995). This inspection was conducted during July 1994 as part of the Brine Sampling and Evaluation Program (BSEP). As reported in Deal et al. (1995), the AIS observations were made from the shaft man cage which moves vertically approximately 9 feet from the shaft wall. The Salado section was initially observed on the way down to the repository level. A more detailed inspection was conducted during the ascent. On the ascent salt encrustations, indicating seepage when moist or previous seepage when dry, were marked according to their location on the lithologic log developed during shaft mapping (Holt and Powers, 1990). Seventy-three salt encrustations were logged during the observation. The encrustations observed were related to rock bolts, thin localized argillaceous (clayey) intervals and previously identified seepage intervals. Pictures taken of significant salt encrustations during the observations indicate that seepage associated with the encrustations was primarily localized (i.e. point source) with the exception being encrustations located in zones that were originally mapped as producing brine. MB 103 was the only encrustation interval that was observed to be wet indicating active brine seepage. From the man cage it was not possible to determine if there was moisture present beneath encrustations observed to be dry at the exposed surface. Most of the sulfate beds (anhydrite and polyhalite) and especially the polyhalite units showed no weeps or encrustations (Deal et al., 1995).

Observations were also conducted in the Waste and Salt Handling shafts (Deal et al., 1995). In these shafts the Salado section above the shaft sump was obscured primarily by grout spillage from shaft key and liner installation. Observations in the sump of the Waste and Salt Handling Shafts did not show moisture at the surface or in the open fractures of Marker Bed 139 (Deal et al., 1995).

A.2.3 Typical Rustler and Salado Formation Hydraulic Conductivity/Transmissivity Values

The literature was searched for hydraulic conductivity values associated with different lithologies encountered within the Salado Formation (Salado Salt Column Interval), as well as transmissivity data for water bearing units of the Rustler Formation. Such values will assist in relating the documented occurrences of brine seepage to potential fluid (brine) inflow to the

WIPP Sealing System Design Report

Salado Formation Subsystem. The hydraulic conductivity data for various lithologies encountered within the Salado Formation, and the transmissivity data for water bearing units encountered in the Rustler Formation (Forty-niner Member, Magenta Dolomite Member, Tamarisk Member, Culebra Dolomite Member, and the unnamed lower member), are profiled in Table 8.

Table 8. Typical Rustler and Salado Formation hydraulic conductivity/transmissivity values

Stratigraphic Unit	Lithology	Hydraulic Conductivity (m/day)	Transmissivity (m ² /day)	Relevant Reports/ Comments
Forty-niner Member	Claystone Clay		1.73E-05 to 3.46E-04	SAND87-0039 (Beauheim, 1987)
Magenta Dolomite Member	dolomite		9.23E-03 or less up to 9.29E-02	SAND90-2035J (Beauheim and Holt, 1990)
Tamarisk Member	claystone		9.29E-05 or less	SAND90-2035J (Beauheim and Holt, 1990)
Culebra Dolomite Member	dolomite		Less than 3.72E-04 to 1.16E+02	SAND90-2035J (Beauheim and Holt, 1990)
Unnamed Lower Member	silty claystone		9.29E-06 to 5.75E-05	SAND90-2035J (Beauheim and Holt, 1990); Potential communicator with Culebra. Three zones compose this unit; however, only zone 1 is present within the WIPP boundary.
Salado Formation	halite, argillaceous	1.22E-09 to 2.13E-08		SAND90-2035J (Beauheim and Holt, 1990)
	halite	Less than 3.05E-11 10.0E-14 to 2.59E-09		SAND90-2035J (Beauheim and Holt, 1990) SAND88-7001 (Saulnier and Avis, 1988)
	polyhalite	1.82E-09		SAND89-0462 (Lappin et al., 1989); Table 3-2 Waste Shaft
	anhydrite	1.73E-09 3.05E-08 to 6.09E-07 2.59E-09		SAND88-7001 (Saulnier and Avis, 1988) SAND90-2035J (Beauheim and Holt, 1990); MB139, approximately 3 ft thick. Hydraulic conductivity depends on the amount of fracturing present. Pore pressures show distinct gradient towards the underground facility. Pressures as high as 1700 psi have been measured at distances of 35 ft from excavations. SAND88-7001 (Saulnier and Avis, 1988)
*Note: Salado brines which flow into the WIPP Facility are not derived from fluid inclusions, but instead are grain boundary fluids with residence times of at least several million years (Stein and Krumhansl, 1986).				
*Note: Permeability increases around the facility within 5 to 10 ft because of fracturing and possible matrix dilation (Beauheim and Holt, 1990).				

A.3 Shaft Survey Data

A.3.1 Original Survey Coordinates and Surface Elevations

Westinghouse staff were contacted concerning the availability of the original survey plats that show the coordinates and the surface elevation of each shaft location prior to shaft construction. The original survey plats are not available; however, the shaft coordinates and surface elevations are recorded on the as-builts for each shaft. A comparison was made between the ground surface (finished grade) elevations secured from the Bechtel and Westinghouse as-built drawings for each shaft and those recorded in the SDB. Results of the comparison are presented in Table 9.

Table 9. Comparison between ground surface (finished grade) elevations secured from Bechtel and Westinghouse as-built drawings and those recorded in the SDB

Shaft	Ground Surface Elevation (Finished Grade) SDB (ft-MSL)	Surface Elevation Bechtel/Westinghouse As-Built (ft-MSL)	Difference In Elevation Data (SDB less As-Built) (ft)
Air Intake	3409.0	3409.0	0.0
Exhaust	3410.0	3409.9	0.1
Salt Handling	3410.5	3411.0	-0.5
Waste	3407.5	3407.5	0.0

The comparison of surface elevation data illustrates relative consistency between (1) surface elevations reported in geotechnical reports and working drawings, and (2) the data recorded on the Bechtel/Westinghouse as-built drawings for each shaft. The two minor discrepancies noted are in the Exhaust Shaft and the Salt Handling Shaft, which reflected differences of 0.1 ft and 0.5 ft respectively.

A.3.2 Review of Shaft As-Built Drawings to Determine a Consistent Surveyed Datum

Current shaft as-built drawings were secured from Westinghouse. These drawings were reviewed to determine a consistent surveyed datum, based on MSL, for reference when computing below-surface depths of named stratigraphic unit contacts and other relevant intervals of engineering design interest. The shaft as-built drawings for each of the shafts utilized a surveyed reference datum elevation of 3409.0 ft MSL based on the 1927 USGS North American Datum. For computing below-surface depths in the shafts, the reference datum of 3409.0 ft MSL is equated to a reference level 0'-0" (i.e., reference level 0'-0" = 3409.0 ft-MSL based on the USGS North American Datum). Elevations of selected features and/or objects within each shaft, and the reference drawings used to determine these elevations, are incorporated into the SDB (Attachment 1). The as-built drawings reviewed for each shaft and general survey information are marked "Info Only" and are current to February 18, 1994. The survey information and shaft as-built drawings reviewed are outlined in Tables 10 through 14.

WIPP Sealing System Design Report

Table 10. Site Work/Site development overall plans

Drawing Number	Title
24-C-053-005 Rev. B Sheet 1/2 and 2/2	Site Work, Site Development Overall Plan. (Inactivated per ECO#5667)
24-C-060-005 Rev. A Sheet 1/2 and 2/2	Site Work – Rough Grading Plan. (Inactivated per ECO#5567)
24-C-075-005 Rev. B. Sheet 1/2 and 2/2	Site Work – Rough Grading Plan and Sections. (Inactivated per ECO#5567)
24-C-078-005 Rev. B Sheet 1/2 and 2/2	Site Work – Rough Grading Sections.
21-C-011-SF9 Rev. 10	Base Line Monuments Plans & Sections.
21-V-002-W Rev. B	WIPP Site Surveys and Subsidence Monuments.
21-C-0012-SF9 Rev. 6	Subsidence Monuments Plans and Details.

Table 11. Air Intake Shaft as-builts reviewed

Drawing Number	Title
33-R-001-34A Rev. 4	Air Intake Shaft 331 General Arrangement Plans and Sections.
33-D-002-W	Air Intake Shaft 331 Shaft Collar/Air Intake Platform Plan, Sections and Details (new).
33-C-001-W	Air Intake Shaft 331 Shaft Collar/Air Intake Platform Plan, Sections and Details (new).
33-C-004-W1 and W2	Air Intake Shaft 331 Shaft Key Plan, Sections and Details (new).
33-D-008-W	Air Intake Shaft 331 General Arrangement (new).
51-W-212-W	Air Intake Shaft 331 Shaft Station Plans, Sections and Details.

WIPP Sealing System Design Report

Table 12. Salt Handling (Exploratory Shaft) as-builts reviewed

Drawing Number	Title
37-R-010 Rev. A	Key and Shaft Station Location Section. General Arrangement at Surface Plan and Section. Key Sections and Details. C&SH Shaft Collar Modification Plan Sections & Details. C&SH Shaft Collar Area. C&SH Shaft Collar Modification Plan Section & Details. Station Develop. - Experimental Level Plan and Sections. Key and Shaft Station Location Section.
37-R-023 Rev. A	
37-R-012 Rev. A	
24-C-202-05A Rev. A	
24-C-202-1Fc-4 Rev. G p.7	
37-R-019 Rev. A	
37-R-010 Rev. A	

Table 13. Waste Shaft as-builts reviewed

Drawing Number	Title
31-R-001-01D Rev. B	Waste Shaft 311 Shaft Development Sections. Waste Shaft 311 Shaft Lining and Key Section and Details. Waste Shaft 311 General Arrangement Plans and Sections. As-Built for Waste Shaft Collar.
31-R-002-01D Rev. A	
31-R-013-01D Rev. B	
A-0001	

Table 14. Exhaust Shaft as-builts reviewed

Drawing Number	Title
S-020	Exhaust Shaft with Collar Layout. Detail Exhaust Shaft Layout. Exhaust Shaft 351 General Arrangement Plans and Sections. Exhaust Shaft 351 Shaft Living and Key Section and Details. Exhaust Shaft 351 General Arrangement Plans and Sections.
S-024	
35-R-004-01D Rev. B	
35-R-002-01D Rev. A.	
35-R-004-01D Rev. A	

A.3.3 Designation of Surface Reference Point

A physical surface reference point needs to be designated for the shafts to facilitate completion of the sealing system design drawings and final seal emplacement. It was recommended that the designated surface reference point elevation chosen for the shaft seal design drawings be the “top of concrete” for each shaft. “Top of concrete” is defined as the top of the collar for the Waste and Exhaust shafts, and the top of the existing shaft for the Salt Handling Shaft. “Top of concrete” for the AIS is defined as the top of the plenum. Table 15 identifies the designated surface reference, surface reference elevation (ft-MSL), and the distance above or below the current WIPP reference level 0’-0” (3409.0 ft MSL).

Table 15. Designated surface reference, surface reference elevation (ft-MSL), and distance above or below current WIPP reference level 0’-0” (3409.0 ft MSL).

Shaft	0’-0” Designated Surface Reference	Designated Surface Reference Elevation (ft-MSL)	Distance (ft) Above or Below Current WIPP Reference Level 0’-0” (3409.0 ft-MSL)
AIS	Top of Plenum	3410.0	1.0 Above
Waste	Top of Pad	3408.5	0.5 Below
Exhaust	Top of Collar	3411.5	2.5 Above
Salt Handling	Top of Existing Shaft	3411.5	2.5 Above

Designating the surface references as outlined in Table 15 will:

1. allow shaft seal designs to be developed with depth measurements measured from a consistent reference point that is specific to each shaft,
2. provide an easily identifiable reference that should still be in existence at the time the shafts are sealed, and
3. avoid the confusion created during shaft sealing operations that can arise from taking measurements from a reference level that is not tied to a physical shaft object.

To avoid future confusion when comparing existing shaft as-builts and final shaft seal design drawings, the seal design drawing notes should clearly identify the designated surface reference point and its relationship to the WIPP Standard Reference Level 0’-0” at 3409.0 ft-MSL.

A.3.4 Comparison of Stratigraphic Data Base and As-Built Elevations

Information from the SDB and the shaft as-built drawings were compared to determine discrepancies that may exist between the geologic data secured from the lithologic logs and the geologic data recorded on the shaft as-built drawings.

Elevation comparisons were made for select shaft and geologic features that were identified in both data sources. Features compared are specifically outlined for each shaft in Sections 3.4.1 through 3.4.4 and their associated tables.

In general, elevations were compared for the following geologic/shaft features:

- Ground surface (finished grade)
- Mescalero caliche

WIPP Sealing System Design Report

- Gatuña Formation
- Magenta Dolomite Member
- Culebra Dolomite Member
- Salado Formation
- Base of Key
- Shaft Station level.

If the feature and associated MSL elevation were identified in both data sources, the feature will be included in the comparison table for that specific shaft. Comparisons of elevations from both data sources showed differences varying from a minimum of 0.0 ft to a maximum of 9.0 ft as outlined in the following sections. The major discrepancies between the two data sources are found in the comparisons of the AIS and the Salt Handling Shaft. None of the data discrepancies in any single shaft was consistent enough to suggest that application of a single correction factor to either data set would reconcile the data.

Identifying lithologic contacts, especially when the contacts are gradational, can be a highly interpretive process. The difference in elevation values between the data sets (approximately ft or less) indicates a general consensus about the locations of the geologic features/objects relative to MSL. The as-built drawings should reflect the lithologic contacts mapped after the construction of each shaft. These differences in elevation indicate that some of the as-built lithologic contact elevations may have been transferred from preconstruction shaft design drawings to the final as-built drawings.

A.3.4.1 Air Intake Shaft

Ground surface (finished grade) elevations are consistent between the two data sources. The as-built elevations for the Magenta Dolomite Member, Salado Formation, and the base of the Shaft Key are consistent to within 0.3 ft relative to elevations secured from the shaft lithologic log. The Culebra Dolomite Member elevation recorded on the as-builts is 9.0 ft low relative to elevations secured from the shaft lithologic log. Conversation with Westinghouse staff revealed that the elevation for the as-built elevation for the Culebra Dolomite member should reference the elevation recorded in Holt & Powers (1990). By referencing this report and placing the unit in its proper scaled position on the drawing this discrepancy is eliminated. Table 16 compares the AIS lithologic log to the as-built elevations.

Table 16. Air Intake Shaft lithologic log versus as-built elevations

Geologic Feature/Object	Lithologic Log Elevation (ft-MSL)	As-built Elevation (ft-MSL)	Difference in Elevation: Lithologic Log less As- built (ft MSL)
Ground surface (finished grade)	3409.0	3409.0	0.0
Magenta Dolomite Member	2817.6	2817.6	0.0
Culebra Dolomite Member	2705.0	2696.0	9.0
Salado Formation	2569.3	2569.0	0.3
Base of Key	2513.0	2513.0	0.0

A.4.4.2 Exhaust Shaft

The ground surface (finished grade) elevation and the elevations of the Magenta Dolomite Member and Culebra Dolomite Member are consistent to within 0.1 ft. The Mescalero Caliche and the Gatuña Member elevations differ by 2.5 ft and 2.0 ft respectively. Table 17 compares the Exhaust Shaft lithologic log to the as-built elevations.

Table 17. Exhaust Shaft lithologic log versus as-built elevations

Geologic Feature/Object	Lithologic Log Elevation (ft-MSL)	As-built Elevation (ft-MSL)	Difference in Elevation: Lithologic Log less As-built (ft-MSL)
Ground surface (finished grade)	3410.0	3409.9	0.1
Mescalero Caliche	3401.5	3399.0	2.5
Gatuña Formation	3391.9	3389.9	2.0
Magenta Dolomite Member	2806.4	2806.5	-0.1
Culebra Dolomite Member	2695.4	2695.5	-0.1
Salado Formation	2558.5	2558.5	0.0

A.3.4.3 Waste Shaft

The ground surface (finished grade) elevation and the elevations of the Magenta Dolomite Member and the Culebra Dolomite Member are consistent. Elevations for the Salado Formation and the Shaft Station Level differ by 0.3 ft and 2.0 ft respectively. Table 18 compares the Waste Shaft lithologic log to the as-built elevations.

Table 18. Waste Shaft lithologic log versus as-built elevations

Geologic Feature/Object	Lithologic Log Elevation (ft-MSL)	As-built Elevation (ft-MSL)	Difference in Elevation: Lithologic Log less As-built (ft MSL)
Ground surface (finished grade)	3407.5	3407.5	0.0
Magenta Dolomite Member	2813.0	2813.0	0.0
Culebra Dolomite Member	2702.5	2702.5	0.0
Salado Formation	2565.3	2565.0	0.3
Shaft Station Level	1247.0	1249.0	-2.0

A.3.4.4 Salt Handling Shaft

Ground surface (finished grade) elevations are consistent to within 6 in. The Magenta Dolomite Member, Culebra Dolomite Member, and the Salado Formation elevations vary from 2 to 8 ft. Discrepancies in data result from recording as-built lithologic data from borehole ERDA-9 (see note on drawing 37-R-010, Rev. 7), which is an offset to the shaft. Table 19 compares the Salt Handling Shaft lithologic log to the as-built elevations.

WIPP Sealing System Design Report

Table 19. Salt Handling Shaft lithologic log versus as-built elevations

Geologic Feature/Object	Lithologic Log Elevation (ft-MSL)	As-built Elevation (ft-MSL)	Difference in Elevation: Lithologic Log less As-built (ft MSL)
Ground surface (finished grade)	3410.5	3411.0	-0.5
Magenta Dolomite Member	2808.0	2816.0	-8.0
Culebra Dolomite Member	2711.0	2705.0	6.0
Salado Formation	2560.0	2558.0	2.0

A.4 Stratigraphic Database

The Stratigraphic database presents geologic and hydrogeologic information for each individual shaft along with select engineering features (i.e., top of concrete, base of key, and station level). Specifically, information recorded for each shaft includes:

- Engineering features (top of concrete, base of key, and station level)
- Ground Surface (finished grade)
- Stratigraphic unit contact name
- Unit top and bottom MSL elevation
- Groundwater/brine observance
- Clay observance
- Comments relating to stratigraphic unit or engineering features.

WIPP Sealing System Design Report

A.4.1 Air Intake Shaft Stratigraphic Database

Stratigraphic Unit/Engineering Feature	Unit/feature Top (ft-msl)	Unit/Feature Bottom (ft-msl)	Water/Brine Obs.	Clay Obs.	Comments
Top of Concrete	3410.0				Bechtel Drawing 33-R-001-34A Rev. 4, Air Intake Shaft 331 General Arrangement Plans and Sections and 33-R-012-34A Rev. 5, Air Intake Shaft 331 Shaft Development 16'-0" Diameter Shaft Sections
Ground Surface (SURF) /Finished Grade	3409.0				Ground surface (finished grade): 3409.00 ft msl based on USGS survey Marker; Shaft Development Drawing # 33R-012-34A. Stratigraphic contacts are from lithologic log; DOE-WIPP-90-051
Quaternary Sd. (QSD)	3409.0	Not mapped			
Mescalero Caliche (MES)	Not mapped	Not mapped			
Gatuna Fm. (GAT)	3387.5	3378.5			
Santa Rosa Fm. (SR)	3378.5	3353.1			
Dewey Lk Rb. (DLR)	3353.1	2878.7			Top contact is an erosional surface
Rustler Fm. (RUS)	2878.7	2569.3			
49-er mbr (49R)	2878.7	2817.6	x		Groundwater, regional aquitard; at some locations a thin claystone has a transmissivity comparable to the Magenta. SAND90-2035J
Magenta D. mbr (MAG)	2817.6	2792.0	x		Groundwater, regional; SAND90-2035J & DOE-WIPP 90-051
Tamarisk mbr (TAM)	2792.0	2705.0	x		Groundwater, regional aquitard; SAND90-2035J
Culebra D. mbr (CUL)	2705.0	2681.1	x		Groundwater, regional; SAND90-2035J & DOE-WIPP 90-051
Unnamed L. mbr (ULM)	2681.1	2569.3	x		Groundwater, regional aquitard (siltstone unit at H-16); SAND90-2035J
Salado Fm. (SAL)	2569.3	Did not penetrate	x		Regional potential for Groundwater (brine) occurrence at the Rustler /Salado Fm. contact; SAND90-2035J. No Groundwater at Fm. contact noted on lithologic log. Shaft did not penetrate base of unit.

WIPP Sealing System Design Report

Stratigraphic Unit/Engineering Feature	Unit/feature Top (ft-msl)	Unit/Feature Bottom (ft-msl)	Water/Brine Obs.	Clay Obs.	Comments
Key (See Comments)		2513.0			Elevation 2513.0 ft.-msl from Westinghouse Isolation Division (WID) Drawing 33-C-004-W1, Air Intake Shaft 331 Shaft Key Plan, Sections and Details. This elevation is seven (7) feet higher than the base of Key concrete reported on the AIS lithologic log.
MB 100	*	*			Not marked on log
MB 101	2450.5	2447.1			
MB 102	2409.1	2408.0			
MB 103	2397.0	2380.5	x		Brine; Weeps - moist surface in lower 4ft; DOE-WIPP-90-051; Anhydridic dolomite overlying claystone where weeps occur.
MB 104	2373.5	2372.5			
MB 105	2356.6	2355.5			
MB 106	2335.5	2335.0			Correlated with exploration shaft.
MB 107	2301.0	2300.5			
MB 108	2291.1	2290.5			
MB 109	2268.5	2243.1	x		Brine; Weeps: DOE-WIPP-90-051, weep symbol on log with no weep description. Weeps occur in mudstone with anhydrite nodules.
MB 110	2203.1	2202.0			
MB 111	2194.5	2193.9			
MB 112	2176.4	2174.4		x	Thin laminae.
MB 113	2150.0	2149.0			Correlated with exploration shaft.
MB 114	2127.0	2126.0			Correlated with exploration shaft.
MB 115	2091.5	2088.0			
MB 116	2078.5	2076.0			
Vaca Triste (VACA TR)	2070.0	2062.0	x		Brine; DOE-WIPP-90-051. Composed of halitic siltstone and mudstone.
MB 117	2001.0	1999.5			
MB 118	1977.6	1975.0			
MB 119	1950.4	1948.4			
MB 120	1929.9	1929.0		x	Thin clay layers/blebs.
Zone A	1925.0	1915.5	x		Brine; Some weeps, halite with a trace of polyhalite: DOE-WIPP-90-051 - AIS log

WIPP Sealing System Design Report

Stratigraphic Unit/Engineering Feature	Unit/feature Top (ft-msl)	Unit/Feature Bottom (ft-msl)	Water/Brine Obs.	Clay Obs.	Comments
MB 121	1915.5	1914.0	x	x	Brine; Weeps: DOE-WIPP-90-051 - AIS log. Weep symbol on log near base of unit (polyhalite) - no description. 2-3" clay at base.
MB 122	1907.9	1906.9			
Union Ahh.	1881.0	1873.5	x		Brine; Unit as a whole bears fluid. Weeps parallel to strata are very common around zones with clastic halite. Weeps occur also around fractures and contacts. DOE-WIPP-90-051 - AIS log
MB 123	1801.5	1795.0			
MB 124	1788.0	1779.1	x		Brine; Recent weeps parallel to fractures and bedding planes in anhydrite: DOE-WIPP-90-051 - AIS log
Zone B	1736.5	1733.5	x		Brine; Abundant weeps, halite argillaceous to trace clay: DOE-WIPP-90-051 - AIS log
Zone C	1709.0	1700.0	x		Brine; Modest amount of weeps, halite, trace clay and polyhalite: DOE-WIPP-90-051 - AIS log
MB 125	Absent	Absent			Section absent (Pinched out).
MB 126	1690.6	1689.5			
MB 127	1664.6	1662.0		x	Thin clay layers/blebs in upper 1 ft.
MB 128	1654.0	1650.5		x	Thin clay layers at base.
Zone D	1650.5	1640.0	x		Brine; Weeps in lower most part, interbedded polyhalite and argillaceous halite: DOE-WIPP-90-051 - AIS log
Zone E	1640.0	1638.0	x		Brine: Weeps in pits, argillaceous halite: DOE-WIPP-90-051 - AIS log
Zone F	1638.0	1635.0	x		Brine; Moderate weeps in unit, halite with trace polyhalite and clay: DOE-WIPP-90-051 - AIS log
Zone G	1635.0	1633.0	x	x	Brine; Abundant weeps from pits, argillaceous halite and halitic claystone: DOE-WIPP-90-051 - AIS log
Zone H	1633.0	1627.1	x		Brine; Moderate weeps, halite and polyhalite: DOE-WIPP-90-051 - AIS log
MB 129	1627.1	1625.6	x		Brine; Abundant weeps: DOE-WIPP-90-051 - AIS log
Zone I	1625.0	1619.3	x	x	Brine; Weeps, halite with polyhalite and claystone interbeds: DOE-WIPP-90-051 - AIS log

WIPP Sealing System Design Report

Stratigraphic Unit/Engineering Feature	Unit/feature Top (ft-msl)	Unit/Feature Bottom (ft-msl)	Water/Brine Obs.	Clay Obs.	Comments
MB 130	1617.2	1615.1		x	Thin clay layers/blebs at base.
MB 131	1547.9	1546.9			
Zone J	1546.9	1542.9	x		Brine; Abundant weeps, halite trace to some clay and polyhalite: DOE-WIPP-90-051 - AIS log
MB 132	1516.0	1515.0			
MB 133	1497.1	1495.6			
MB 134	1454.0	1441.9			
MB 135	1426.0	1425.0			
MB 136	1387.2	1373.1			
MB 137	1356.3	1355.0			
MB 138	1311.1	1310.6			
Anhydrite "a" (ANH "a")	1287.5	1286.5			
Anhydrite "b" (ANH "b")	Not mapped	Not mapped			
Brow	1279.5				Excavated brow at facility level. MB-139 thru 142 were not penetrated by the shaft.
Station Level		1259.0			Westinghouse Isolation Division (WID) DWG. 33-D-008-W Air Intake Shaft 331 General Arrangement and WID DWG. 51-W-212-W Air Intake Shaft Station Plans, Sections and Details. Station level not on lithologic log.
					MB-139 thru 142 were not penetrated by the Air Intake Shaft.

WIPP Sealing System Design Report

A.4.2 Exhaust Shaft Stratigraphic Database

Stratigraphic Unit/Engineering Feature	Unit/feature Top (ft-msl)	Unit/Feature Bottom (ft-msl)	Water/Brine Obs.	Clay Obs.	Comments
Top of Concrete	3411.5				Bechtel Drawing 35-R-001-01D Rev. B, Exhaust Shaft 351 Development Plan Sections and Detail
Ground Surface (SURF) /Finished Grade	3410.0				Ground Surface (finished grade) 3410 ft. MSL. Based on survey-USGS 1927 North American datum.
					Contract Drawings-CCP1Fb/1D, Underground Experimental Areas/Waste Shaft and Exhaust Shaft. Drawing 35-R-004-01D. Stratigraphic contacts from lithologic log; DOE-WIPP-86-008.
Quaternary Sd (QSD)	3410.0	3401.5			
Mescalero Caliche (MES)	3401.5	3391.9			
Gatuna Fm. (GAT)	3391.9	3375.0			
Santa Rosa Fm. (SR)	3375.0	3355.4			
Dewey Lk. Rb. (DLR)	3355.4	2862.5		x	Top contact is an erosional surface. Occasional thin clay layers (<6" thick)
Rustler FM. (RUS)	2862.5	2558.5			
49-er mbr (49R)	2862.5	2806.4	x		Groundwater, regional aquitard; at some locations a thin claystone has a transmissivity comparable to the Magenta. SAND90-2035J
Magenta mbr (MAG)	2806.4	2782.0	x		Groundwater, regional; Sand90-2035J; DOE-WIPP-86-008
Tamarisk mbr (TAM)	2782.0	2695.4	x	x	Groundwater, regional aquitard; SAND90-2035J. Occasional thin clay layers < 6" thick.
Culebra D mbr (CUL)	2695.4	2673.0	x		Groundwater, regional; SAND90-2035J; DOE-WIPP-86-008
Unnamed L mbr (ULM)	2673.0	2558.5	x	x	Groundwater, regional aquitard (siltstone unit at H-16); SAND90-2035J. Occasional thin clay layers (< 6" thick)
Salado Fm. (SAL)	2558.5	Did not penetrate	x		Regional potential for Groundwater (brine) occurrence at the Rustler /Salado Fm. contact; SAND90-2035J. No Groundwater at Fm. contact noted on lithologic log. Shaft did not penetrate base of unit.

WIPP Sealing System Design Report

Stratigraphic Unit/Engineering Feature	Unit/feature Top (ft-msl)	Unit/Feature Bottom (ft-msl)	Water/Brine Obs.	Clay Obs.	Comments
Key (See Comments)		2502.0			Elevation 2502 ft.-msl (level 907.00) calculated from Bechtel Drawing 35-R-002-01D Rev. A, and Exhaust Shaft 351 Shaft Lining and Key Section and Detail.
MB 100	*	*			Not marked on log
MB 101	2436.5	2433.5			
MB 102	2394.8	2393.6		x	Clay near base (3" thick)
MB 103	2382.0	2367.0			Potential brine seepage interval-inferred from AIS brine seepage conditions
MB 104	2359.0	2358.7			
MB 105	2342.9	2341.8		x	Clay at base
MB 106	2322.5	2321.8		x	Clay at base (1" thick)
MB 107	2289.0	2288.5			
MB 108	2279.7	2277.5		x	Clay at base (2" thick)
MB 109	2256.0	2230.5			Potential brine seepage interval-inferred from AIS brine seepage conditions
MB 110	2191.8	2189.6		x	Clay at base
MB 111	2181.8	2181.4			
MB 112	2164.2	2161.9		x	Clay at base (1" - 2.5" thick)
MB 113	2137.8	2136.4		x	Clay at base (2" thick)
MB 114	2114.6	2113.8			
MB 115	2078.9	2075.5		x	Clay at base (1" thick)
MB 116	2066.3	2064.0		x	Clay at base (1" thick)
Vaca Triste (VACA TR)	2055.3	2051.0			Potential brine seepage interval-inferred from AIS brine seepage conditions
MB 117	1988.6	1987.3			
MB 118	1965.0	1962.7		x	Clay (1" - 2" thick)
MB 119	1938.9	1937.0			
MB 120	1919.0	1918.3			
Zone A	1913.5	1905.6			Potential brine seepage interval-inferred from AIS brine seepage conditions
MB 121	1913.5	1905.6			Potential brine seepage interval-inferred from AIS brine seepage conditions
MB 122	1898.5	1897.0			
Union Anhydrite	1872.0	1866.0			Potential brine seepage interval-inferred from AIS brine seepage conditions
MB 123	1793.0	1786.0			

WIPP Sealing System Design Report

Stratigraphic Unit/Engineering Feature	Unit/feature Top (ft-msl)	Unit/Feature Bottom (ft-msl)	Water/Brine Obs.	Clay Obs.	Comments
MB 124	1779.3	1770.0		x	Potential brine seepage interval- inferred from AIS brine seepage conditions. Clay (1" - 2" thick)
Zone B	1727.8	1724.3			Potential brine seepage interval-inferred from AIS brine seepage conditions
Zone C	1700.3	1690.8			Potential brine seepage interval-inferred from AIS brine seepage conditions
MB 125	Absent	Absent			Section absent (Pinched out).
MB 126	1682.0	1681.5			
MB 127	1657.5	1655.3			
MB 128	1646.0	1644.3			
Zone D	1634.8	1633.0			Potential brine seepage interval-inferred from AIS brine seepage conditions
Zone E	1633.0	1631.0			Potential brine seepage interval-inferred from AIS brine seepage conditions
Zone F	1631.0	1628.3			Potential brine seepage interval-inferred from AIS brine seepage conditions
Zone G	1628.3	1626.3			Potential brine seepage interval-inferred from AIS brine seepage conditions
Zone H	1626.3	1620.8			Potential brine seepage interval-inferred from AIS brine seepage conditions
MB 129	1620.8	1619.0		x	Potential brine seepage interval- inferred from AIS seepage conditions. Clay at base (1/4" thick)
Zone I	1619.0	1614.0			Potential brine seepage interval-inferred from AIS brine seepage conditions
MB 130	1609.0	1608.3		x	Clay at base (1" thick)
MB 131	1541.5	1540.3			
Zone J	1540.3	1536.0			Potential brine seepage interval-inferred from AIS brine seepage conditions
MB 132	1510.2	1509.4			
MB 133	1491.9	1488.6			
MB 134	1446.5	1434.7			
MB 135	1419.0	1418.2			
MB 136	1374.3	1363.4			
MB 137	1349.8	1348.9			
MB 138	1302.6	1302.1			
Anhydrite "a" (ANH "a")	1279.6	1278.9			

WIPP Sealing System Design Report

Stratigraphic Unit/Engineering Feature	Unit/feature Top (ft-msl)	Unit/Feature Bottom (ft-msl)	Water/Brine Obs.	Clay Obs.	Comments
Anhydrite "b" (ANH "b")	1272.1	1271.8			
Station Level	1262.5	1252.0			Elevation 1252.00 ft-msl calculated from Bechtel drawings (level 2157.00 ft) Approximate-Bechtel Drawing 35-R-001-01D Rev. B, Exhaust Shaft 351 Development Plan Sections & Detail.
					MB-139 thru 142 were not penetrated by the exhaust shaft.

WIPP Sealing System Design Report

A.4.3 Salt Handling Shaft Stratigraphic Database

Stratigraphic Unit/Engineering Feature	Unit/Feature Top (ft-msl)	Unit/Feature Bottom (ft-msl)	Water/Brine Obs.	Clay Obs.	Comments
Top of Concrete	3411.5				Bechtel Drawing 37-R-010 Rev. A, Exploratory Shaft Key and Shaft Station Location Section (Top of Existing Shaft)
Ground Surface (SURF)/Finished Grade	3410.5				Ground surface (finished grade) elevation is tied to CWI benchmark No. CW-1 outside the exploratory shaft at an elevation of 3410.080 ft MSL; DOE-WIPP 86-010. Stratigraphic contacts are from lithologic log; TME 3178.
Quaternary Sd (QSD)	3410.5	3399.0			Stratigraphic units behind casing were not mapped. Mapping started in the basal portion of the Santa Rosa Fm. . Unit tops behind casing are secured from gamma ray log interpretation and the Bechtel drill log. DOE- WIPP-86-010.
Mescalero Caliche (MES)	3399.0	3394.5			
Gatuna Fm. (GAT)	3394.5	3374.0			
Santa Rosa Fm. (SR)	3374.0	3319.0			
Dewey Lk. Rb. (DLR)	3319.0	2868.0			Top contact is an erosional surface. Contact secured through gamma ray log interpretation.
Rustler Fm. (RUS)	2868.0	2560.0			Total inflow from rustler aquifers was less than 1.5 gallons per minute prior to liner installation. Subsequent to liner installation inflow rate dropped to less than 0.1 gallon per minute. TME 3178
49-er mbr (49R)	2868.0	2808.0	x		Groundwater, regional aquitard; at some locations a thin claystone has a transmissivity comparable to the Magenta. SAND90-2035J
Magenta mbr (MAG)	2808.0	2789.0	x		Groundwater, regional; SAND90-2035J
Tamarisk mbr (TAM)	2789.0	2711.0	x		Groundwater, regional aquitard; SAND90-2035J
Culebra D mbr (CUL)	2711.0	2694.0	x		Groundwater, regional; SAND90-2035J
Unnamed L mbr (ULM)	2694.0	2560.0	x		Groundwater, regional aquitard (siltstone unit at H-16); SAND90-2035J

WIPP Sealing System Design Report

Stratigraphic Unit/Engineering Feature	Unit/Feature Top (ft-msl)	Unit/Feature Bottom (ft-msl)	Water/Brine Obs.	Clay Obs.	Comments
Salado Fm. (SAL)	2560.0	*	x		Regional potential for Groundwater (brine) occurrence at the Rustler /Salado Fm. contact; SAND90-2035J. Groundwater seeps at Fm. contact noted on lithologic log; TME-3178. Shaft did not penetrate base of unit.
Key (See Comments)		2529.0			Elevation 2529.00 ft.-msl calculated from level 880.00 ft. Bechtel Drawing 37-R-012 Rev. A, Exploratory Shaft Key Sections and Details
MB 100	2488.0	*			Top from stratigraphic survey ; WTSD-TME-3179
MB 101	2439.1	2435.1			
MB 102	2400.0	2398.7		x	Clay at base
MB 103	2386.4	2372.6		x	Potential brine seepage interval-inferred from AIS brine seepage conditions. Clay at base.
MB 104	2364.6	2363.9			
MB 105	2348.2	2347.8		x	Clay at base
MB 106	2328.7	2327.3		x	Clay at base
MB 107	2294.0	2293.3		x	Clay at base
MB 108	2284.8	2283.9		x	Clay at base
MB 109	2263.5	2237.0		x	Potential brine seepage interval-inferred from AIS brine seepage conditions. Interbedded Clay
MB 110	2205.4	2204.3		x	Clay at base
MB 111	2189.1	2188.2			
MB 112	2171.6	2168.9		x	Clay at base
MB 113	2144.4	2142.6		x	Clay at base
MB 114	2120.7	2120.0			
MB 115	2084.5	2081.8		x	Clay at base
MB 116	2073.5	2071.0		x	Clay at base
Vaca Triste (VACA TR.)	2061.8	2060.0			Potential brine seepage interval-inferred from AIS brine seepage conditions
MB 117	1994.2	1993.3		x	Clay at base
MB 118	1965.5	1963.0			
MB 119	1945.1	1943.3		x	
MB 120	1925.5	1924.4		x	Clay at base

WIPP Sealing System Design Report

Stratigraphic Unit/Engineering Feature	Unit/Feature Top (ft-msl)	Unit/Feature Bottom (ft-msl)	Water/Brine Obs.	Clay Obs.	Comments
Zone A	1923.0	1913.8			Potential brine seepage interval-inferred from AIS brine seepage conditions
MB 121	1913.7	1911.5		x	Potential brine seepage interval-inferred from AIS brine seepage conditions. Clay at base.
MB 122	1903.7	1902.4			
Union Anhydrite	1874.5	1870.5			Potential brine seepage interval-inferred from AIS brine seepage conditions
MB 123	1791.8	1789.6			
MB 124	1783.8	1776.4		x	Potential brine seepage interval-inferred from AIS brine seepage conditions. Clay at base.
Zone B	1732.5	1729.3			Potential brine seepage interval-inferred from AIS brine seepage conditions
Zone C	1705.0	1696.3			Potential brine seepage interval-inferred from AIS brine seepage conditions
MB 125	1724.6	1722.9		x	Clay at base
MB 126	1688.2	1687.1		x	Clay - total section
MB 127	1662.3	1659.3		x	Clay at base
MB 128	1649.6	1648.2		x	Clay at base
Zone D	1639.5	1637.0			Potential brine seepage interval-inferred from AIS brine seepage conditions
Zone E	1637.0	1634.3			Potential brine seepage interval-inferred from AIS brine seepage conditions
Zone F	1634.3	1632.1			Potential brine seepage interval-inferred from AIS brine seepage conditions
Zone G	1632.1	1630.0			Potential brine seepage interval-inferred from AIS brine seepage conditions
Zone H	1630.0	1625.0			Potential brine seepage interval-inferred from AIS brine seepage conditions
MB 129	1625.0	1622.9		x	Clay at base
Zone I	1621.8	1613.0			Potential brine seepage interval-inferred from AIS brine seepage conditions
MB 130	1613.5	1612.5			Correlated with Air Intake and Exhaust Shafts.
MB 131	1545.5	1544.6			
Zone J	1544.6	1540.0			Potential brine seepage interval-inferred from AIS brine seepage conditions
MB 132	1511.1	1510.7		x	Clay - total section

WIPP Sealing System Design Report

Stratigraphic Unit/Engineering Feature	Unit/Feature Top (ft-msl)	Unit/Feature Bottom (ft-msl)	Water/Brine Obs.	Clay Obs.	Comments
MB 133	Absent	Absent			Pinched out.
MB 134	1453.7	1442.3		x	Clay at base
MB 135	1425.7	1424.2		x	Clay at top
MB 136	1382.3	1374.4		x	Clay at base
MB 137	1358.7	1357.5			
MB 138	1311.8	1311.1		x	Clay at base
Anhydrite "a" (ANH "a")	1288.4	1287.1		x	Clay at base
Anhydrite "b" (ANH "b")	1281.6	1280.7		x	Clay at base
Station Level		1247.0			Elevation 1247.00 ft.-msl calculated from level 2162.00 ft. (approximate) - Bechtel Drawing 37-R-010 Rev. A, Exploratory Shaft Key and Shaft Station Location Section. This level measurement needs to be confirmed with new measurement
					as it locates the station level below Marker Bed 139.
MB 139	1254.3	1252.3		x	Potential brine seepage interval - Anhydrite. Clay at base.
					Base of lithologic log terminates above MB 140. Total depth elevation is 1105.0 ft. msl.
MB 140					Potential brine seepage interval - Anhydrite

A.4.4 Waste Shaft Stratigraphic Database

Stratigraphic Unit/Engineering Feature	Unit/feature Top (ft-msl)	Unit/Feature Bottom (ft-msl)	Water/Brine Obs.	Clay Obs.	Comments
Top of Concrete	3408.5				Bechtel drawing 31-R-001-01D Rev. B, Waste Shaft 311 Development Sections (Top of Pad)
Ground Surface (SURF) /Finished Grade	3407.5				Ground surface (finish grade) elevation 3407.5 ft MSL, surveyed. Upper section of the shaft was not logged lithologically. Logging started at 3310.2 ft msl in the Dewey Lake Red Beds. Stratigraphic contacts are from lithologic log; WTSD-TME-038
Quaternary Sd (QSD)	3407.5				
Mescalero Caliche (MES)	Not mapped	Not mapped			
Gatuna Fm. (GAT)	Not mapped	Not mapped			
Santa Rosa Fm. (SR)	Not mapped	Not mapped			
Dewey Lk. Rb. (DLR)		2871.5		x	Top contact is an erosional surface. Clay (<6" thick)
Rustler Fm. (RUS)	2871.5	2565.3			
49-er mbr (49R)	2871.5	2813.0	x		Groundwater, regional aquitard; at some locations a thin claystone has a transmissivity comparable to the Magenta. SAND90-2035J
Magenta D mbr (MAG)	2813.0	2788.0	x		Groundwater; SAND90-2035J. Weeps WTSD - TME - 038
Tamarisk mbr (TAM)	2788.0	2702.5	x	x	Groundwater, regional aquitard; SAND90-2035J Thin clay layers (< 6" thick)
Culebra D mbr (CUL)	2702.5	2680.7	x		Groundwater, regional; DOE-WIPP 90-051
Unnamed L mbr (ULM)	2680.7	2565.3	x	x	Groundwater, regional aquitard (siltstone unit at H-16); SAND90-2035J, Thin clay layers (< 6" thick)
Salado Fm. (SAL)	2565.3	Did not penetrate	x		Regional potential for Groundwater (brine) occurrence at the Rustler /Salado Fm. contact; SAND90-2035J. No Groundwater at Fm. contact noted on lithologic log. Shaft did not penetrate base of unit.

WIPP Sealing System Design Report

Stratigraphic Unit/Engineering Feature	Unit/feature Top (ft-msl)	Unit/Feature Bottom (ft-msl)	Water/Brine Obs.	Clay Obs.	Comments
Key (See Comments)		2509.0			Elevation 2509.00 ft.-msl calculated from level 900.00 ft. Bechtel drawing 31-R-001-01D Rev. B, Waste Shaft 311 Development Sections and 31-R-002-01D Rev. A, Waste shaft 311 Shaft Lining and Key Section and Details
MB 100	*	*			Not marked on log
MB 101	2444.0	2442.0			
MB 102	2402.0	2401.0		x	Thin clay (<6" thick)
MB 103	2389.0	2374.0			Potential brine seepage interval-inferred from AIS brine seepage conditions
MB 104	2367.0	2366.0			
MB 105	2350.1	2349.0		x	Clay at base (<1" thick)
MB 106	2329.3	2328.5		x	Clay at base (<2" thick)
MB 107	2295.5	2295.0			
MB 108	2285.9	2285.3		x	Clay at base (<0.5" thick)
MB 109	2262.9	2236.9		x	Potential brine seepage interval-inferred from AIS brine seepage conditions. 1 ft. clay in middle of section
MB 110	2199.3	2196.0			
MB 111	2188.3	2188.0			
MB 112	2170.8	2168.5		x	Clay at base (<2" thick)
MB 113	2144.0	2142.3		x	Clay at base (<0.5" thick)
MB 114	2120.5	2119.5			
MB 115	2084.8	2081.5			
MB 116	2071.8	2069.0		x	Clay at base (<0.5" thick)
Vaca Triste (VACA TR.)	2060.5	2052.5			Potential brine seepage interval-inferred from AIS brine seepage conditions
MB 117	1993.2	1992.0		x	Clay at base (<3" thick)
MB 118	1969.8	1967.5		x	Clay at base (<0.5" thick)
MB 119	Absent	Absent			Section absent (pinched out).
MB 120	Absent	Absent			Section absent (pinched out).
Zone A	1923.8	1910.0			Potential brine seepage interval-inferred from AIS brine seepage conditions
MB 121	1910.0	1907.1		x	Potential brine seepage interval-inferred from AIS brine seepage conditions
MB 122	1900.3	1899.0			
Union Anhydrite	1874.3	1867.0			Potential brine seepage interval-inferred from AIS brine seepage conditions

WIPP Sealing System Design Report

Stratigraphic Unit/Engineering Feature	Unit/feature Top (ft-msl)	Unit/Feature Bottom (ft-msl)	Water/Brine Obs.	Clay Obs.	Comments
MB 123	1794.0	1787.0			
MB 124	1780.2	1771.5		x	Potential brine seepage interval - inferred from AIS brine seepage conditions. Clay at base (< 0.5' thick)
Zone B	1725.8	1720.3			Potential brine seepage interval-inferred from AIS brine seepage conditions
Zone C	1701.0	1691.0			Potential brine seepage interval-inferred from AIS brine seepage conditions
MB 125	Absent	Absent			Section absent (pinched out).
MB 126	1682.2	1681.2		x	Clay at base (<4" thick)
MB 127	1655.7	1653.5			
MB 128	1644.2	1642.2			
Zone D	1634.5	1632.5			Potential brine seepage interval-inferred from AIS brine seepage conditions
Zone E	1632.5	1630.0			Potential brine seepage interval-inferred from AIS brine seepage conditions
Zone F	1630.0	1627.0			Potential brine seepage interval-inferred from AIS brine seepage conditions
Zone G	1627.0	1625.0			Potential brine seepage interval-inferred from AIS brine seepage conditions
Zone H	1625.0	1619.5			Potential brine seepage interval-inferred from AIS brine seepage conditions
MB 129	1619.5	1617.7		x	Clay at base (1 ft. thick)
Zone I	1616.5	1612.3			Potential brine seepage interval-inferred from AIS brine seepage conditions
MB 130	1608.1	1606.9			
MB 131	1539.3	1538.5		x	Thin clay layer at base.
Zone J	1538.0	1531.0			Potential brine seepage interval-inferred from AIS brine seepage conditions
MB 132	1508.0	1507.0		x	Clay at base (<0.5" thick)
MB 133	1489.8	1487.7		x	Thin clay layer at base.
MB 134	1445.3	1433.5		x	Clay at base (<4" thick)
MB 135	1417.2	1411.5			
MB 136	1373.3	1362.1		x	Thin clay layer at base.
MB 137	Absent	Absent			Section absent (pinched out).
MB 138	1299.5	1289.9		x	Clay at base (<1.5" thick)
Anhydrite "a" (ANH "a")	1276.1	1275.3		x	Clay at base (<0.25" thick)

WIPP Sealing System Design Report

Stratigraphic Unit/Engineering Feature	Unit/feature Top (ft-msl)	Unit/Feature Bottom (ft-msl)	Water/Brine Obs.	Clay Obs.	Comments
Anhydrite "b" (ANH "b")	1268.6	1268.4		x	Clay at base (<0.25" thick)
Station Level	1259.0	1249.0			Elevation 1249.0 ft.-msl calculated from level 2160.0 ft. Bechtel drawing 31-R-001-01D Rev. B, Waste Shaft 311 Development Sections
					MB-139 thru 142 were not noted on lithologic log.
MB 139					Potential brine seepage interval - Anhydrite
MB 140					Potential brine seepage interval - Anhydrite

A.5 Conclusions

The evaluation of shaft stratigraphy and geohydrology at the WIPP has provided extensive information about shaft stratigraphy, shaft groundwater/brine occurrence, and shaft survey data. This information is outlined as follows:

A.5.1 Shaft Stratigraphy

- The SDB records the following information relevant to each shaft:
 - ◆ Engineering features (top of concrete, base of key, and station level)
 - ◆ Ground Surface (finished grade)
 - ◆ Stratigraphic unit contact name
 - ◆ Unit top MSL elevation
 - ◆ Unit bottom MSL elevation
 - ◆ Groundwater/brine observance
 - ◆ Clay observance
 - ◆ Comments relating to stratigraphic unit or engineering features.

The evaluation has

- confirmed the vertical and lateral continuity of the majority of the named stratigraphic units among the four shafts;
- identified occurrences of clay in marker beds (as logged during the geologic mapping of each shaft) that could serve as impermeable layers upon which brine may migrate, or in some instances, if the clay was buried prior to dewatering, the clay layer can yield some water as it dewateres and consolidates after being exposed subsequent to shaft construction (Deal et al., 1995).
- provided a graphical display in the form of structural cross sections, derived from the compiled data base, that illustrate the horizontal and vertical relationships of named stratigraphic units among the WIPP shafts.

A.5.2 Shaft Groundwater / Brine Occurrence

The evaluation of WIPP geohydrology performed to identify regional intervals of groundwater occurrence in the Rustler Formation and shallower stratigraphic units, as well as brine seepage intervals in the Salado Formation penetrated by the shafts

- identified regional groundwater occurrence intervals in the Rustler Formation as well as 19 intervals of brine seepage within the Salado Formation penetrated by the four shafts;
- identified intervals of brine seepage through recent observations (July 1994) of the Salado Formation in the AIS. Currently, the surface Marker Bed 103 is the only seepage interval where the salt encrustations are visibly wet;
- identified typical hydraulic conductivity values for the primary lithologies encountered in the Salado Formation section penetrated by the shafts;
- provided a graphical display in the form of structural cross sections, derived from the compiled data in the SDB, that illustrate the vertical and potential lateral distribution of brine seepage intervals within the Salado Formation.

WIPP Sealing System Design Report

A.5.3 Shaft Survey Data

The shaft survey data were reviewed to evaluate the MSL elevations secured from the shaft as-built drawings relative to those recorded in the SDB and to determine a surface reference point to facilitate completion of sealing system design drawings and final seal emplacement. This review

- demonstrated relative consistency (within 6 in.) between surface elevations reported in geotechnical reports and working drawings and the data recorded on the Bechtel and Westinghouse as-built drawings for each shaft;
- identified the WIPP surveyed reference level 0'-0" (elevation of 3409.0 ft-MSL) used for computing below-surface depths (i.e., 3409.0 ft-MSL = Reference level 0'-0");
- identified the "top of concrete" for each shaft as a consistent surface reference point to be utilized for the development of the shaft seal design drawings;
- identified discrepancies between lithologic data obtained from geotechnical shaft reports and as-built data, by comparing the shaft SDB elevations to shaft as-built drawing elevations.

A.6 References

- Beauheim, R.L. 1987. *Interpretations of Single-Well Hydraulic Tests Conducted At and Near the Waste Isolation Pilot Plant (WIPP) Site, 1983-1987*. SAND87-0039. Albuquerque, NM: Sandia National Laboratories.
- Beauheim, R.L., and R.M. Holt. 1990. "Hydrogeology of the WIPP Site," *Geological and Hydrological Studies of Evaporites in the Northern Delaware Basin for the Waste Isolation Pilot Plant (WIPP), New Mexico, Field Trip #14 Guidebook*, Geological Society of America 1990 Annual Meeting, Dallas, TX, October 20–November 1, 1990. Leaders: D.W. Powers, R.M. Holt, R.L. Beauheim, and N. Rempe. SAND90-2035J. Dallas, TX: Dallas Geological Society. pp. 131-179.
- Deal, D.E., R.J. Abitz, J.B. Case, M.E. Crawley, C.A. Givens, D.S. Belski, P.P. James Lipponer, D.J. Milligan, J. Myers, D.W. Powers, M.A. Valdivia. 1995. *Brine Sampling and Evaluation Program 1992-1993 Report and Summary of BSEP Data Since 1982*. DOE-WIPP 94-011. Carlsbad, NM: U.S. Department of Energy, Waste Isolation Pilot Plant.
- Holt, R.M., and D.W. Powers. 1984. *Geotechnical Activities in the Waste Handling Shaft Waste Isolation Pilot Plant (WIPP) Project Southeastern New Mexico*. WTSD-TME-038. Carlsbad, NM: U.S. Department of Energy, Waste Isolation Pilot Plant.
- Holt, R.M., and D.W. Powers. 1986. *Geotechnical Activities in the Exhaust Shaft*. DOE-WIPP 86-008. Carlsbad, NM: U.S. Department of Energy.
- Holt, R.M., and D.W. Powers. 1990. *Geologic Mapping of the Air Intake Shaft at the Waste Isolation Pilot Plant*. DOE-WIPP 90-051. Carlsbad, NM: Westinghouse Electric Corporation.
- Jarolimek, L., M.J. Timmer, and R.F. McKinney. 1983a. *Geotechnical Activities in the Exploratory Shaft – Selection of the Facility Interval Waste Isolation Pilot Plant (WIPP) Project, Southeastern New Mexico*. TME-3178. Albuquerque, NM: U.S. Department of Energy, Waste Isolation Pilot Plant.

WIPP Sealing System Design Report

- Jarolimek, L., M.J. Timmer, and D.W. Powers. 1983b. *Correlation of Drillhole and Shaft Logs. Waste Isolation Pilot Plant (WIPP) Project, Southeastern New Mexico*. WTSD-TME-3179. Albuquerque, NM: U.S. Department of Energy.
- Lappin, A.R., R.L. Hunter, D.P. Garber, and P.B. Davies, eds. 1989. *Systems Analysis, Long-Term Radionuclide Transport, and Dose Assessments, Waste Isolation Pilot Plant (WIPP), Southeastern New Mexico; March 1989*. SAND89-0462. Albuquerque, NM: Sandia National Laboratories
- Mercer, J.W., R.L. Beauheim, R.P. Snyder, and G.M. Fairer. 1987. *Basic Data Report for Drilling and Hydrologic Testing of Drillhole DOE-2 at the Waste Isolation Pilot Plant (WIPP) Site*. SAND86-0611. Albuquerque, NM: Sandia National Laboratories.
- Saulnier, G.J., Jr., and J.D. Avis. 1988. *Interpretation of Hydraulic Tests Conducted in the Waste-Handling Shaft at the Waste Isolation Pilot Plant (WIPP) Site*. SAND88-7001. Albuquerque, NM: Sandia National Laboratories.
- Stein, C.L., and J.L. Krumhansl. 1986. *Chemistry of Brines in Salt from the Waste Isolation Pilot Plant (WIPP), Southeastern New Mexico: A Preliminary Investigation*. SAND85-0897. Albuquerque, NM: Sandia National Laboratories.
- TSC-D'Appolonia. 1983. *Geologic Mapping and Water Inflow Testing in the SPDV Ventilation Shaft. Geotechnical Field Data Report No. 4*. WIPP-SPDV. [Albuquerque, NM D'Appolonia Consulting Engineers, Inc.] (Copy on file at the NWM Library: Sandia National Laboratories, Albuquerque, NM.)
- US DOE (Department of Energy). 1986. *Waste Isolation Pilot Plant Design Validation Final Report*. DOE-WIPP-86-010. San Francisco, CA: Bechtel National, Inc.
- Van Sambeek, L.L., D.D. Luo, M.S. Lin, W. Ostrowski, and D. Oyenuga. 1993. *Seal Design Alternatives Studies*. SAND92-7340. Albuquerque, NM: Sandia National Laboratories.

WIPP Sealing System Design Report

**Appendix B:
Shaft Sealing System Drawings**

WIPP Sealing System Design Report

STRATIGRAPHY
(SEE NOTE 1)

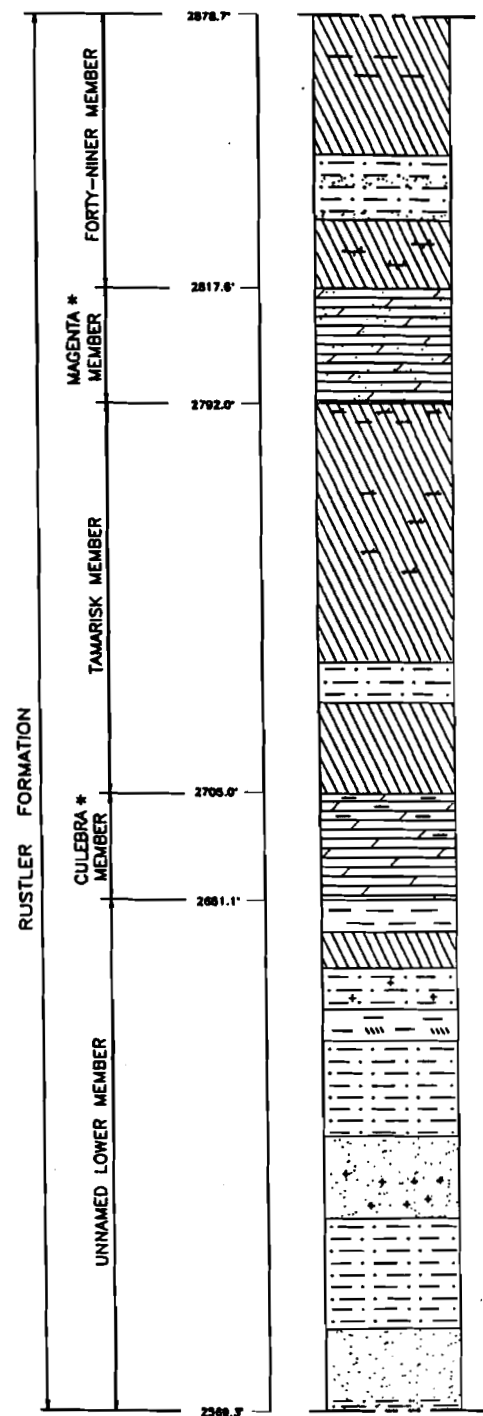
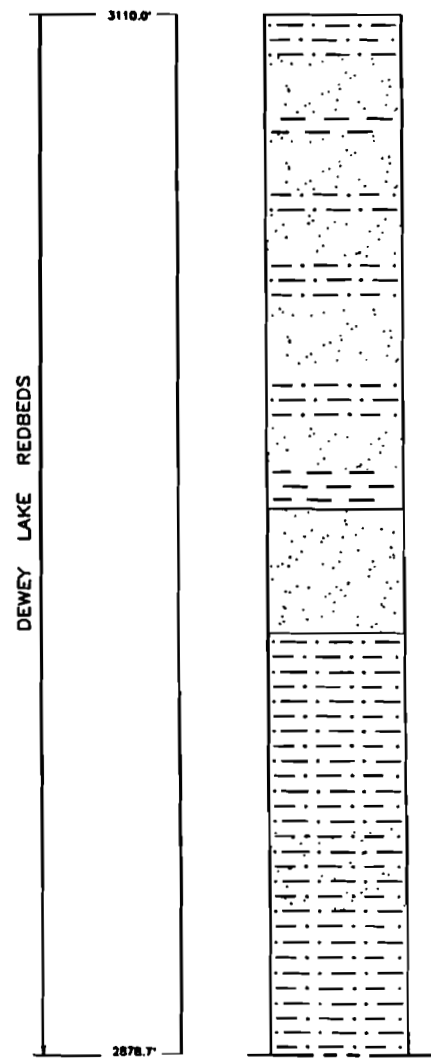
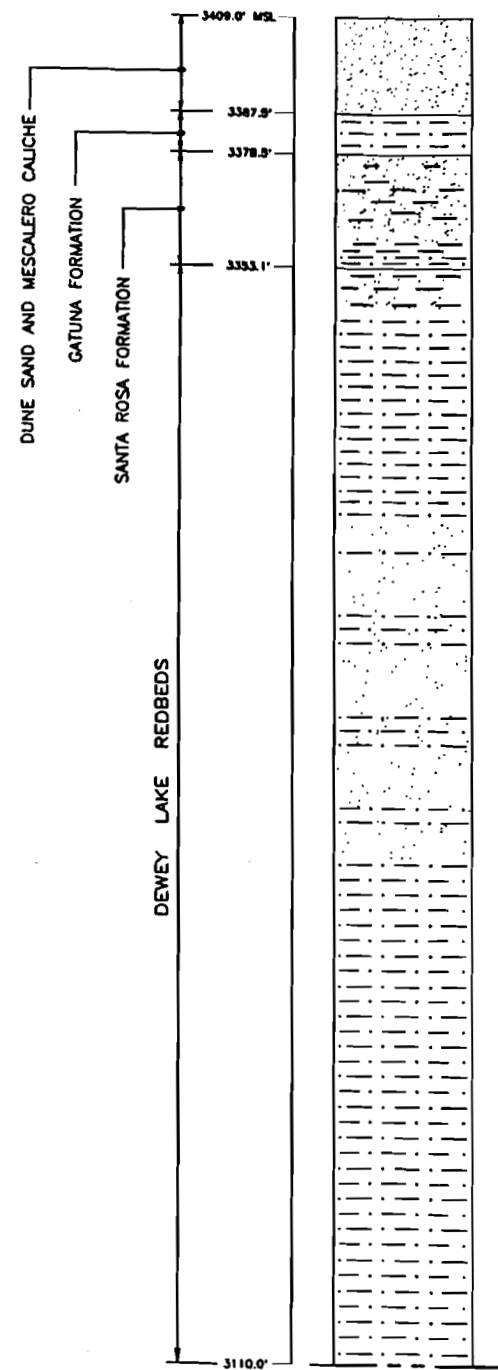

LITHOLOGY:

PRIMARY ROCK/SEDIMENT TYPES	SECONDARY CONSTITUENTS
[Symbol] MUDSTONE/CLAYSTONE	[Symbol] ARGILLACEOUS
[Symbol] CLAYSTONE BED	[Symbol] SILTY
[Symbol] SILTSTONE	[Symbol] SANDY
[Symbol] SANDSTONE	[Symbol] SULFATIC
[Symbol] ANHYDRITE/GYPSUM	[Symbol] DOLOMITIC
[Symbol] DOLOMITE	[Symbol] CALCAREOUS
[Symbol] HALITE	[Symbol] HALTIC
[Symbol] POLYHALITE	[Symbol] POLYHALITIC
	[Symbol] LANGBEINITE

NOTE:

1. THE STRATIGRAPHY AND GROUNDWATER BRINE SEEPAGE/WEEP INTERVALS ARE BASED ON THE LITHOLOGIC INFORMATION COMPILED DURING THE GEOLOGIC MAPPING OF THE AIR INTAKE SHAFT WALLS, DOE/WIPP-90-051, "GEOLOGIC MAPPING OF THE AIR INTAKE SHAFT AT THE WASTE ISOLATION PILOT PLANT", 1990, AND "LETTER REPORT ON THE RESULTS OF THE WASTE ISOLATION PILOT PLANT SHAFT STRATIGRAPHY CORRELATION PROJECT", 1994.

ASTERISK(*) INDICATES GROUNDWATER (RUSTLER/SUPRA RUSTLER FORMATIONS) OR BRINE SEEPAGE/WEEPS (SALADO FORMATION) OBSERVED DURING THE MAPPING OF THE AIR INTAKE SHAFT. AS OF 1994, ONLY MB103 SHOWED VISIBLE MOISTURE ON THE SALADO FORMATION SURFACE EXPOSED WITHIN THE AIR INTAKE SHAFT, "BRINE SAMPLING EVALUATION PROGRAM 1992-1993 REPORT," 1994, DOE-WIPP 94-011.

ABBREVIATION:

ANH.	ANHYDRITE
COL.	COLUMN
CONC.	CONCRETE
D	DIAMETER
DET.	DETAIL
DOE	DEPARTMENT OF ENERGY
DWG.	DRAWING
EL.	ELEVATION
EXIST.	EXISTING
MSL	MEAN SEA LEVEL
TYP.	TYPICAL
VACA TR.	VACA TRISTE
WID	WESTINGHOUSE WASTE ISOLATION DIVISION
WIPP	WASTE ISOLATION PILOT PLANT

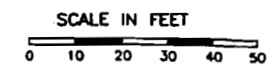

REV.	DATE	DESCRIPTION	BY	CK.	APP.
SANDIA NATIONAL LABORATORIES					
WIPP A/E SUPPORT				CONTRACT NO: AG-4909	
WIPP SHAFT SEALING SYSTEM NEAR-SURFACE/RUSTLER FORMATIONS			NAME	DATE	
			BY	10/1/94	
			CK.	[Signature]	
			APP.	[Signature]	
			APP.	[Signature]	
AIR INTAKE SHAFT STRATIGRAPHIC PROFILE					
PARSONS BRINCKERHOFF ENERGY SERVICES, INC		SCALE:	SIZE	SNL DWG. NO.	SHEET NO.
			8	33-SNL-003	1 OF 2

Figure B-1.

STRATIGRAPHY
(SEE NOTE 1 OF SHEET NO. 1)

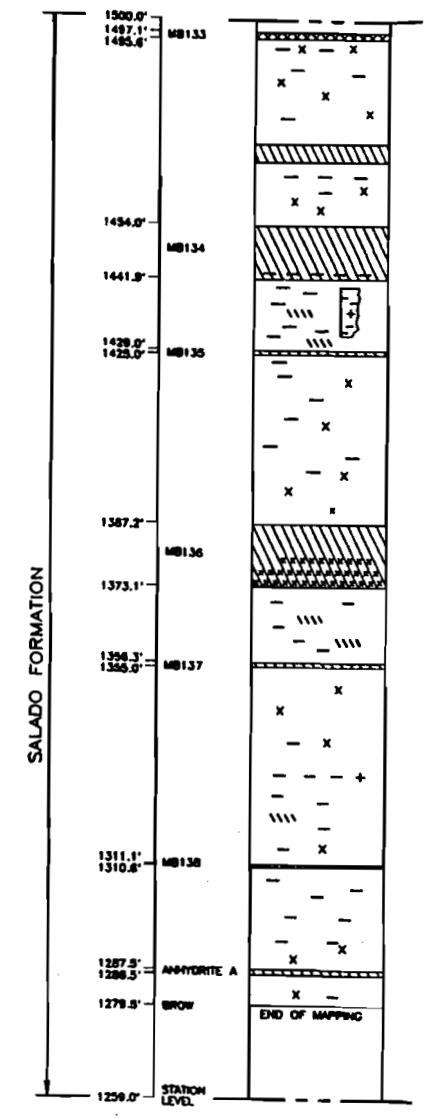
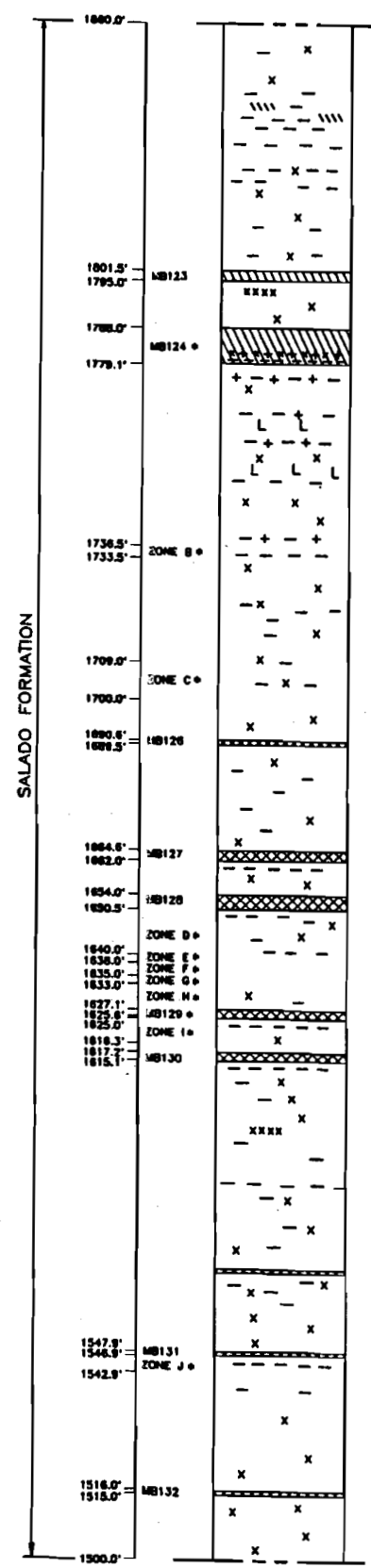
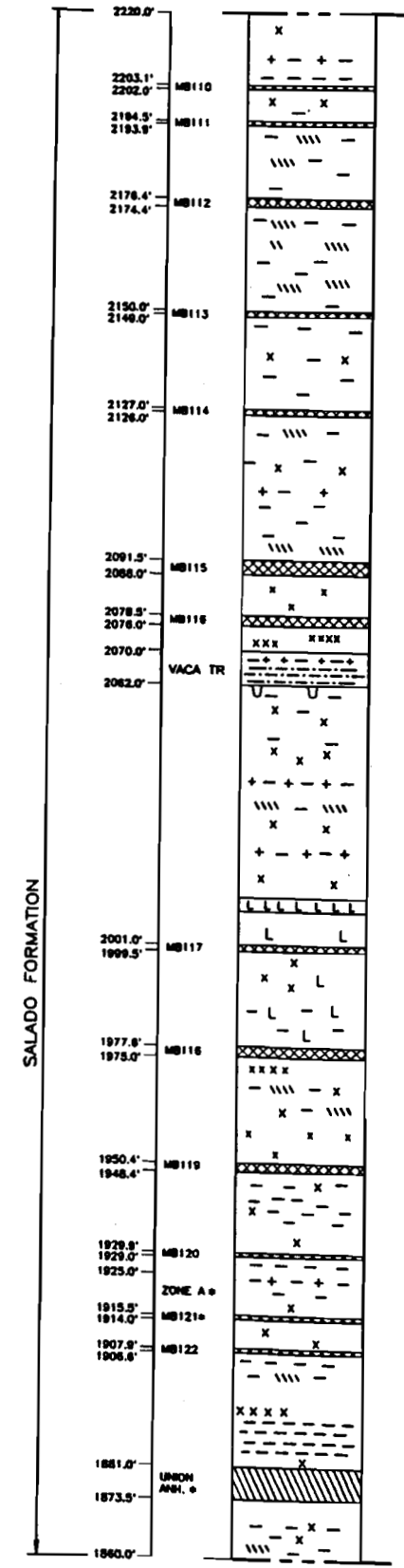
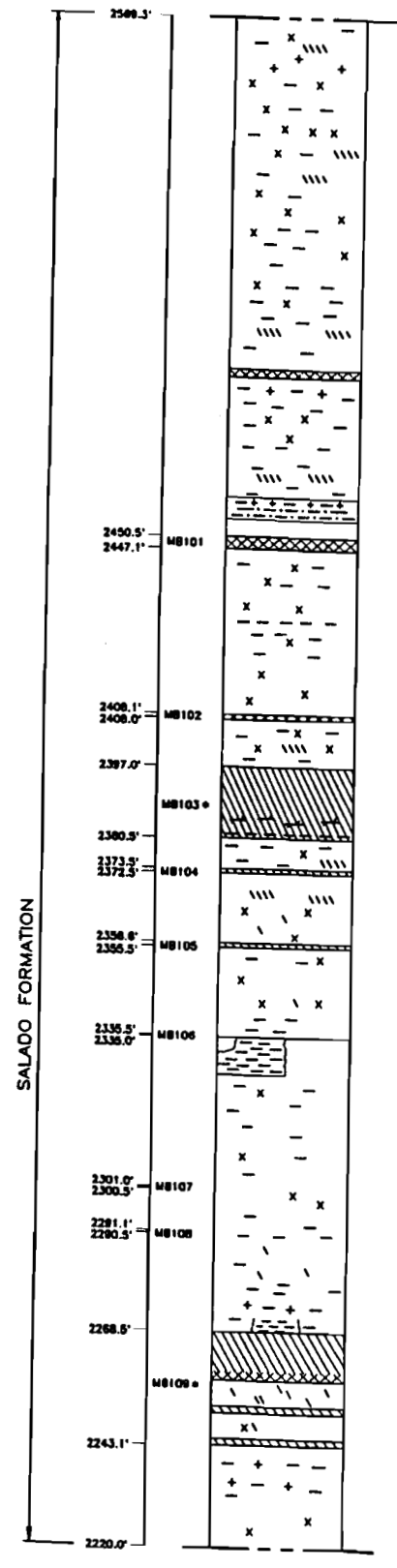

- LITHOLOGY:**
- PRIMARY ROCK/SEDIMENT TYPES**
- MUDSTONE/CLAYSTONE
 - CLAYSTONE BED
 - SILTSTONE
 - SANDSTONE
 - ANHYDRITE/GYPSUM
 - DOLOMITE
 - HALITE
 - POLYHALITE
- SECONDARY CONSTITUENTS**
- ARGILLACEOUS
 - SILTY
 - SANDY
 - SULFATIC
 - DOLOMITIC
 - CALCAREOUS
 - HALITIC
 - POLYHALITIC
 - LANGBEINITE

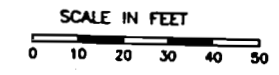

REV.	DATE	DESCRIPTION	BY	CK.	APP.
SANDIA NATIONAL LABORATORIES					
WIPP A/E SUPPORT					
WIPP SHAFT SEALING SYSTEM				CONTRACT NO: AC-4009	
SALADO FORMATION				NAME _____ DATE _____	
AIR INTAKE SHAFT					
STRATIGRAPHIC PROFILE					
BY: <i>[Signature]</i>				DATE: <i>[Date]</i>	
CK: <i>[Signature]</i>				APP: <i>[Signature]</i>	
APP: <i>[Signature]</i>				APP: <i>[Signature]</i>	
PARSONS BRINCKERHOFF ENERGY SERVICES, INC		SCALE: SIZE B	SNL DWG. NO. 33-SNL-003	SHEET NO. 2 OF 2	

Figure B-2.

STRATIGRAPHY
(SEE NOTE 2)

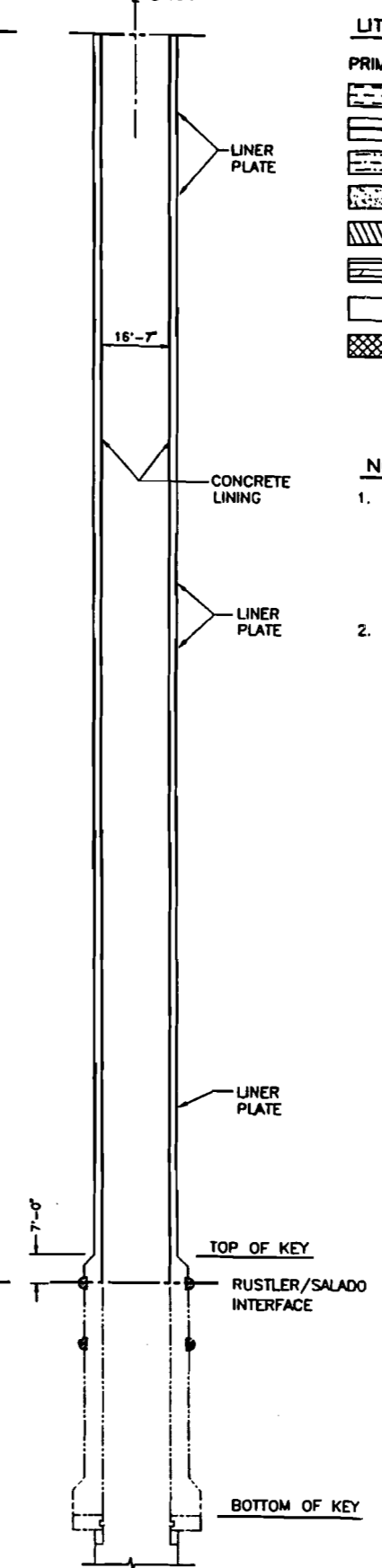
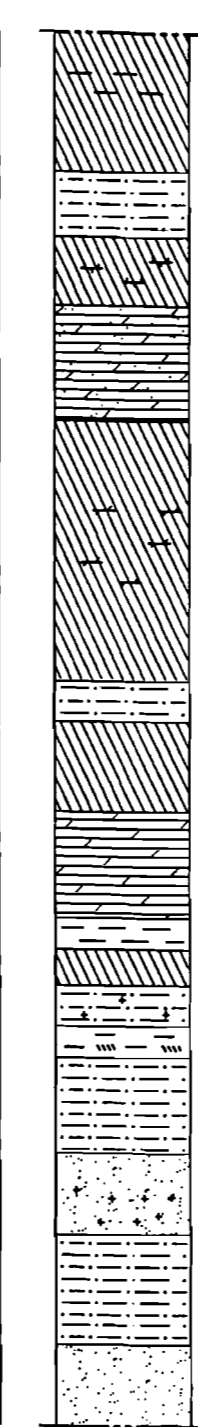
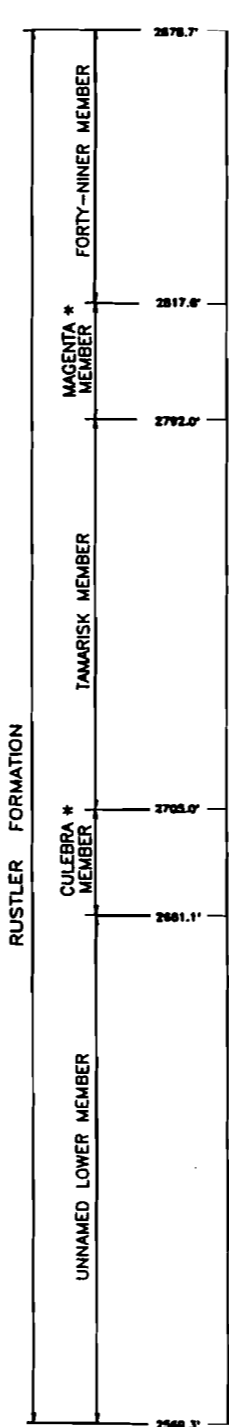
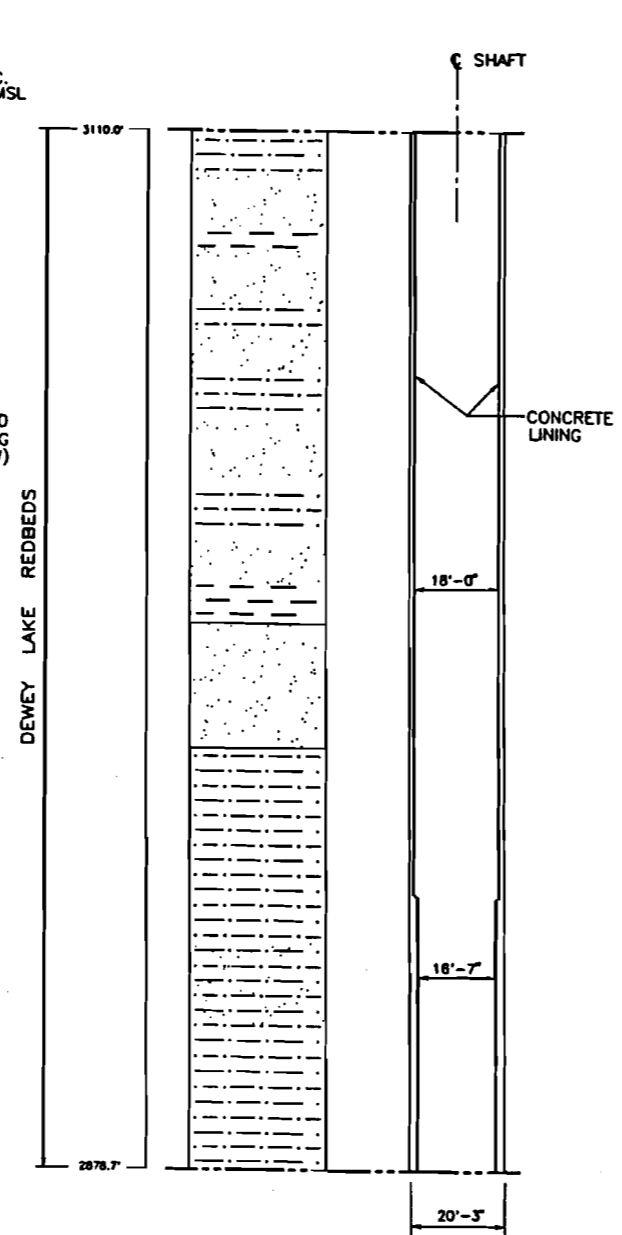
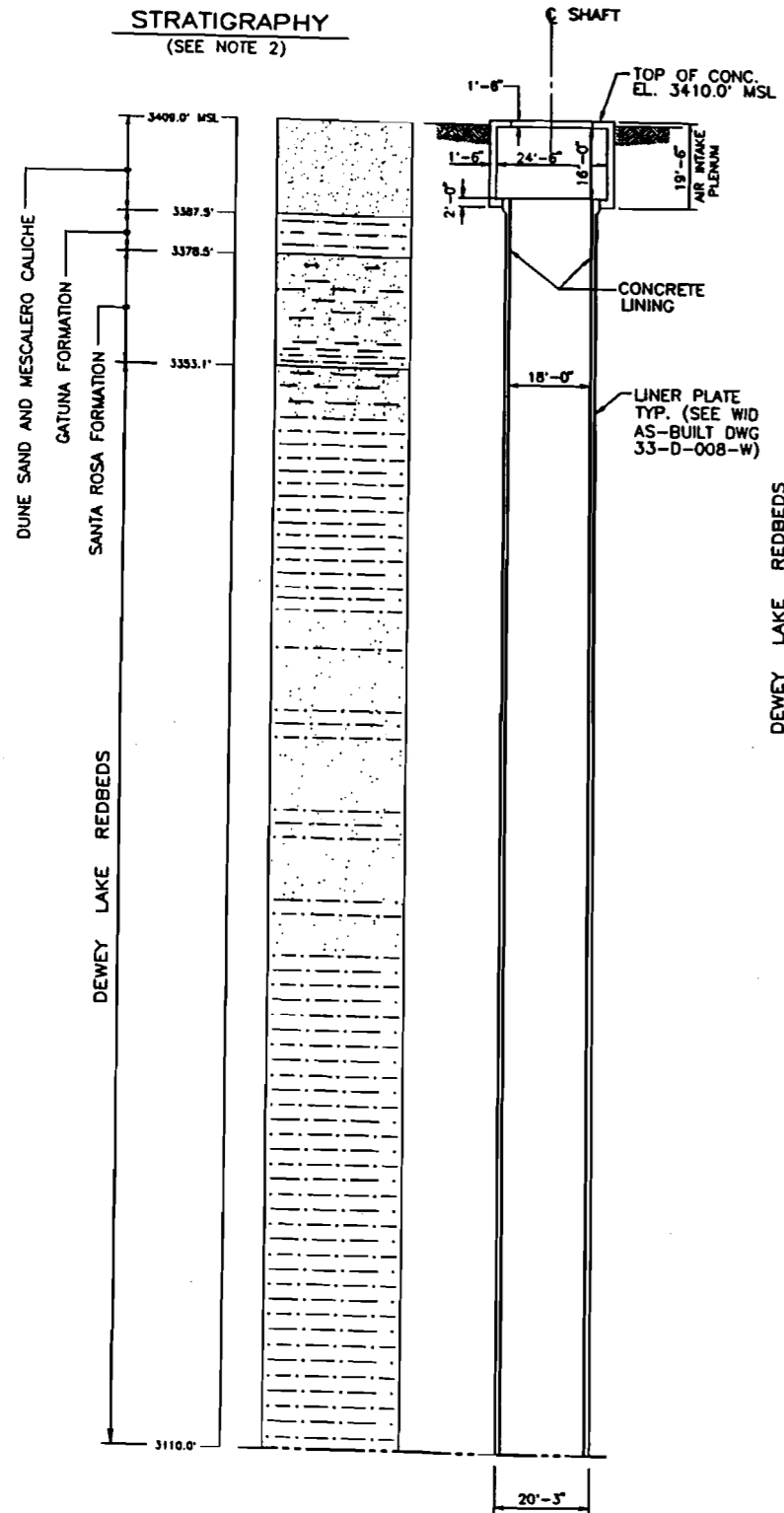

LITHOLOGY:

PRIMARY ROCK/SEDIMENT TYPES	SECONDARY CONSTITUENTS
[Symbol] MUDSTONE/CLAYSTONE	[Symbol] ARGILLACEOUS
[Symbol] CLAYSTONE BED	[Symbol] SILTY
[Symbol] SILTSTONE	[Symbol] SANDY
[Symbol] SANDSTONE	[Symbol] SULFATIC
[Symbol] ANHYDRITE/GYPSUM	[Symbol] DOLOMITIC
[Symbol] DOLOMITE	[Symbol] CALCAREOUS
[Symbol] HALITE	[Symbol] HALITIC
[Symbol] POLYHALITE	[Symbol] POLYHALITIC
	[Symbol] LANGBEINITE

NOTE:

- SHAFT COLLAR DETAILS BASED ON WESTINGHOUSE (WID) AS-BUILT DWGS. 33-C-001-W, DATED 1/22/93. AIR INTAKE SHAFT 331 SHAFT COLLAR/AIR INTAKE PLENUM PLAN, SECTIONS AND DETAILS AND 33-D-008-W, DATED 11/6/92, AIR INTAKE SHAFT 331 GENERAL ARRANGEMENT.
- THE STRATIGRAPHY AND GROUNDWATER BRINE SEEPAGE/WEEP INTERVALS ARE BASED ON THE LITHOLOGIC INFORMATION COMPILED DURING THE GEOLOGIC MAPPING OF THE AIR INTAKE SHAFT WALLS, DOE/WIPP-90-051, "GEOLOGIC MAPPING OF THE AIR INTAKE SHAFT AT THE WASTE ISOLATION PILOT PLANT", 1990, AND "LETTER REPORT ON THE RESULTS OF THE WASTE ISOLATION PILOT PLANT SHAFT STRATIGRAPHY CORRELATION PROJECT", 1994.

ASTERISK(*) INDICATES GROUNDWATER (RUSTLER/SUPRA RUSTLER FORMATIONS) OR BRINE SEEPAGE/WEEPS (SALADO FORMATION) OBSERVED DURING THE MAPPING OF THE AIR INTAKE SHAFT. AS OF 1994, ONLY MB103 SHOWED VISIBLE MOISTURE ON THE SALADO FORMATION SURFACE EXPOSED WITHIN THE AIR INTAKE SHAFT, "BRINE SAMPLING EVALUATION PROGRAM 1992-1993 REPORT," 1994, DOE-WIPP 94-011.

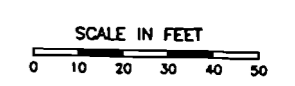

REV.	DATE	DESCRIPTION	BY	CK.	APP.
SANDIA NATIONAL LABORATORIES					
WIPP A/E SUPPORT					
WIPP SHAFT SEALING SYSTEM NEAR-SURFACE/RUSTLER FORMATIONS				CONTRACT NO: AG-4908	
AIR INTAKE SHAFT STRATIGRAPHY & AS-BUILT ELEMENTS				NAME DATE	
				BY: [Signature]	
				CK: [Signature]	
				APP: [Signature]	
				APP: [Signature]	
PARSONS BRINCKERHOFF ENERGY SERVICES, INC		SCALE: B	SIZE: B	SNL DWG. NO.: 33-SNL-004	SHEET NO.: 1 OF 2

Figure B-3.

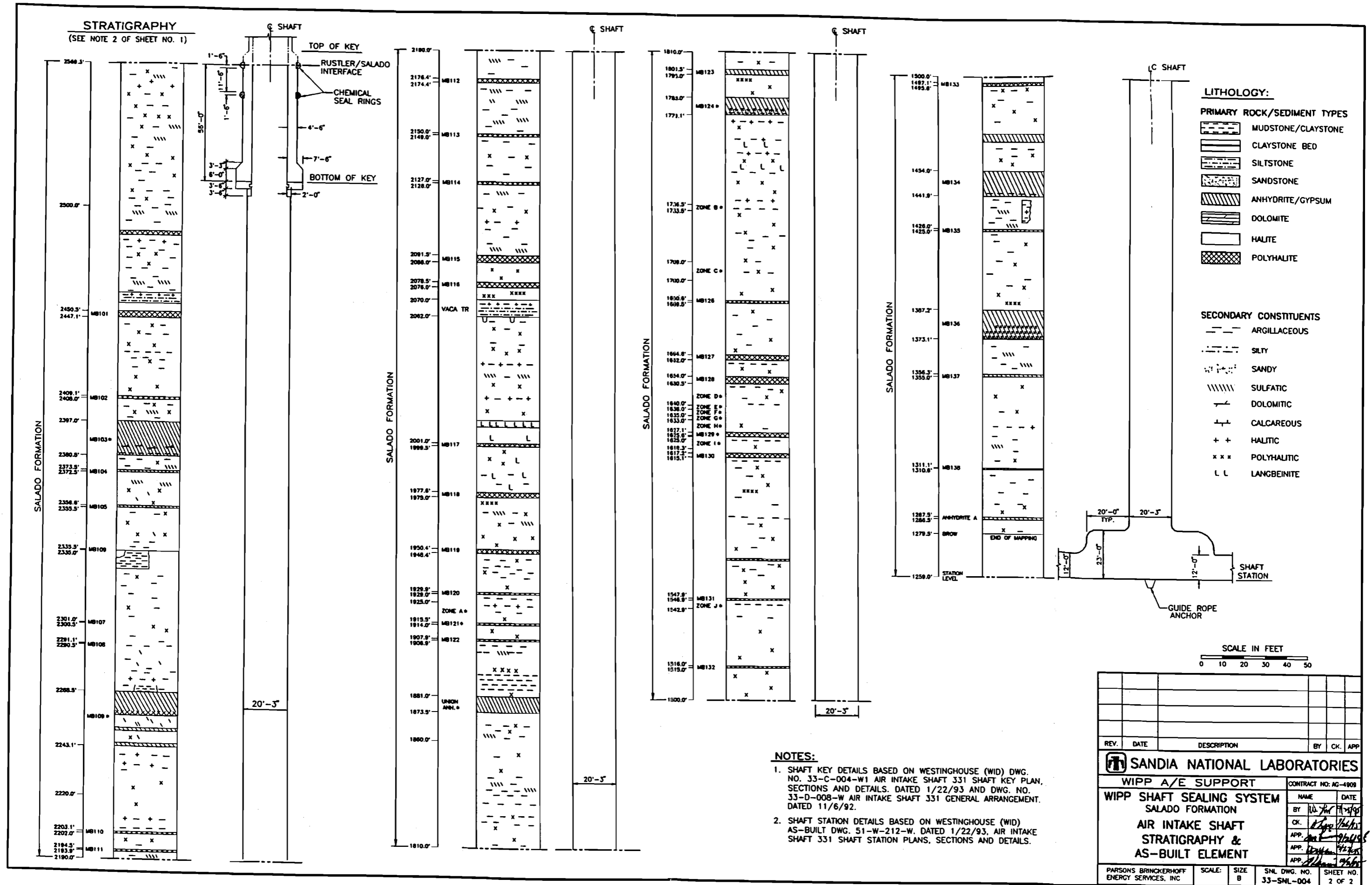
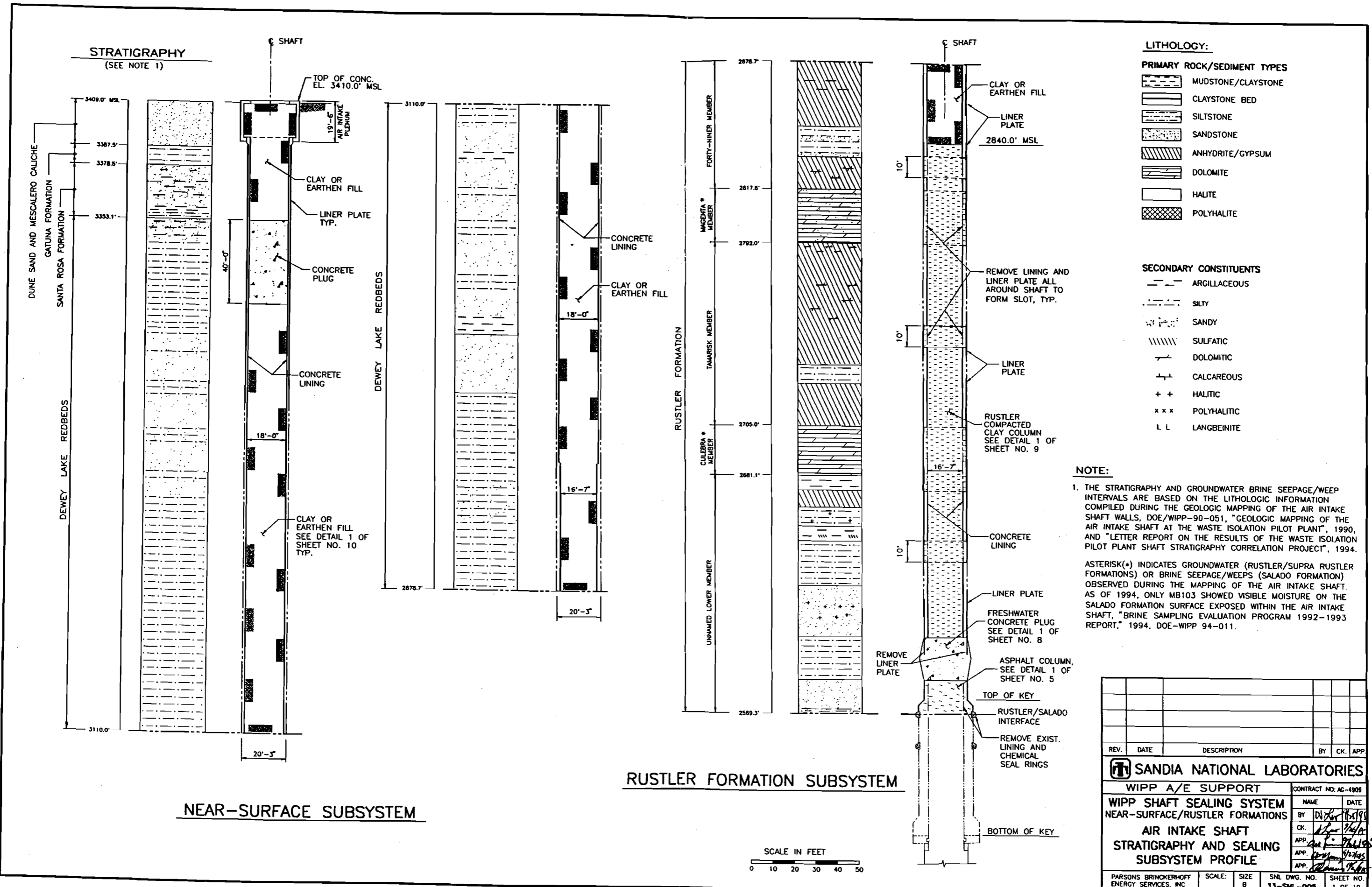

Figure B-4.



STRATIGRAPHY
(SEE NOTE 1)

LITHOLOGY:

- PRIMARY ROCK/SEDIMENT TYPES**
- MUDSTONE/CLAYSTONE
 - CLAYSTONE BED
 - SILTSTONE
 - SANDSTONE
 - ANHYDRITE/GYPSUM
 - DOLOMITE
 - HALITE
 - POLYHALITE

- SECONDARY CONSTITUENTS**
- ARGILLACEOUS
 - SILTY
 - SANDY
 - SULFATIC
 - DOLOMITIC
 - CALCAREOUS
 - HALITIC
 - POLYHALITIC
 - LANGBEINITE

NOTE:

1. THE STRATIGRAPHY AND GROUNDWATER BRINE SEEPAGE/WEEP INTERVALS ARE BASED ON THE LITHOLOGIC INFORMATION COMPILED DURING THE GEOLOGIC MAPPING OF THE AIR INTAKE SHAFT WALLS, DOE/WIPP-90-051, "GEOLOGIC MAPPING OF THE AIR INTAKE SHAFT AT THE WASTE ISOLATION PILOT PLANT", 1990, AND "LETTER REPORT ON THE RESULTS OF THE WASTE ISOLATION PILOT PLANT SHAFT STRATIGRAPHY CORRELATION PROJECT", 1994.

ASTERISK(*) INDICATES GROUNDWATER (RUSTLER/SUPRA RUSTLER FORMATIONS) OR BRINE SEEPAGE/WEEPS (SALADO FORMATION) OBSERVED DURING THE MAPPING OF THE AIR INTAKE SHAFT. AS OF 1994, ONLY MB103 SHOWED VISIBLE MOISTURE ON THE SALADO FORMATION SURFACE EXPOSED WITHIN THE AIR INTAKE SHAFT, "BRINE SAMPLING EVALUATION PROGRAM 1992-1993 REPORT," 1994, DOE-WIPP 94-011.

REV.	DATE	DESCRIPTION	BY	CK.	APP.

SANDIA NATIONAL LABORATORIES

WIPP A/E SUPPORT CONTRACT NO: AG-4909

WIPP SHAFT SEALING SYSTEM
NEAR-SURFACE/RUSTLER FORMATIONS

AIR INTAKE SHAFT
STRATIGRAPHY AND SEALING
SUBSYSTEM PROFILE

NAME	DATE
BY: <i>DN</i>	1/25/95
CK: <i>AP</i>	1/24/95
APP: <i>AP</i>	1/24/95
APP: <i>AP</i>	1/24/95
APP: <i>AP</i>	1/24/95

PARSONS BRINCKERHOFF ENERGY SERVICES, INC. SCALE: SIZE B SNL DWG. NO. 33-SNL-005 SHEET NO. 1 OF 10

RUSTLER FORMATION SUBSYSTEM

NEAR-SURFACE SUBSYSTEM

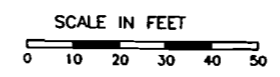
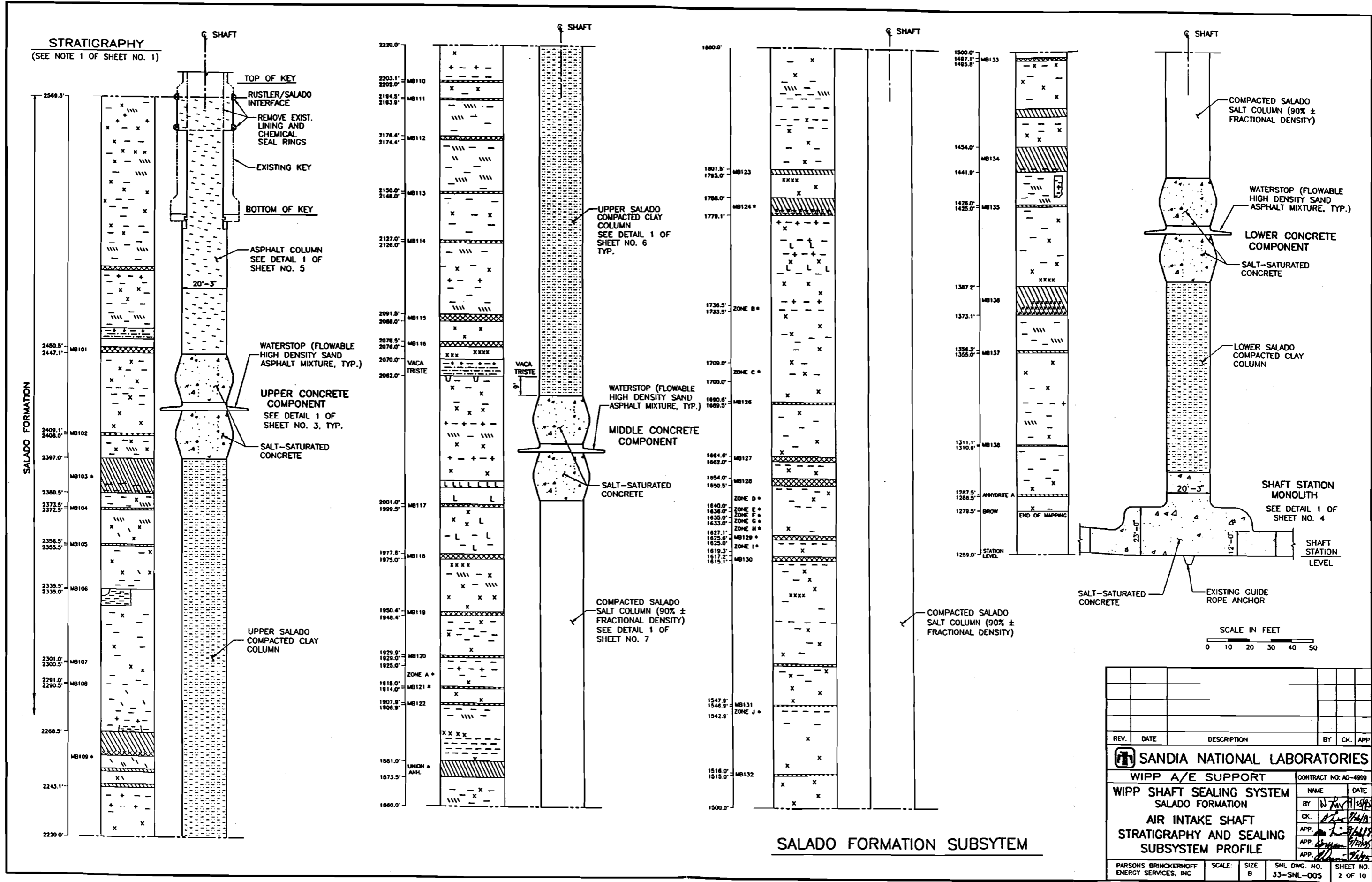
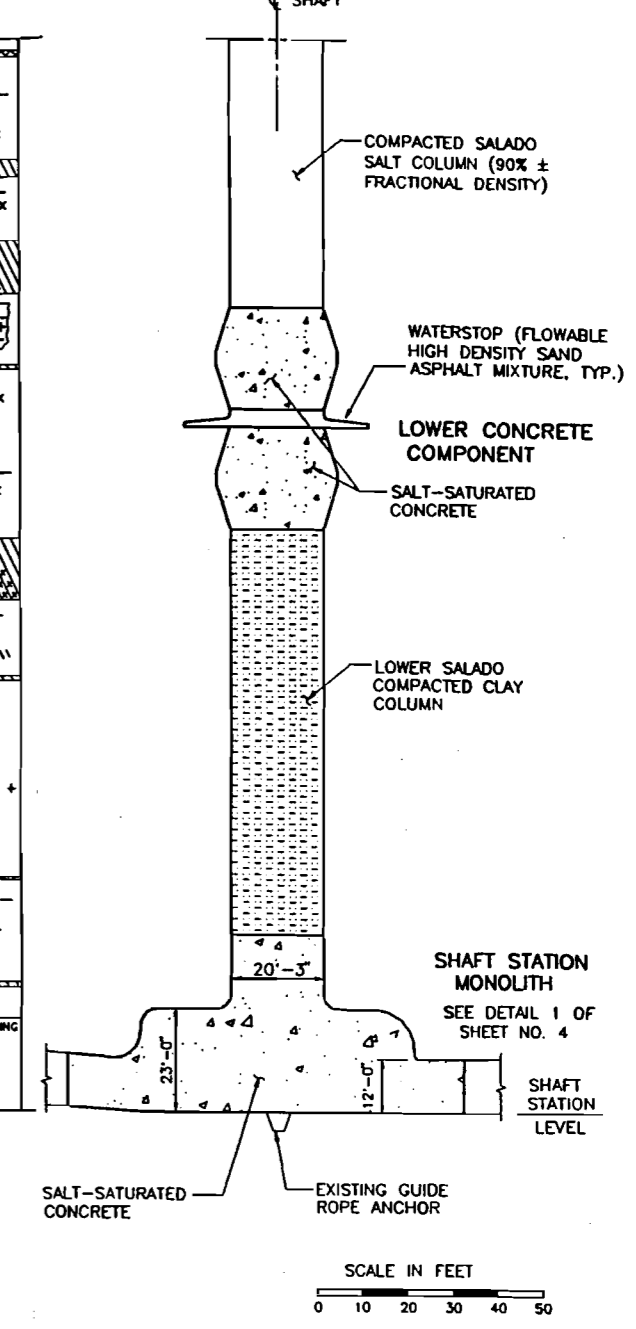
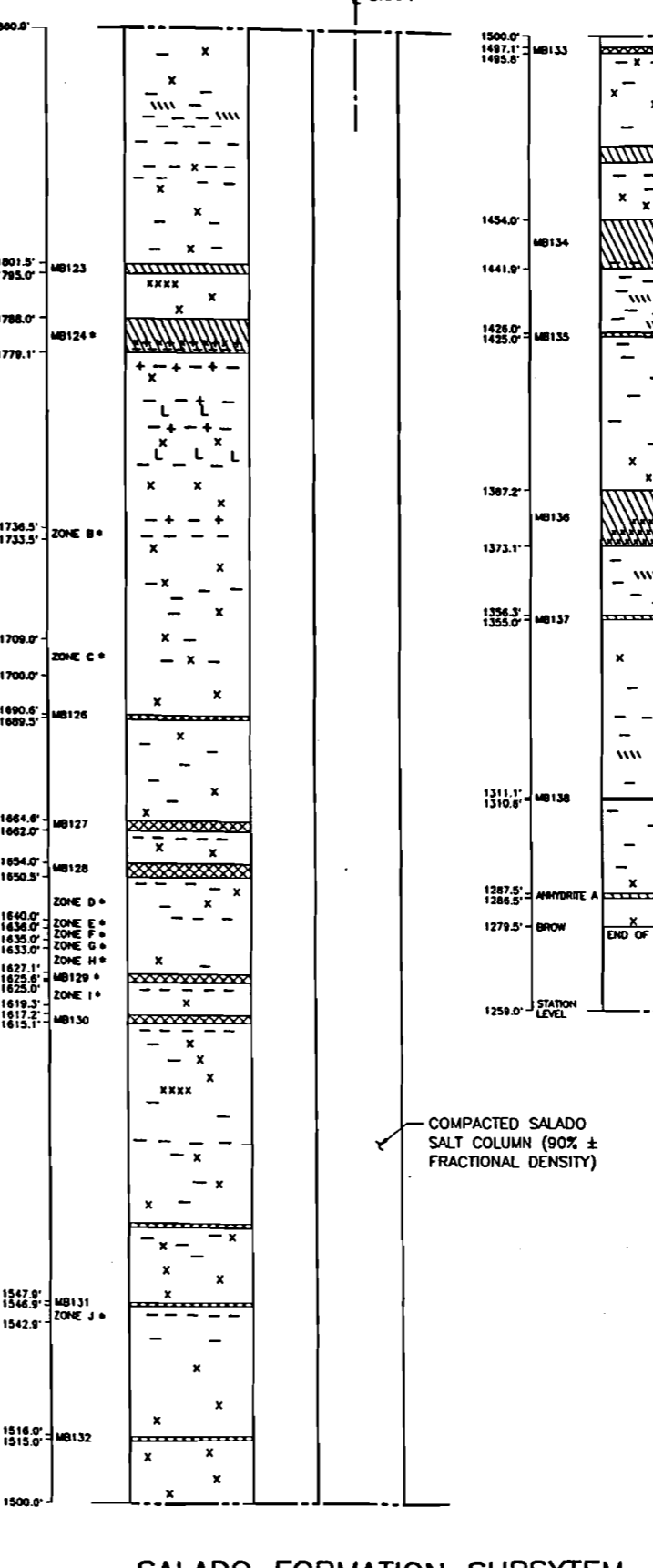
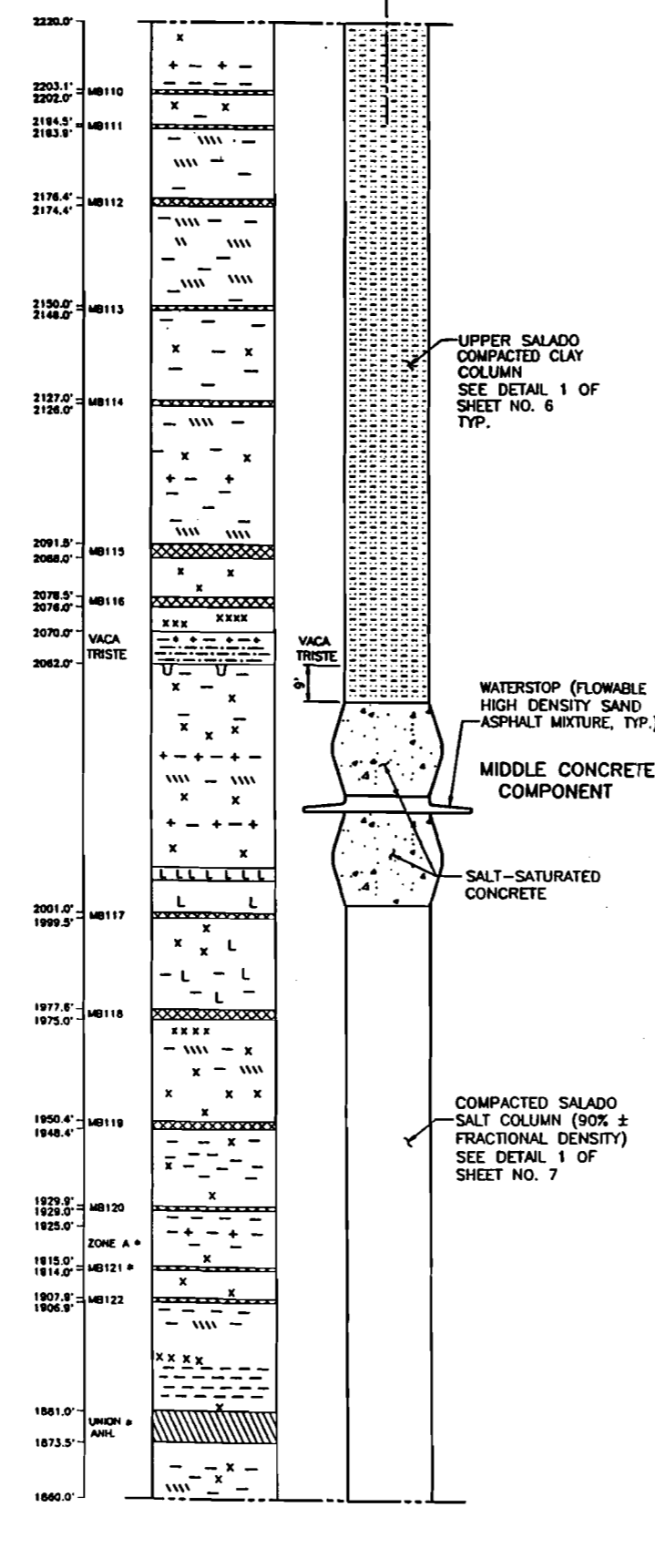
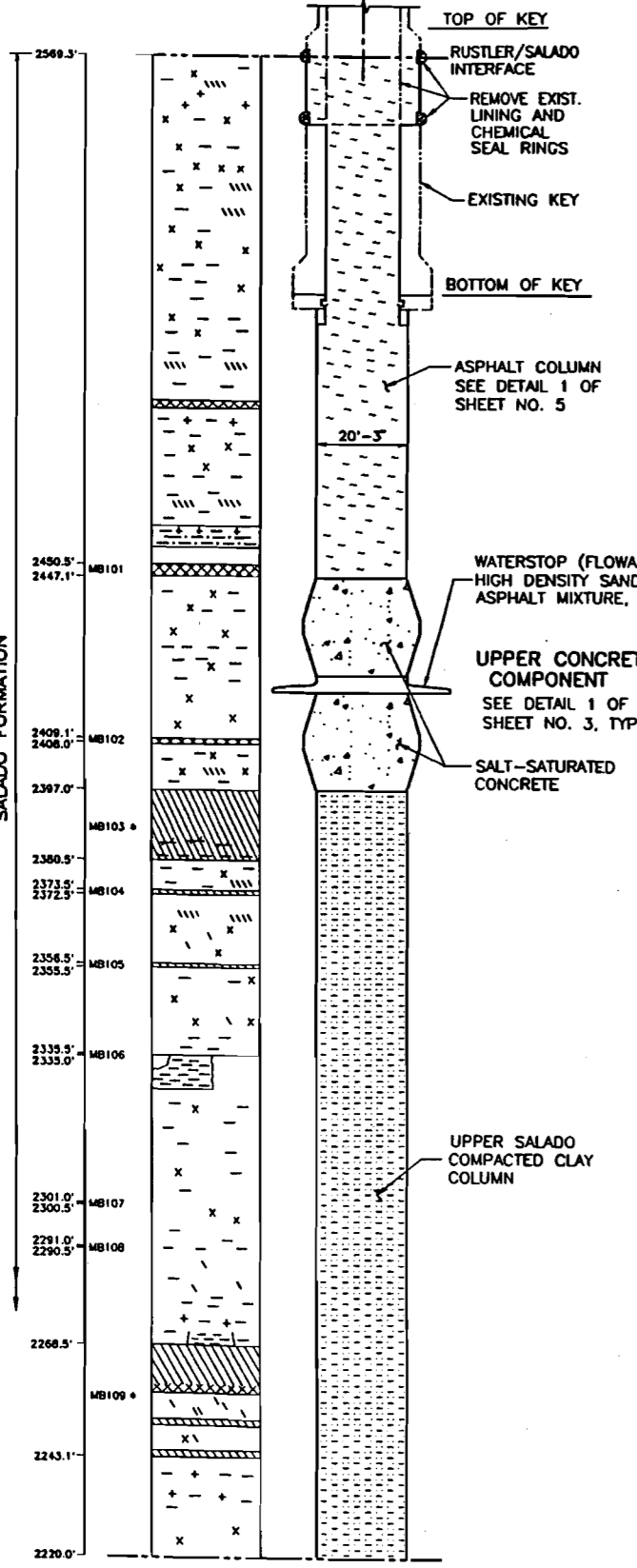

Figure B-5.



STRATIGRAPHY
(SEE NOTE 1 OF SHEET NO. 1)



SALADO FORMATION SUBSYSTEM

REV.	DATE	DESCRIPTION	BY	CK.	APP.
SANDIA NATIONAL LABORATORIES					
WIPP A/E SUPPORT					
WIPP SHAFT SEALING SYSTEM SALADO FORMATION			CONTRACT NO: AG-4909		
AIR INTAKE SHAFT STRATIGRAPHY AND SEALING SUBSYSTEM PROFILE			NAME	DATE	
			BY		
			CK.		
			APP.		
			APP.		
PARSONS BRINCKERHOFF ENERGY SERVICES, INC			SCALE: SIZE	SNL DWG. NO.	SHEET NO.
			B	33-SNL-005	2 OF 10

Figure B-6.

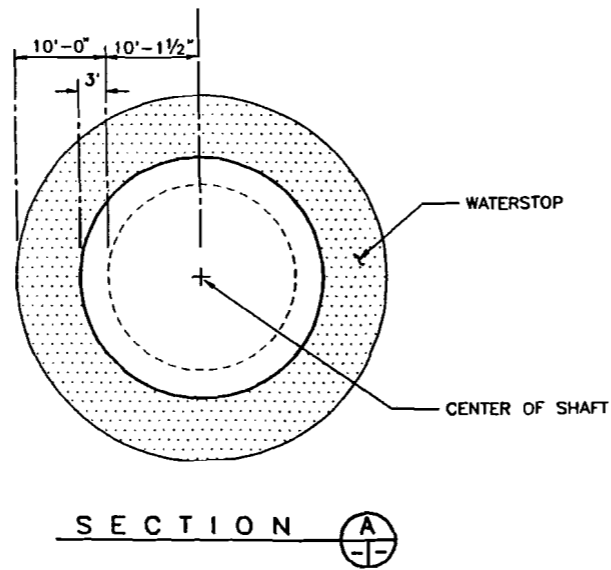
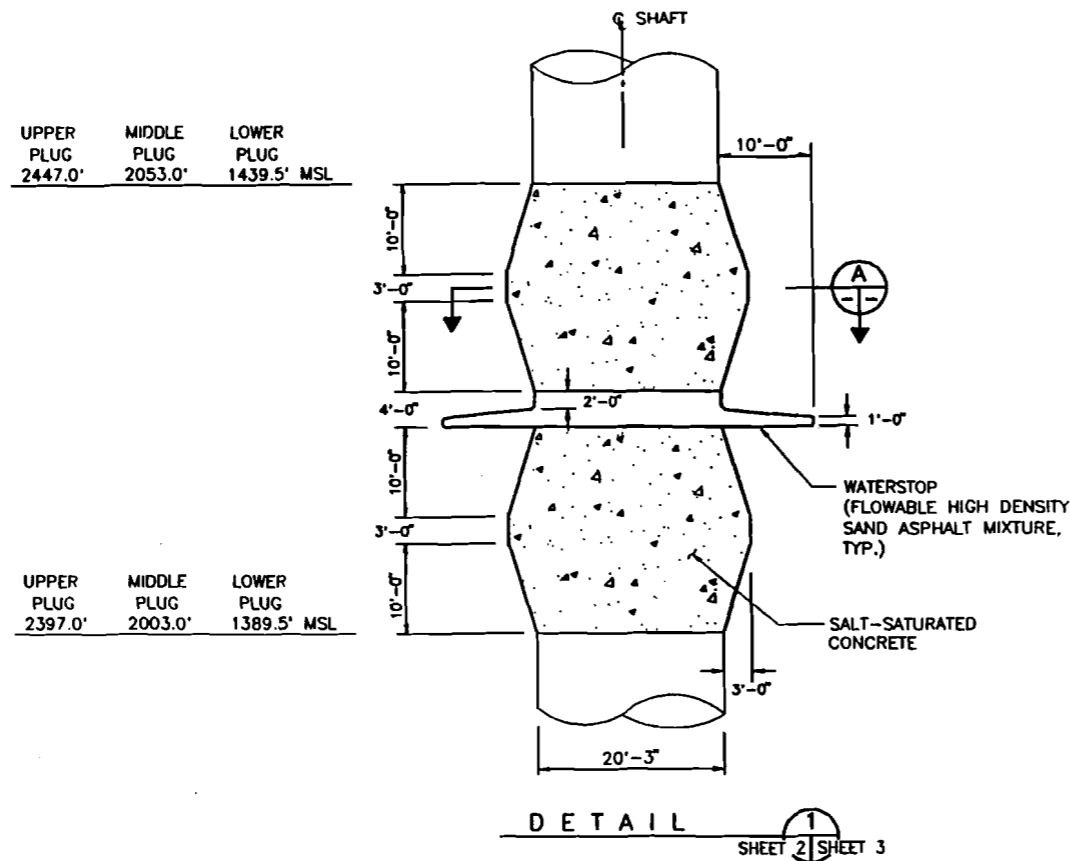

TYPICAL SALADO MASS CONCRETE PLUG
WITH WATERSTOP (3 LOCATIONS)

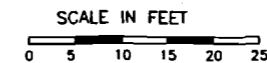

REV.	DATE	DESCRIPTION	BY	CK.	APP.
SANDIA NATIONAL LABORATORIES WIPP A/E SUPPORT WIPP SHAFT SEALING SYSTEM AIR INTAKE SHAFT CONCRETE COMPONENT IN SALADO FORMATION					
CONTRACT NO: AG-4909		NAME			
DATE		DATE			
BY: <i>W. D. ...</i>		DATE: <i>1/25/88</i>			
CK: <i>...</i>		DATE: <i>...</i>			
APP: <i>...</i>		DATE: <i>...</i>			
APP: <i>...</i>		DATE: <i>...</i>			
PARSONS BRINCKERHOFF ENERGY SERVICES, INC.	SCALE: B	SIZE: B	SNL DWG. NO. 33-SNL-005	SHEET NO. 3 OF 10	

Figure B-7.

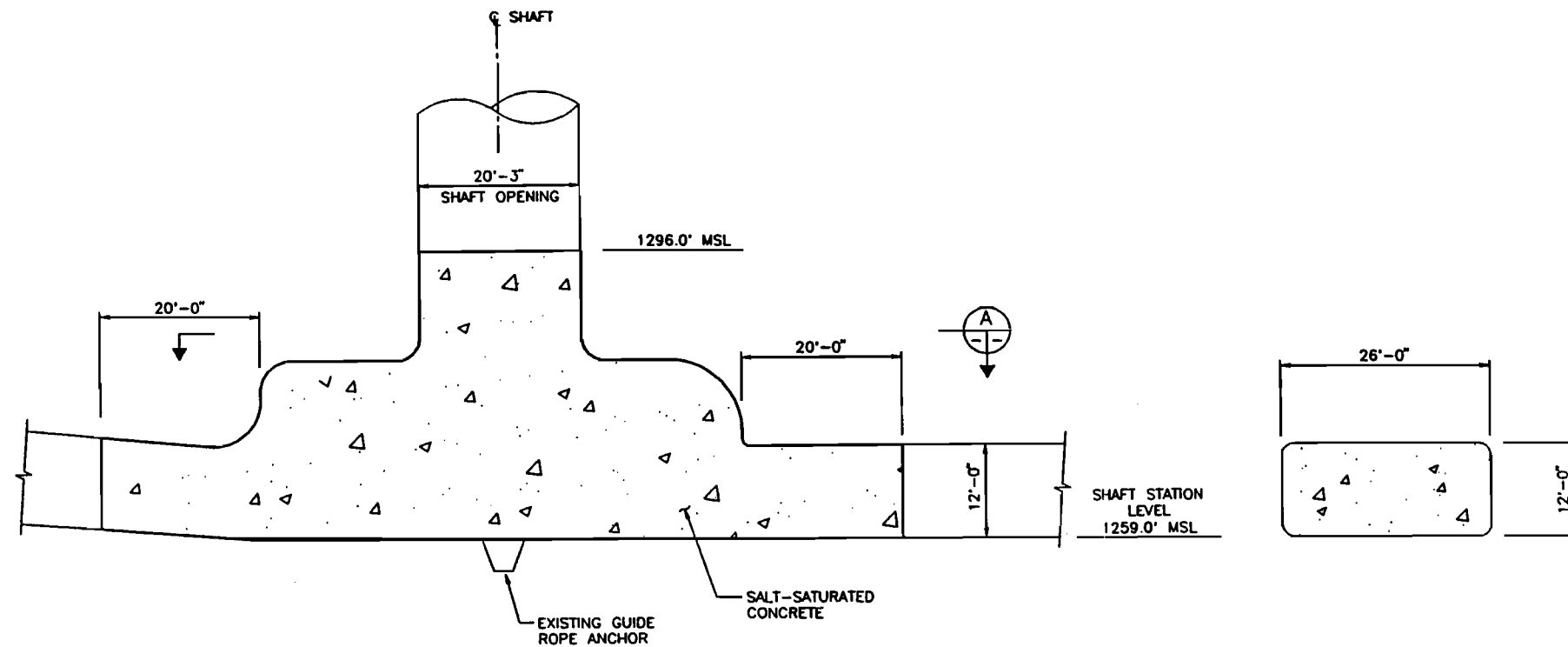

DETAIL 1
SHEET 2 | SHEET 4

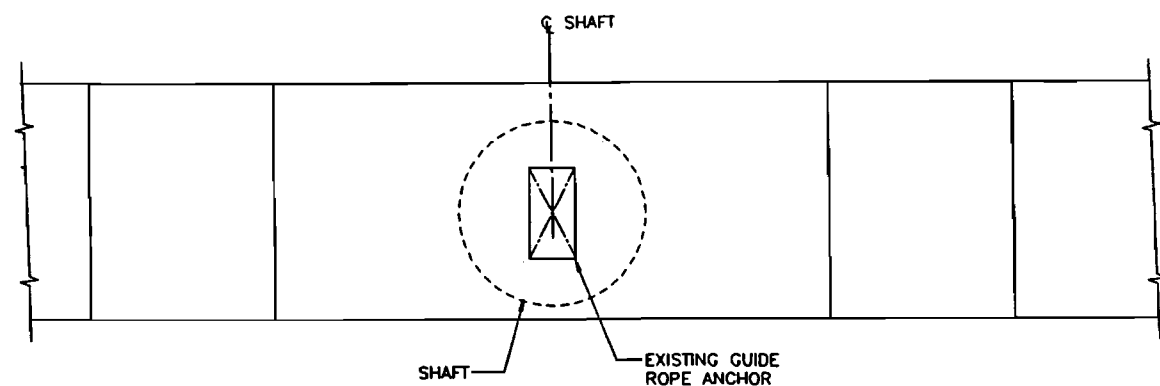

SECTION A

SHAFT STATION MONOLITH

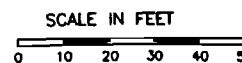

REV.	DATE	DESCRIPTION	BY	CK.	APP.
SANDIA NATIONAL LABORATORIES					
WIPP A/E SUPPORT					CONTRACT NO: AG-4908
WIPP SHAFT SEALING SYSTEM					
AIR INTAKE SHAFT SHAFT STATION MONOLITH					
		NAME	DATE		
		BY	11/23/95		
		CK.	12/1/95		
		APP.	11/27/95		
		APP.	12/1/95		
PARSONS BRINCKERHOFF ENERGY SERVICES, INC	SCALE:	SIZE B	SNL DWG. NO. 33-SNL-005	SHEET NO. 4 OF 10	

Figure B-8.

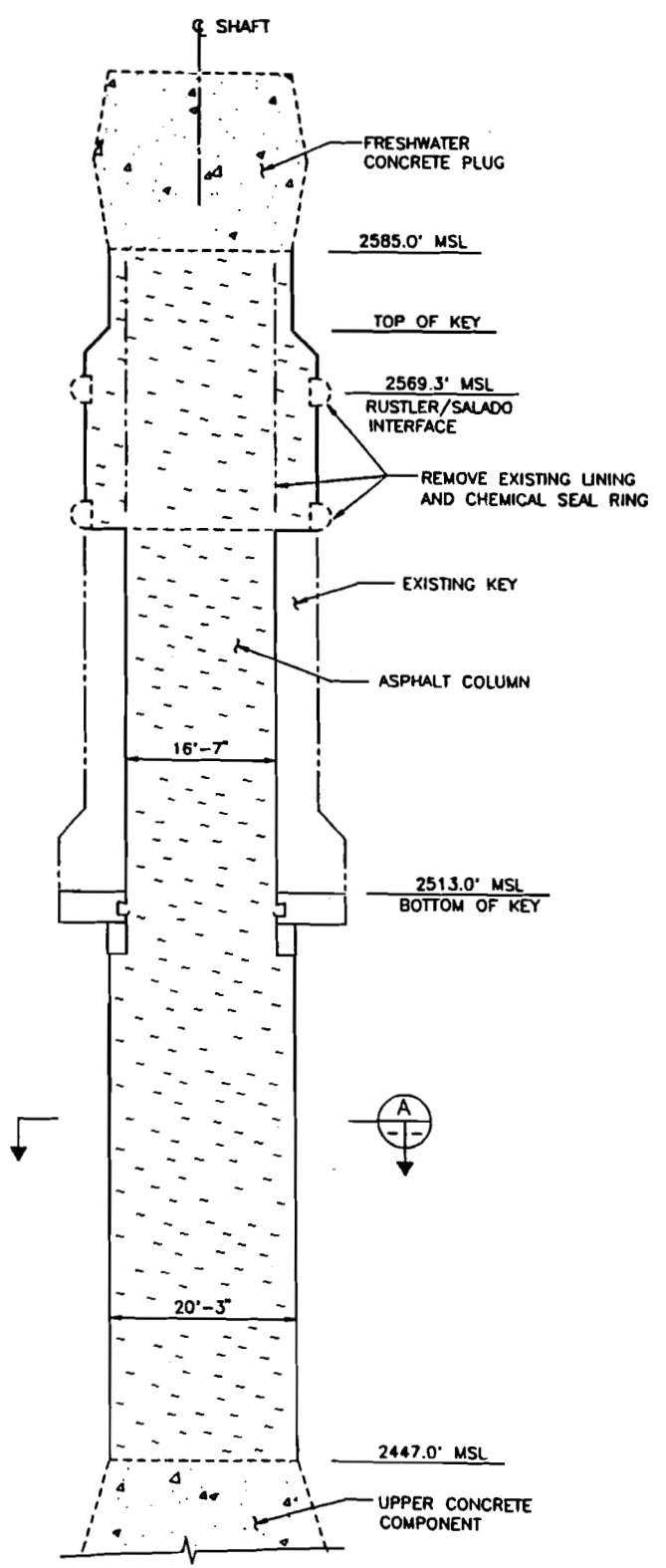

DETAIL
 SHEET 1 SHEET 5
 SHEET 2

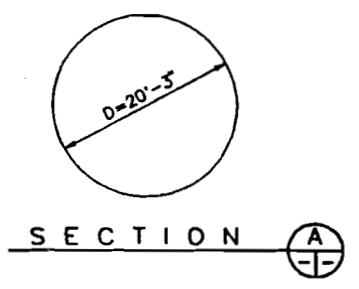

ASPHALT COLUMN
(2447' TO 2585' MSL)

SCALE IN FEET
 0 10 20 30 40 50

REV.	DATE	DESCRIPTION	BY	CK.	APP.
SANDIA NATIONAL LABORATORIES WIPP A/E SUPPORT WIPP SHAFT SEALING SYSTEM AIR INTAKE SHAFT ASPHALT COLUMN (2447' MSL TO 2585' MSL)					
PARSONS BRINCKERHOFF ENERGY SERVICES, INC.		SCALE: SIZE B	SNL DWG. NO. 33-SNL-005	SHEET NO. 3 OF 10	CONTRACT NO: AC-4908

Figure B-9.

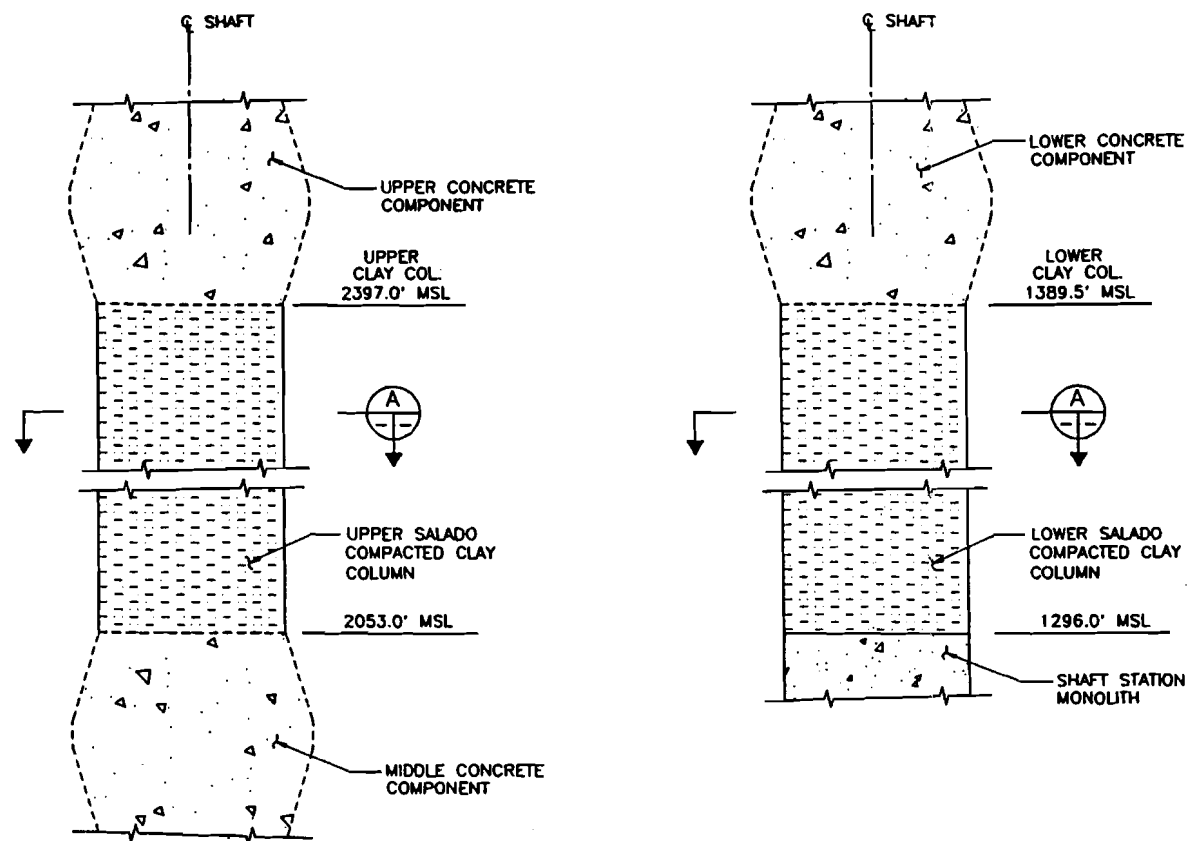

DETAIL 1
SHEET 2 | SHEET 6

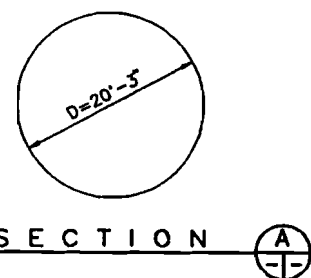

SALADO CLAY COLUMNS
(2 LOCATIONS)

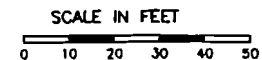

REV.	DATE	DESCRIPTION	BY	CK.	APP.
SANDIA NATIONAL LABORATORIES					
WIPP A/E SUPPORT					CONTRACT NO: AG-4909
WIPP SHAFT SEALING SYSTEM					
NAME		DATE			
BY: <i>W. Lee</i>		7/25/05			
CK: <i>W. Lee</i>		7/25/05			
APP: <i>W. Lee</i>		7/25/05			
APP: <i>W. Lee</i>		7/25/05			
APP: <i>W. Lee</i>		7/25/05			
PARSONS BRINCKERHOFF ENERGY SERVICES, INC.		SCALE: B	SIZE: B	SNL DWG. NO. 33-SNL-005	SHEET NO. 6 OF 10

Figure B-10.

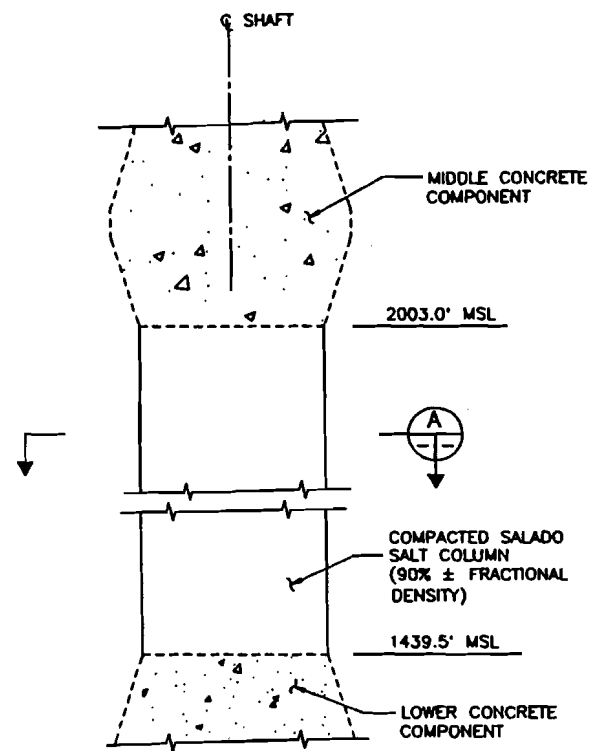

DETAIL 1
SHEET 2 | SHEET 7

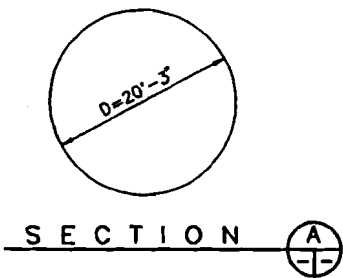

SALADO SALT COLUMN

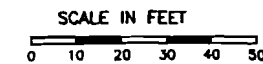

REV.	DATE	DESCRIPTION	BY	CHK.	APP.
SANDIA NATIONAL LABORATORIES					
WIPP A/E SUPPORT				CONTRACT NO: AG-4909	
WIPP SHAFT SEALING SYSTEM					
NAME		DATE			
BY	<i>W. J. ...</i>	9/25/93			
CK.	<i>...</i>	10/15/93			
APP.	<i>...</i>	11/15/93			
APP.	<i>...</i>	11/15/93			
PARSONS BRINCKERHOFF ENERGY SERVICES, INC		SCALE:	SIZE: B	SNL DWG. NO. 33-SNL-005	SHEET NO. 7 OF 10

Figure B-11.

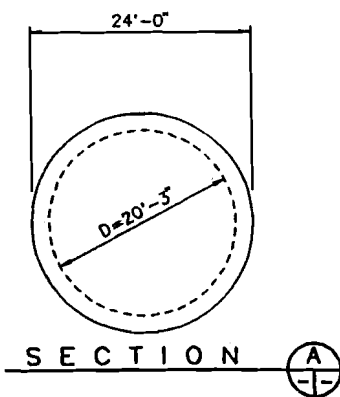
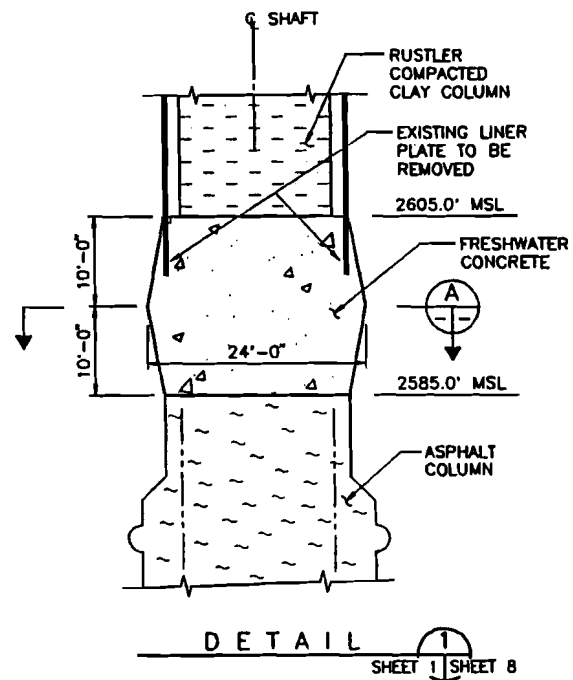

FRESHWATER CONCRETE PLUG



REV.	DATE	DESCRIPTION	BY	CK.	APP.
SANDIA NATIONAL LABORATORIES WIPP A/E SUPPORT WIPP SHAFT SEALING SYSTEM AIR INTAKE SHAFT FRESHWATER CONCRETE PLUG					
			CONTRACT NO: AG-4908		
BY		NAME	DATE		
CK.		NAME	DATE		
APP.		NAME	DATE		
APP.		NAME	DATE		
PARSONS BRINCKERHOFF ENERGY SERVICES, INC	SCALE: B	SIZE: B	SNL DWG. NO. 33-SNL-005	SHEET NO. 8 OF 10	

Figure B-12.

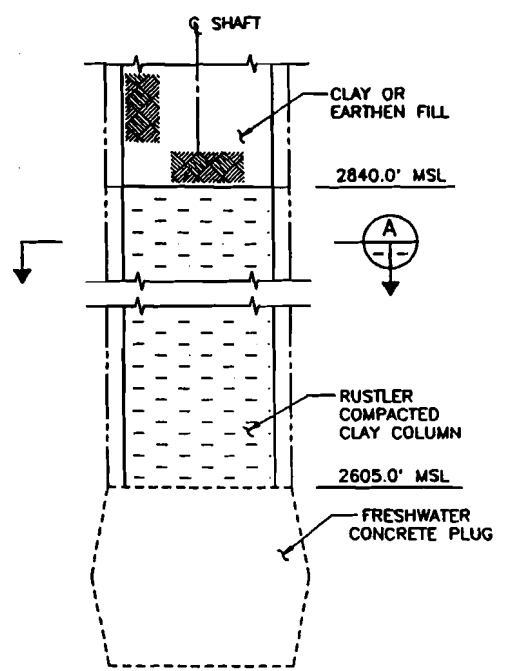

DETAIL 1
SHEET 1 | SHEET 9

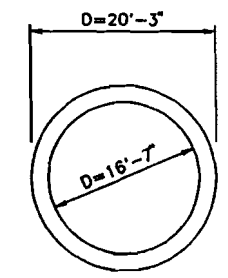

SECTION A

RUSTLER CLAY COLUMN

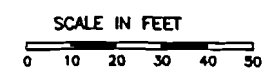

REV.	DATE	DESCRIPTION	BY	CK.	APP.
SANDIA NATIONAL LABORATORIES					
WIPP A/E SUPPORT				CONTRACT NO: AG-4909	
WIPP SHAFT SEALING SYSTEM					
BY	DATE				
CK.	DATE				
APP.	DATE				
APP.	DATE				
AIR INTAKE SHAFT RUSTLER CLAY COLUMN					
PARSONS BRINCKERHOFF ENERGY SERVICES, INC	SCALE:	SIZE	SNL DWG. NO.	SHEET NO.	
		8	33-SNL-005	9 OF 10	

Figure B-13.

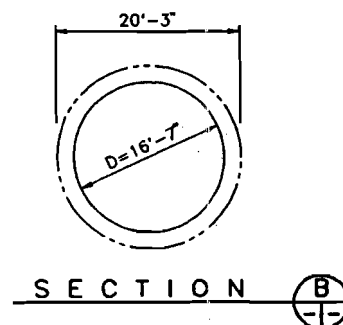
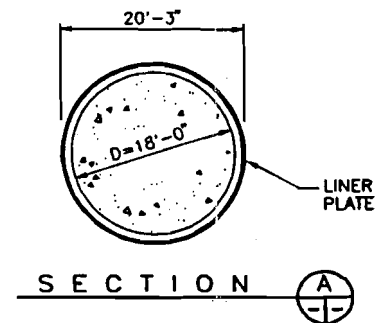
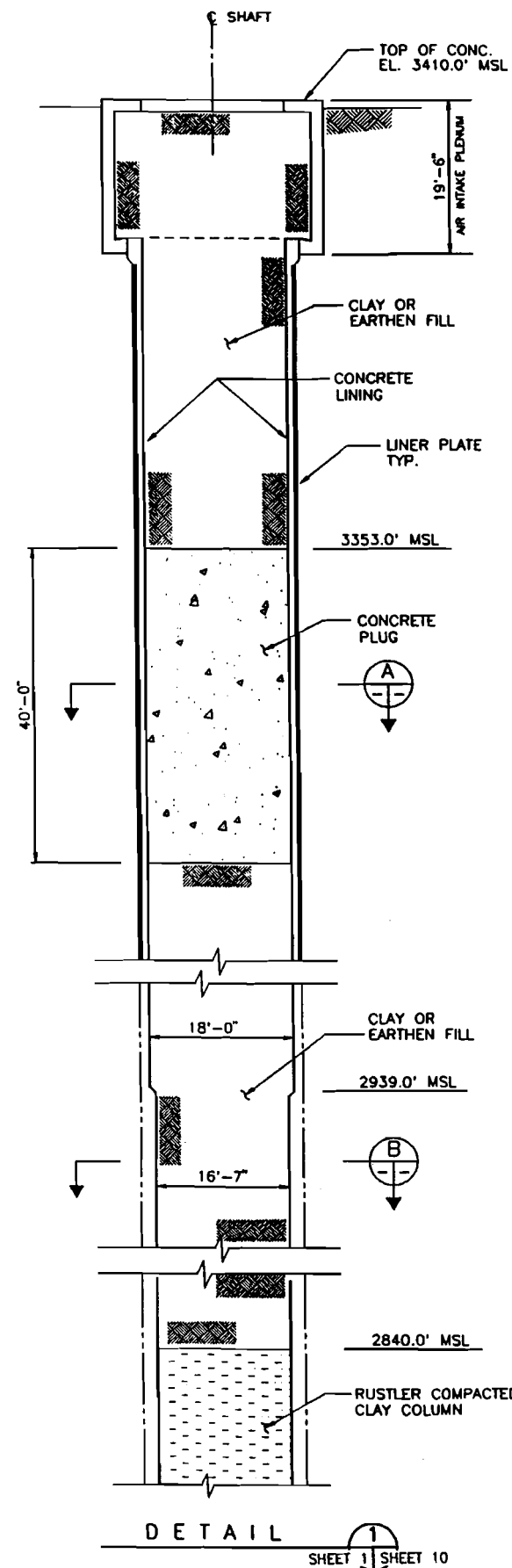

**DEWEY LAKE CLAY/EARTHEN FILL
COLUMN AND CAP**

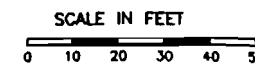

DETAIL
SHEET 1 SHEET 10

REV.	DATE	DESCRIPTION	BY	CK.	APP.
SANDIA NATIONAL LABORATORIES					
WIPP A/E SUPPORT					
				CONTRACT NO. AC-4909	
WIPP SHAFT SEALING SYSTEM					
AIR INTAKE SHAFT					
DEWEY LAKE CLAY/EARTHEN					
FILL COLUMN AND CAP					
PARSONS BRINCKERHOFF ENERGY SERVICES, INC.		SCALE:	SIZE 8	SNL DWG. NO. 33-SNL-005	SHEET NO. 10 OF 10

Figure B-14.

WIPP Sealing System Design Report

**Appendix C:
A Modeling Study on Shaft Seal Permeability**

WIPP Sealing System Design Report

Appendix C: A Modeling Study on Shaft Seal Permeability

This appendix summarizes a modeling study conducted to evaluate the sensitivity of repository performance to permeability of the shaft seal system. The simulations as discussed here show that, for a composite shaft of 100 m length:

- to limit brine flow, a seal permeability of about $1 \times 10^{-16} \text{ m}^2$ is sufficient and
- reduction of gas flow requires a seal permeability on the order of $1 \times 10^{-18} \text{ m}^2$ or tighter.

C.1 Conceptual Models

A conceptual model of the repository comprises a tool used to evaluate the repository, the enclosed waste, and the surrounding geologic media. A conceptual model is the aggregate of processes, properties, and geometries considered within an analysis. It encompasses process models, which are verbal or mathematical descriptions of the conceptual model, a numerical model consisting of the computer code used to conduct simulations of the process model, and parameters. Parameters required for this conceptual model consist of data derived from field and laboratory experiments, and numerical quantities necessary for computer code implementation. The following sections identify the computer codes used for the simulations and briefly discuss the process models and parameter derivations for this study.

C.2 Computer Codes

All simulations were performed using BRAGFLO, a two-phase flow simulator developed by SNL. It has been designed to accommodate conceptual model changes and to be robust and numerically stable over a wide range of flow conditions. BRAGFLO is used by the WIPP Performance Assessment Group in the conduct of assessments for the program.

Fluid flow processes at the WIPP horizon are physically coupled to the creep closure of the surrounding salt. Implementation of a fully coupled system results in significant technical difficulties that cannot be practically overcome at the present time. A simplified approach has been used in this modeling study. The principal effects of disposal room closure on two-phase flow are captured through the use of a separate calculation for the effective porosity of a waste-filled room as a function of time and total moles of gas generated. The computer code SANCHO was used for the calculation. Results of the calculation are implemented in BRAGFLO through the use of a "look-up" table of porosity values.

C.3 Parameter Values

The calculations presented in this appendix were conducted to provide a baseline for a subsequent set of simulations used in a Systems Prioritization study. Parameter values and ranges were derived from the Position Papers and elicitation interviews with WIPP Principal Investigators. The parameter ranges used for the simulations incorporated both conservative and optimistic estimates of parameter values. Within the context of a sensitivity study, this parameter variation provides an excellent opportunity to investigate the system response to a wide range of inputs.

WIPP Sealing System Design Report

The physical properties for the geologic media, as well as those parameters governing gas generation, have significant quantitative variation. This variation is addressed through the use of a probabilistic, Latin Hypercube Sampling (LHS) method. The LHS approach generates a set of input vectors from the distribution of input parameters, which cover the space of parameter variation.

The sensitivity study presented here used a total of 75 input vectors, with seal permeabilities ranging from 10^{-13} to 10^{-19} m^2 . The equivalent shaft region is subdivided into upper and lower regions. Each region consists of a Seal element and a Shaft element. These simulations assumed that only the Lower Seal element (length of 100 m) functioned as a fluid flow barrier. The remainder of the shaft regions were assumed to consist of a permeable fill (intrinsic permeability of 10^{-12} m^2) material.

C.4 Simulation Results

The performance measures used to assess the sensitivity of the system to material permeabilities are: (1) brine flow up or down the shaft and (2) gas flow up the shaft. These measures are consistent with design guidance that the shafts limit flow to acceptable levels. A scatter plot of the cumulative brine flow through the shaft is illustrated in Figure C-1. Results for all 75 input vectors are depicted on this plot. The cumulative brine flow was calculated at the top of the lower seal element. These results show that brine flows through the seal are not significantly reduced until the Lower Shaft permeability is reduced to 10^{-16} m^2 . Zero brine flow is achieved with a permeability of 10^{-17} m^2 . The cumulative gas flow for all input vectors is shown in Figure C-2. These results show that a reduction of gas flow up the shaft does not begin until the lower shaft permeability is reduced to 10^{-18} m^2 .

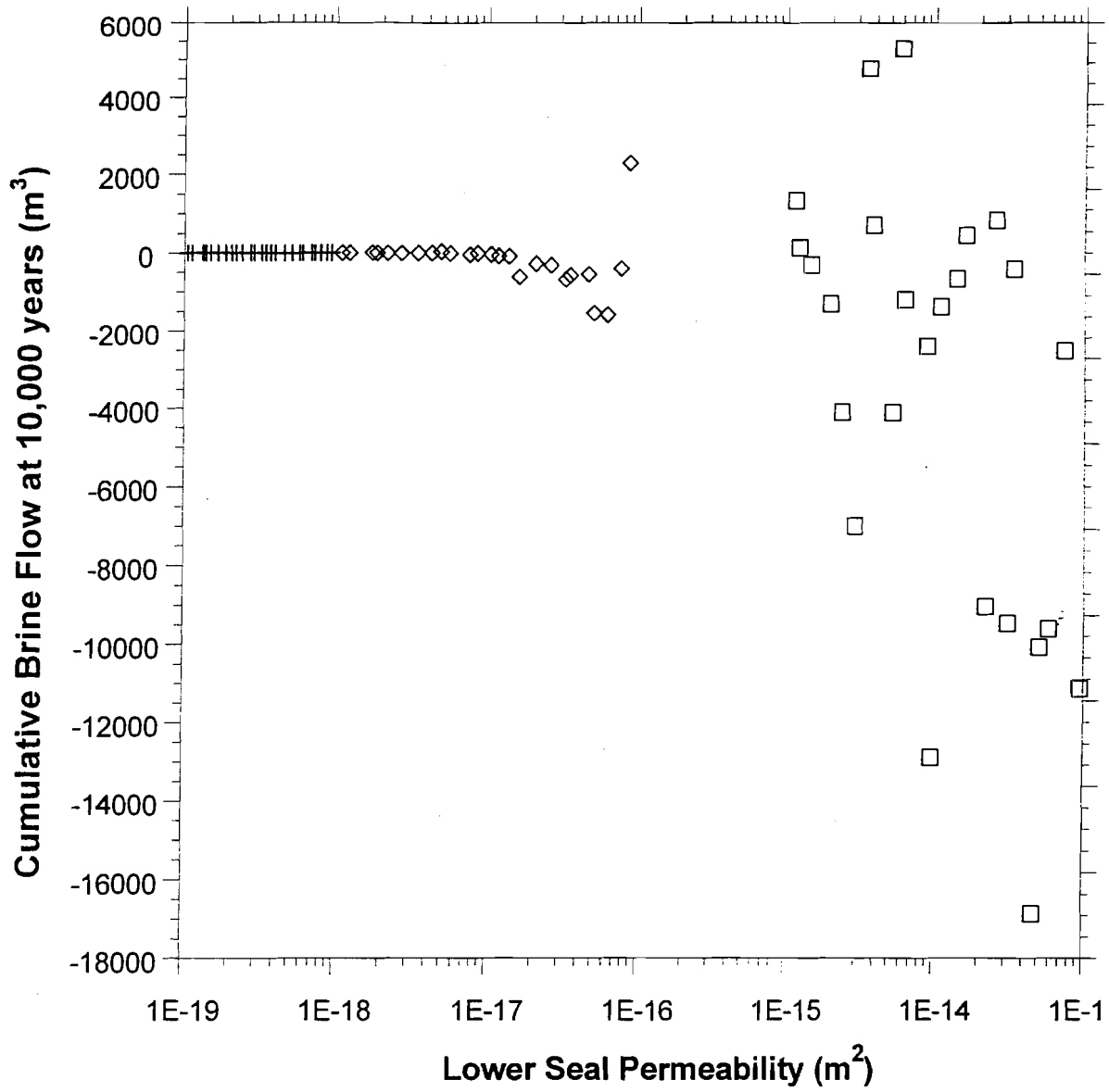

Figure C-1. Predicted cumulative brine flow through lower seal.

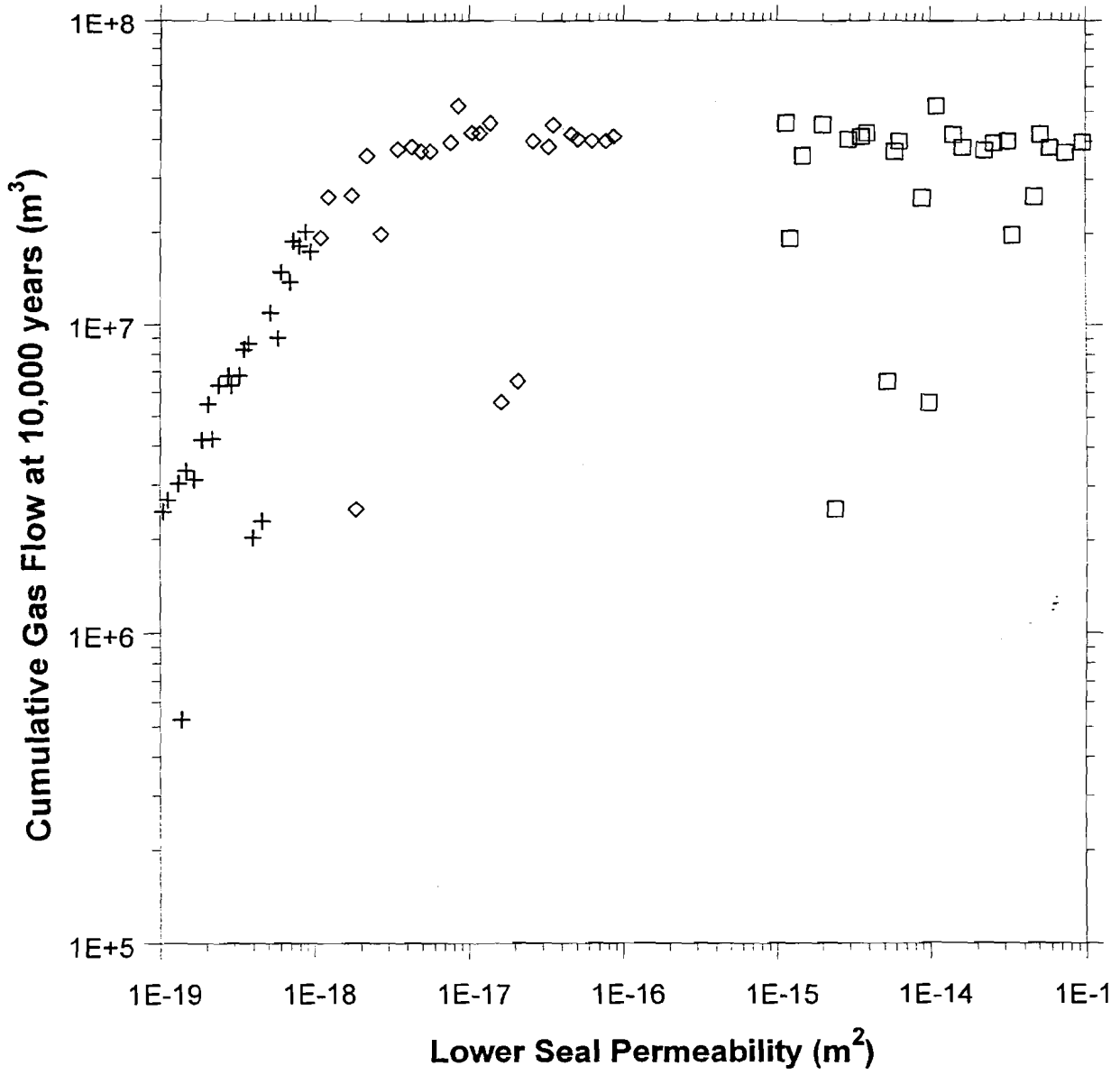

Figure C-2. Predicted cumulative gas flow through lower seal.

**Appendix D:
Comparative Analysis of the Seal System Design**

WIPP Sealing System Design Report

APPENDIX D: Comparative Analysis of the Seal System Design

D.1 Introduction

The calculations presented in this appendix are scoping in nature. Verification of the performance of the seal system is currently being performed through detailed multi-phase flow simulations which model the dominant flow processes expected in the seal system. The comparison presented in this appendix provides evidence that the seal system described in this report meets the design guidance described in Section 2.

This appendix is organized into four sections in addition to the introduction. Section D.2 presents the quantitative design guidance for the WIPP shaft seal system as provided by modeling studies of the seal system. Section D.3 provides the specifics behind the analysis approach applied, as well as a discussion of analysis assumptions and inputs. Section D.4 presents the comparison of the design relative to the design guidance.

D.2 Design Guidance

The general requirement of limiting fluid flow through the seal system can be divided into specific functions based on the physical characteristics of the WIPP shaft sealing system and the surrounding media. The Rustler Formation is considered the primary source of brine to the shaft sealing system. The Salado Formation, although saturated, has a very low permeability and thus a low potential as a significant brine source. As currently conceptualized, the repository will produce significant quantities of gas capable of inducing significant pressure build-up at the base of the shaft over time. The WIPP shaft sealing system is designed to restrict the flow of gas at pressures less than lithostatic.

The primary source of significant groundwater flow to the shaft sealing system is the Rustler Formation. The upper shaft seal system must limit Rustler brine migrating down the shaft. The reasons for limiting brine migration in the seal system from the Rustler are: (1) to block water from reaching the repository; and (2) to limit the development of significant pore pressures in the compacted salt column.

The lower shaft seal system must also limit fluid flow. The lower seal system must limit gas or brine released from the repository horizon from migrating up the seal system. The reasons for limiting gas and brine from migrating up the shaft from the repository are: (1) to prevent the release of radionuclides or hazardous constituents; (2) to prevent significant pore pressures from building up in the compacted salt column during the 100 years following closure; and (3) to

WIPP Sealing System Design Report

prevent possible seal degradation from active circulation of fluids. The release of gas from the repository horizon through the shaft may not directly influence compliance. However, because gas has the potential to impede consolidation of the compacted salt column, the lower seal will need to prevent significant gas pressures from building in the compacted salt column for a period of 100 years.

Sensitivity modeling has recently been performed with the objective of determining the sensitivity of brine and gas flow within the WIPP shaft sealing system to shaft seal permeability. This sensitivity study has provided preliminary design guidance for the shaft sealing system. The sensitivity study modeled the four existing WIPP shafts as one equivalent shaft with an area equal to that of the four shafts. Results from the sensitivity study determined that, for a shaft seal to limit migration of brine, the seal must have an intrinsic permeability of less than or equal to $1 \times 10^{-16} \text{ m}^2$ over an effective seal length of 100 m or greater. The simulation results also showed that to significantly impede gas migration from the repository, the lower seal must have an intrinsic permeability less than or equal to 10^{-18} m^2 over an effective seal length of 100 m or greater.

In this appendix, a comparative analysis will be performed based on the quantitative design guidance provided by the sensitivity analyses. This analysis does not represent a hydraulic analysis and seal system flow rates are not calculated. The analysis will compare each component of the seal system to the quantitative design guidance described above. This analysis will provide a method to determine if the sealing system design provides adequate sealing properties as compared to the design guidance.

D.3 Analysis Approach

The analysis compares flow potential as defined by hydraulic conductance for both the design cross-sectional seal and the expected disturbed rock zone (DRZ) and compares this to the quantitative design guidance. Seal material and rock permeabilities are also required as input. This section will define the analytical approach used, the analysis inputs, and the assumptions.

D.3.1 Analysis Methodology

Single-phase fluid flow through a porous medium is governed by Darcy's Law. Darcy's Law for steady-state flow can be expressed as:

$$Q = -KA \frac{dh}{dl} \quad (\text{D-1})$$

where Q is the volumetric flow rate (m^3/s), K is the hydraulic conductivity of the porous medium (m/s), dh is the difference in hydraulic head across the porous medium (m), dl is the length across which dh is measured (m), and A is the cross-sectional area normal to the flow direction (m^2). The hydraulic conductivity is a property of the porous medium and of the fluid saturating

WIPP Sealing System Design Report

the pore space. Hydraulic conductivity is equal to:

$$K = \frac{k \rho g}{\mu} \quad (D-2)$$

where k is the intrinsic permeability of the porous medium (m^2), ρ is the fluid density (kg/m^3), g is the acceleration of gravity (m/s^2), and μ is the fluid viscosity ($Pa \cdot s$). Using WIPP reference values for a brine, hydraulic conductivity is equal to intrinsic permeability multiplied by a factor equal to 6.69×10^6 .

The design guidance for seal permeability and seal length resulting from model sensitivity calculations cannot be directly compared to the seal design for the Air Intake Shaft (AIS). The model combines all four WIPP shafts as one equivalent shaft with an area of $100 m^2$. To compare sensitivity results to the seal design, one must consider permeabilities, lengths, and areas, which are different between the seal design and the model. The AIS has an area of approximately $30 m^2$, which is approximately 30% of the shaft area modeled in the simulations.

Therefore, a method of couching the results from modeling (design guidance) into a form which can be compared to a seal design with variable length, permeability, and area relative to the model seal guidance is required. The term which allows this is the hydraulic conductance. The hydraulic conductance is a measure of a system's ability to transmit water and is equivalent to thermal conductance in heat flow problems. The hydraulic conductance of a porous medium is derived from area, length, and hydraulic conductivity, and is the inverse of the hydraulic resistance. The hydraulic conductance, defined in terms of intrinsic permeability, can be expressed as:

$$C = \frac{kA}{L} \frac{\rho g}{\mu} = \frac{KA}{L} \quad (D-3)$$

where C is the hydraulic conductance (m^2/s), k is the intrinsic permeability (m^2), A is the area (m^2), L is the component length (m), ρ is the fluid density (kg/m^3), g is the acceleration of gravity (m/s^2), and μ is the fluid viscosity ($Pa \cdot s$).

By using equation D-3, the design guidance for the upper and lower seals can be expressed as hydraulic conductance and can be used for direct comparison with the seal design presented in this report. To limit brine flow in the shaft, modeling indicated that a seal length of 100 m, permeability of $1 \times 10^{-16} m^2$, and area of $100 m^2$ must exist in the shaft. Assuming a viscosity of $0.0018 Pa \cdot s$, a fluid density of $1230 kg/m^3$, and an acceleration of gravity constant of $9.792 m/s^2$, the brine seal guidance translates into a hydraulic conductance equal to $6.7 \times 10^{-10} m^2/s$. For limiting gas flow in the shaft, modeling indicated that a seal length of 100 m, permeability of $1 \times 10^{-18} m^2$, and area of $100 m^2$ must exist in the shaft. Assuming fluid properties representative of a WIPP brine (see above), the gas seal guidance translates into a hydraulic conductance equal to $6.7 \times 10^{-12} m^2/s$. Because the AIS contributes 30% of the area of

WIPP Sealing System Design Report

the equivalent shaft, these hydraulic conductances should be reduced to 30% for comparison to the AIS seal dimensions. This results in a brine seal guidance hydraulic conductance of 2.0×10^{-10} m^2/s and a gas seal guidance hydraulic conductance of 2.0×10^{-12} m^2/s . In the calculation of hydraulic conductance, brine properties are assumed for both brine and gas. This assumption is justified because the analysis is comparative and the physical properties of the permeating fluid are unimportant as long as they are the same as those used to calculate the design guidance hydraulic conductance. Calculations predicting performance of the shaft sealing system require rigorous application of multiphase properties and are beyond the scope of this appendix.

To determine if the seal design meets the design guidance provided by modeling results, the hydraulic conductance of the AIS seal design is computed and compared to the design guidance. The computation of seal hydraulic conductance is based on a component-by-component basis consistent with the seal design description found in Section 3 of this report.

The hydraulic analysis considers the cross-sectional area of the seal for flow plus the cross-sectional area of the DRZ normal to the axis of the shaft. The hydraulic conductance of the cross-sectional seal and the DRZ are added to get the total hydraulic conductance of a specific component of the seal design, as illustrated in Figure D-1. For parallel flow, the appropriate law of composition is simply to add the hydraulic conductances of the seal and the DRZ. The zone with the largest hydraulic conductance dominates the total hydraulic conductance. The total seal system (seal plus DRZ) hydraulic conductance is then compared to the guidance hydraulic conductance.

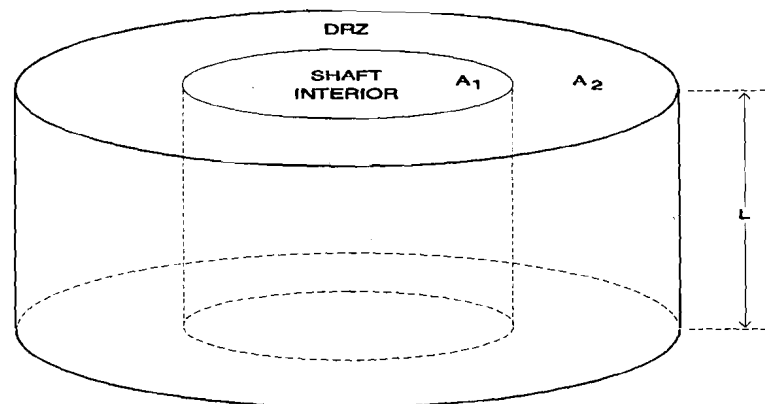

Hydraulic Conductance of Shaft

$$\frac{kA_1}{L} \quad \frac{p\theta}{\mu}$$

Hydraulic Conductance of DRZ

$$\frac{kA_2}{L} \quad \frac{p\theta}{\mu}$$

Combined Hydraulic Conductance

$$\frac{kA_1+kA_2}{L} \quad \left(\frac{p\theta}{\mu} \right)$$

Figure D-1. Schematic of Seal System and Definition of Hydraulic Conductance

WIPP Sealing System Design Report

The determination of the DRZ hydraulic conductance is based on the assumption that the permeability is greatest in the DRZ near the excavation face and decreases log-linearly as one approaches the outer extent of the DRZ. Figure D-2 shows a schematic of a shaft with a DRZ of inner radius r_i and outer radius r_o . It is assumed that the permeability k_i at r_i is several orders of magnitude higher than the intact undisturbed permeability defined at r_o . The functional relationship between the variation in permeability as a function of radius is unknown. The calculations in this appendix assume that the change in permeability within the DRZ can be described by a linear change in log permeability. Therefore, for a given r_i , k_i , r_o , and k_o , an effective DRZ permeability is calculated which accounts for both the decrease in DRZ permeability and the increase in flow area as a function of radius away from the excavation. The equation for the effective DRZ permeability is

$$k_{DRZ} = \frac{2}{r_o + r_i} \left[\left(\frac{r_o (\ln(k_o) - \ln(k_i)) - \Delta r}{(\ln(k_o) - \ln(k_i))^2} \right) k_o - \left(\frac{r_i (\ln(k_o) - \ln(k_i)) - \Delta r}{(\ln(k_o) - \ln(k_i))^2} \right) k_i \right]$$

where Δr is equal to the outer DRZ radius minus the inner DRZ radius.

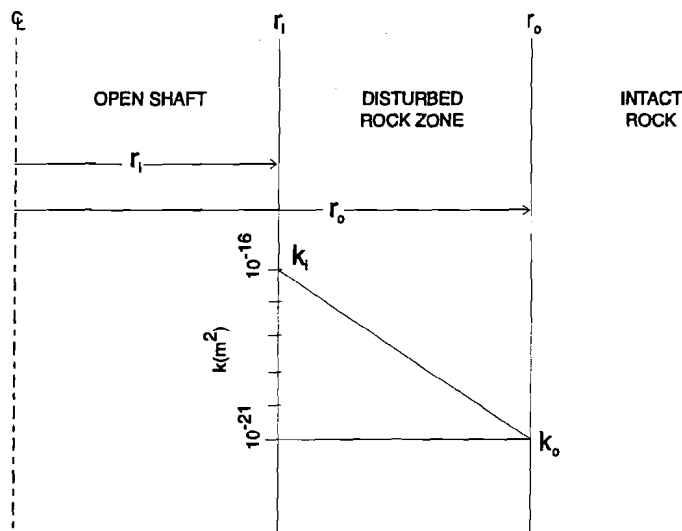

k_i REPRESENTS MAXIMUM DILATION
 k_o REPRESENTS INTACT CONDITIONS
 r_i EXCAVATION FACE, INNER RADIUS OF DRZ
 r_o OUTER RADIUS OF DRZ

Figure D-2. Log-linear model for the calculation of an effective permeability of the DRZ.

D.3.2 Analysis Assumptions

There are several assumptions inherent in the calculation of hydraulic conductance. These assumptions are listed below.

- Reference fluid properties representative of WIPP brine are used in calculations of hydraulic conductance. Because the analysis is a comparative study, these properties are unimportant to the analysis.
- Flow through the seal system is limited to the cross-sectional seal and the DRZ. Interface flow is not considered; therefore the hydraulic conductance is calculated for the seal plus the DRZ only.
- The comparative analysis is performed for the AIS. The dimensions of the seal components and the DRZ components are representative of the AIS.
- Properties of the seal materials are described in Section 4. Transient seal permeabilities are used for concrete and for the compacted salt column. The concrete components are not assigned a sealing function after 100 years. They are replaced by a silty sand with a permeability of $1 \times 10^{-14} \text{ m}^2$. The consolidated salt permeability varies as a function of relative density according to the Knowles-Hansen (Figure D-8) functional relationship;
- The Salado is modeled as argillaceous;
- Salt creep can be defined by the modified Munson-Dawson (M-D) creep material model (Munson et al., 1989). The salt DRZ can be described by the Multi-Deformation Coupled-Fracture (MDCF) material constitutive model which provides a continuum description of the response and the associated damage evolution of rock salt;
- Asphalt, for purposes of these calculations, is considered a porous medium. This is necessitated by the assumptions of the hydraulic evaluation. It is understood that asphalt is a separate phase from water or gas. The water permeability of asphalt liquid is effectively zero; therefore, this assumption is considered conservative;
- The seal system is evaluated at 0, 10, 50, and 100 years. In this analysis, hydraulic properties of the seal and DRZ are considered constant beyond 100 years.

D.3.3 Analysis Parameters

Several analysis inputs are required for the hydraulic conductance calculations. These include: (1) compacted salt column fractional density as a function of time; (2) DRZ radius as a function of time, depth, and sealing material; and (3) the intrinsic permeability of the seal materials and the Salado DRZ. These parameters are discussed below.

D.3.3.1 Reconsolidated Salt Fractional Density

The salt in the compacted salt column will continue to consolidate after emplacement in the shaft as a result of salt creep. RE/SPEC (1995) calculated the fractional density of a salt column in the Salado for various depths over a 1,000 year time period. The calculations were performed with a series of "pineapple slice" models at depths of 250 m, 350 m, 450 m, 550 m, and 650 m. These five depths were considered adequate to define the functional relationship between salt fractional density, depth, and time. The primary assumptions of the analysis are:

- The calculations are based upon finite deformation solutions;
- The initial fractional densities of the salt are 0.80, 0.85, 0.90, and 0.95;
- The stratigraphy of the Salado is not considered; instead the Salado is considered homogeneous as a clean or argillaceous halite;
- The shaft has a uniform diameter of 6.1 m;
- The initial stress state prior to excavation is lithostatic;
- The excavation occurs at -50 years and remains open for 50 years until time zero, when the salt seal material is emplaced instantaneously.

The crushed salt consolidation is governed by the constitutive model described by Callahan and DeVries (1991) and Callahan (1993). For the calculations presented in this appendix, the initial emplacement fractional density is 0.90. Using calculations presented in RE/SPEC (1995), the fractional density as a function of depth and time was determined for an initial fractional density of 0.90 through linear interpolation. Figure D-3 provides the fractional density relationship based on an initial emplacement density of 0.90 and the salt is argillaceous. These parameters are used to estimate the compacted salt column fractional density. Fractional density is then used to define the permeability of the salt seal (see Section D.3.3.3).

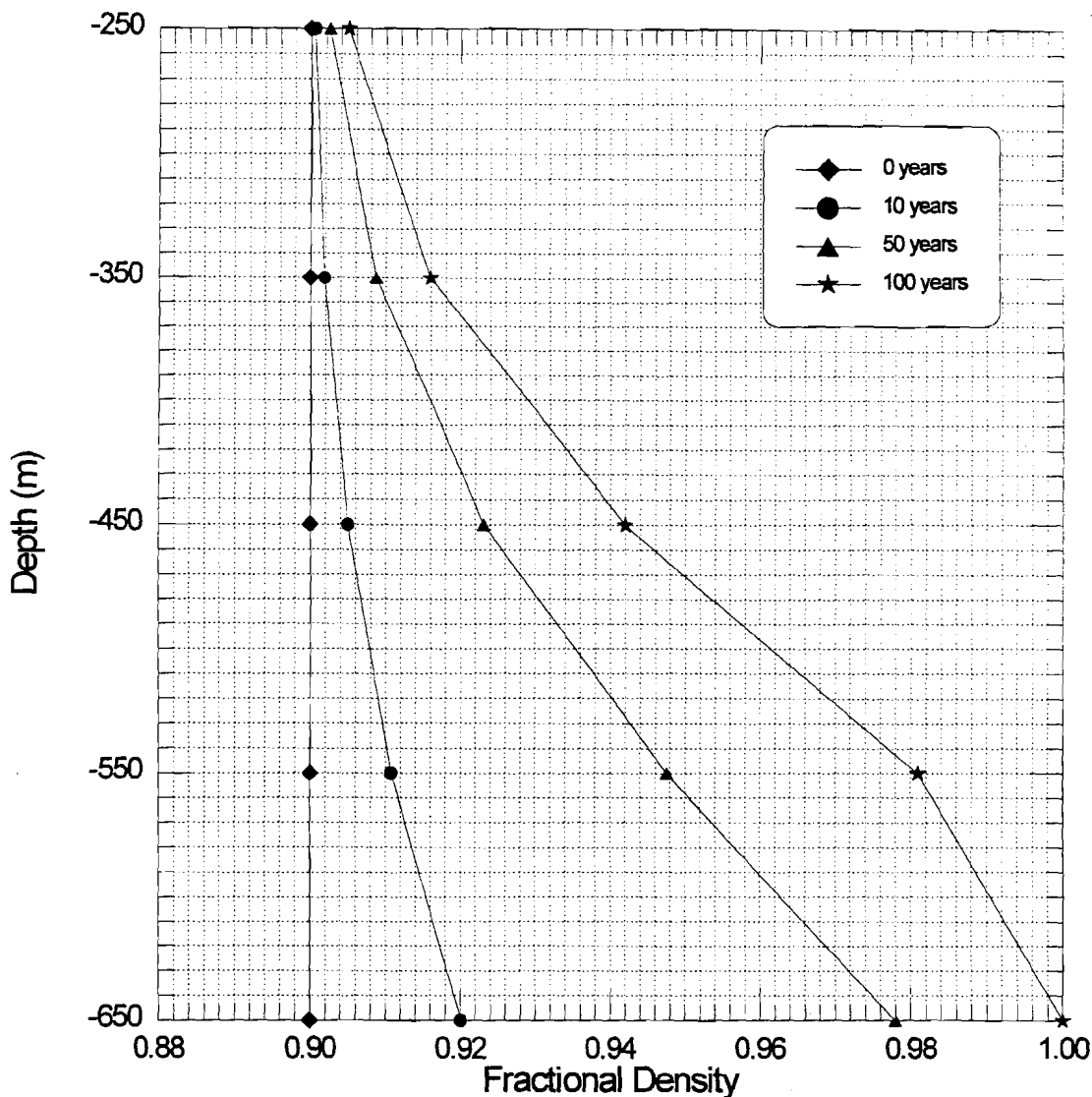

Figure D-3. Fractional density of reconsolidated salt for argillaceous salt.

D.3.3.2 Disturbed Rock Zone (DRZ) Definition

The Salado Formation between the depths of approximately 250 m to 650 m is primarily composed of halite, which exhibits time-dependent deformation. A DRZ develops around an excavation in response to the stress relief provided by the excavation. The extent of the DRZ will be reduced in halite as the salt creeps in on the sealing material creating back stresses on the shaft wall. The extent of the DRZ is a function of the type of halite surrounding the shaft, time, depth, and the stiffness of the sealing material. RE/SPEC, Inc. calculated the radial extent of the DRZ for times 0, 10, 25, 50, and 100 years after seal emplacement. The seal materials

WIPP Sealing System Design Report

considered in the RE/SPEC analysis are asphalt, compacted clay, crushed salt, asphalt concrete, and salt-saturated concrete. Asphalt concrete is not used in the shaft sealing system.

The calculations were performed with the finite-element program SPECTROM-32. The calculations assume that a material model describing salt creep can be defined by the Multi-Deformation, Coupled-Fracture (MDCF) material constitutive model, which provides a continuum description of the response and the associated damage evolution of rock salt. This model gives a measure (i.e., the damage stress) of the shear- and tensile-induced damage. The damage stress measure can be used as an indicator of the potential for damage, although it is not actual damage. These calculations indicate that the initial DRZ may extend as much as 80% of the shaft radius into the surrounding argillaceous salt, or may be nonexistent if the shaft is surrounded by clean salt. The healing of the DRZ is directly related to the stiffness of the material filling the shaft. The stiffer the material, the quicker the DRZ heals. In the Dewey Lake Redbeds and the Rustler Formation, the DRZ is not expected to heal since the rock types found in these formations do not exhibit time-dependent behavior. The assumptions of the analysis are:

- The calculations are based upon finite deformation solutions;
- The stratigraphy of the Salado is considered homogeneous as either a clean or an argillaceous halite;
- The initial stress state prior to excavation is lithostatic;
- Permeability changes in the salt DRZ are conservatively assumed to extend as far as the damage;
- The excavation occurs at -50 years and remains open for 50 years, when the salt seal material is emplaced instantaneously;
- The calculations were performed with a series of pineapple-slice models at depths of 250 m, 350 m, 450 m, 550 m, and 650 m.

Figures D-4 through D-7 show the DRZ extent (expressed as a multiple of the shaft radius) as a function of depth and as a function of backfill material for times 0, 10, 50, and 100 years after closure, respectively. At time zero, the DRZ is independent of backfill. Also at time zero, the asphalt waterstop DRZ radii are considered to be equivalent to the excavation radii plus 0.5 m. After 10 years, the DRZ is considered to have healed against the waterstops, and the DRZ radii will be equal to zero.

WIPP Sealing System Design Report

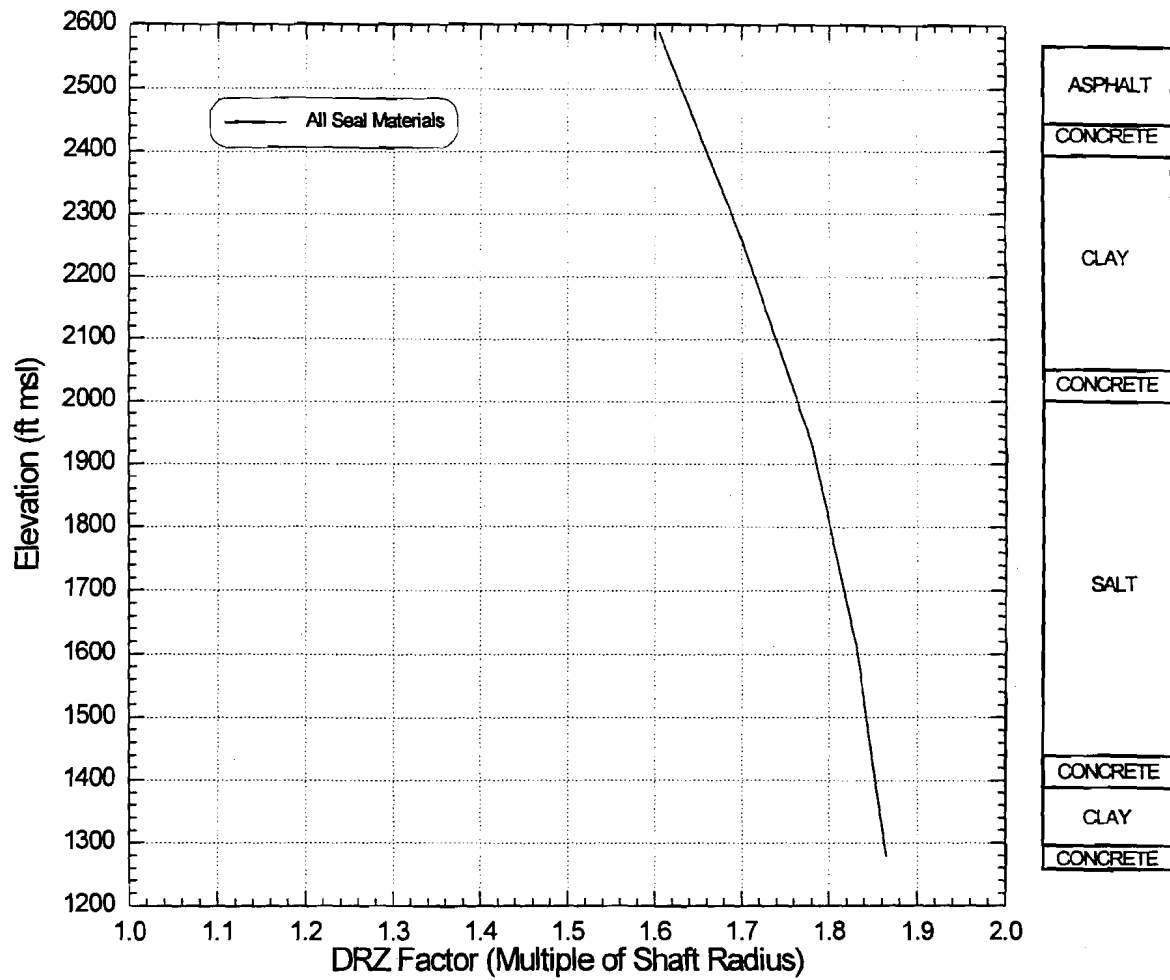

Figure D-4. Maximum DRZ extent at 0 years after closure.

WIPP Sealing System Design Report

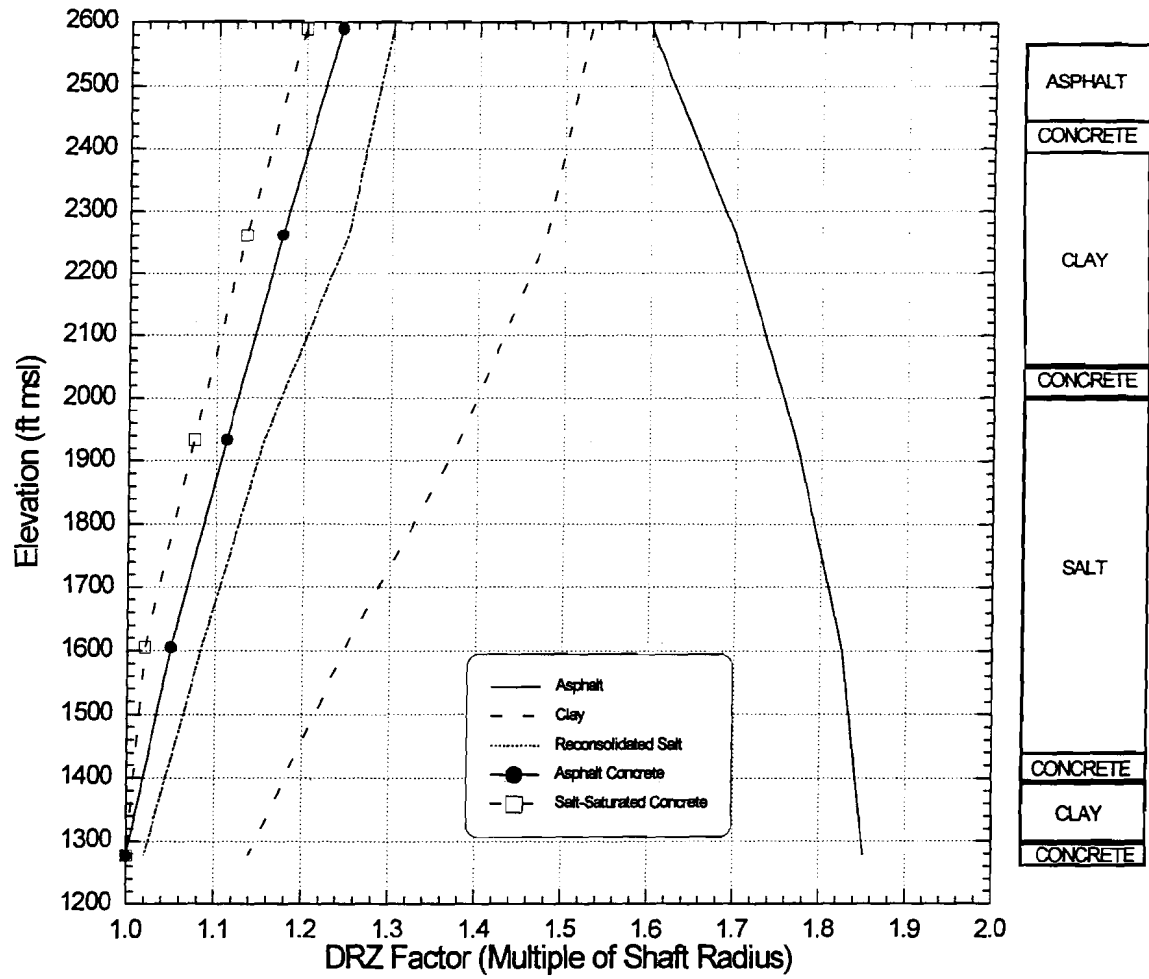

Figure D-5. Maximum DRZ extent at 10 years after closure.

WIPP Sealing System Design Report

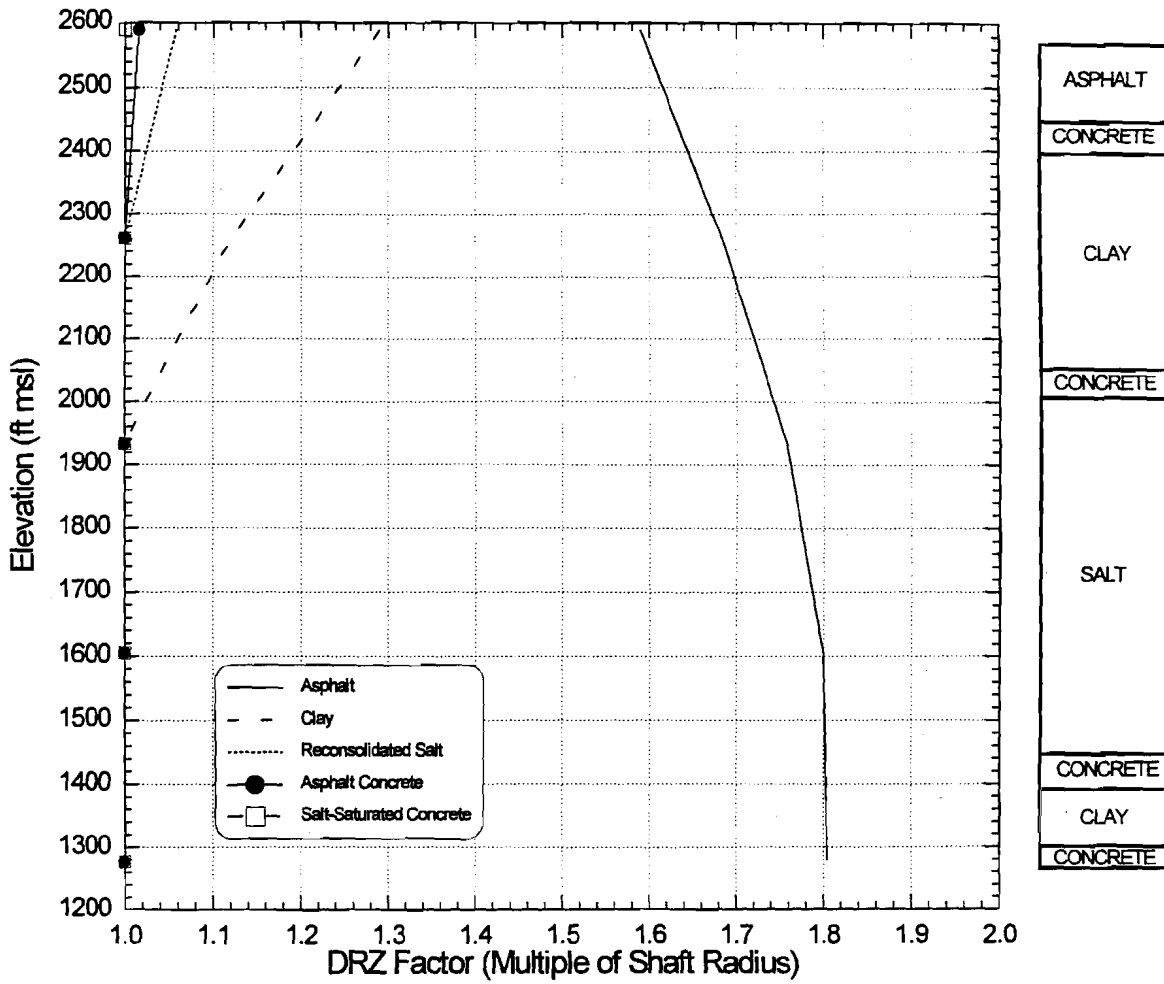

Figure D-6. Maximum DRZ extent at 50 years after closure.

WIPP Sealing System Design Report

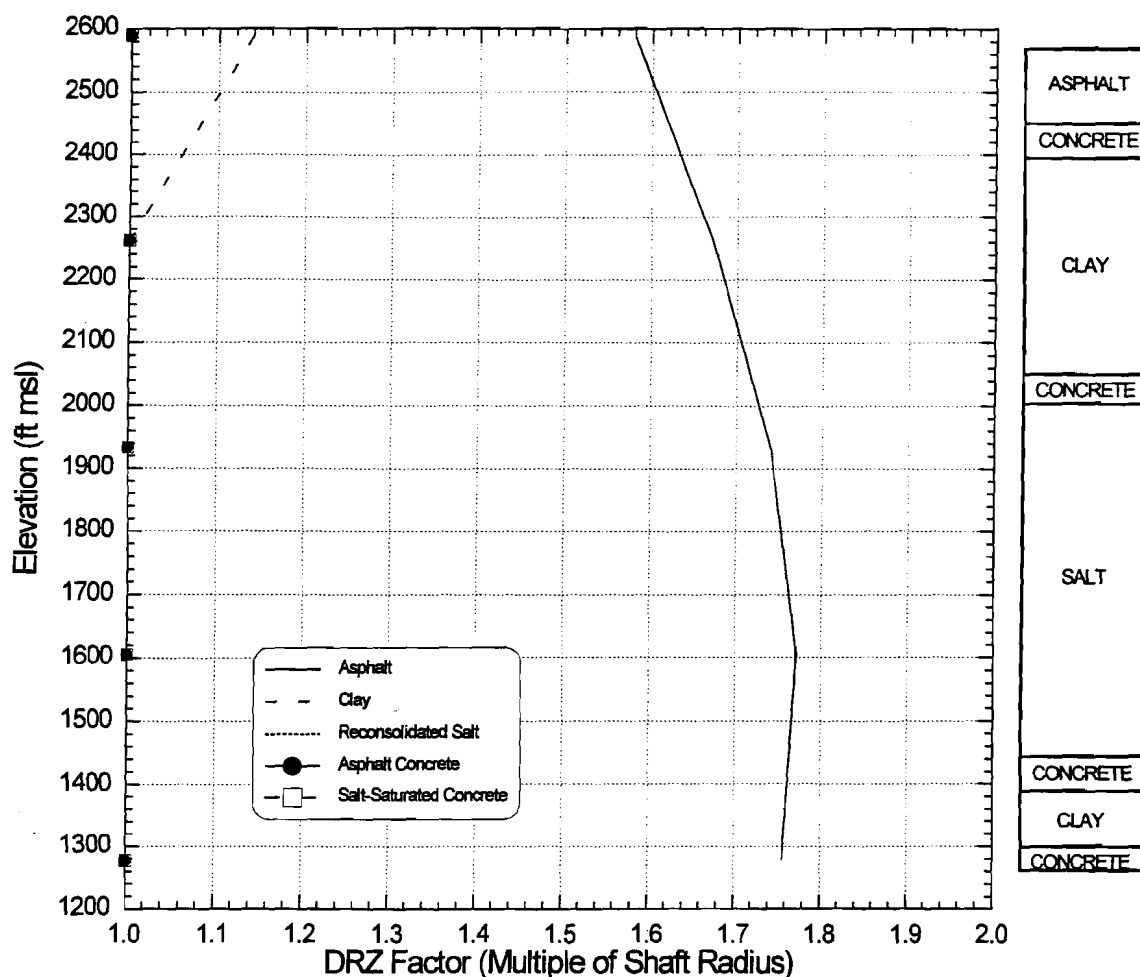

Figure D-7. Maximum DRZ extent at 100 years after closure.

D.3.3.3 Permeability

The permeability (also referred to as the intrinsic permeability) is required for all sealing materials and for the DRZ. The intrinsic permeability of a material is only a property of the pore geometry of a material and, unlike hydraulic conductivity, is not a function of properties of the permeating fluid. The materials and their associated physical properties are described in Section 4 of this report. For a complete listing of the seal material permeabilities, see Table 4-2.

The permeability of the compacted salt column is transient. As the salt consolidates, it

WIPP Sealing System Design Report

increases in density and decreases in permeability. Permeability measurements have been made for several samples of WIPP crushed salt at various fractional densities to describe the relationship between fractional density and permeability (Brodsky, 1994). The fractional density-permeability relationship used in these calculations is the Knowles-Hansen relationship which is shown in Figure D-8. This relationship is linear for argillaceous crushed salt at fractional densities from 0.88 to 1.0. The permeability varies from $1 \times 10^{-11} \text{ m}^2$ at 0.85 to $1 \times 10^{-21} \text{ m}^2$ at 1.0. The relationship is considered conservative in that it would over-predict permeability more often than under-predict permeability of WIPP crushed salt samples.

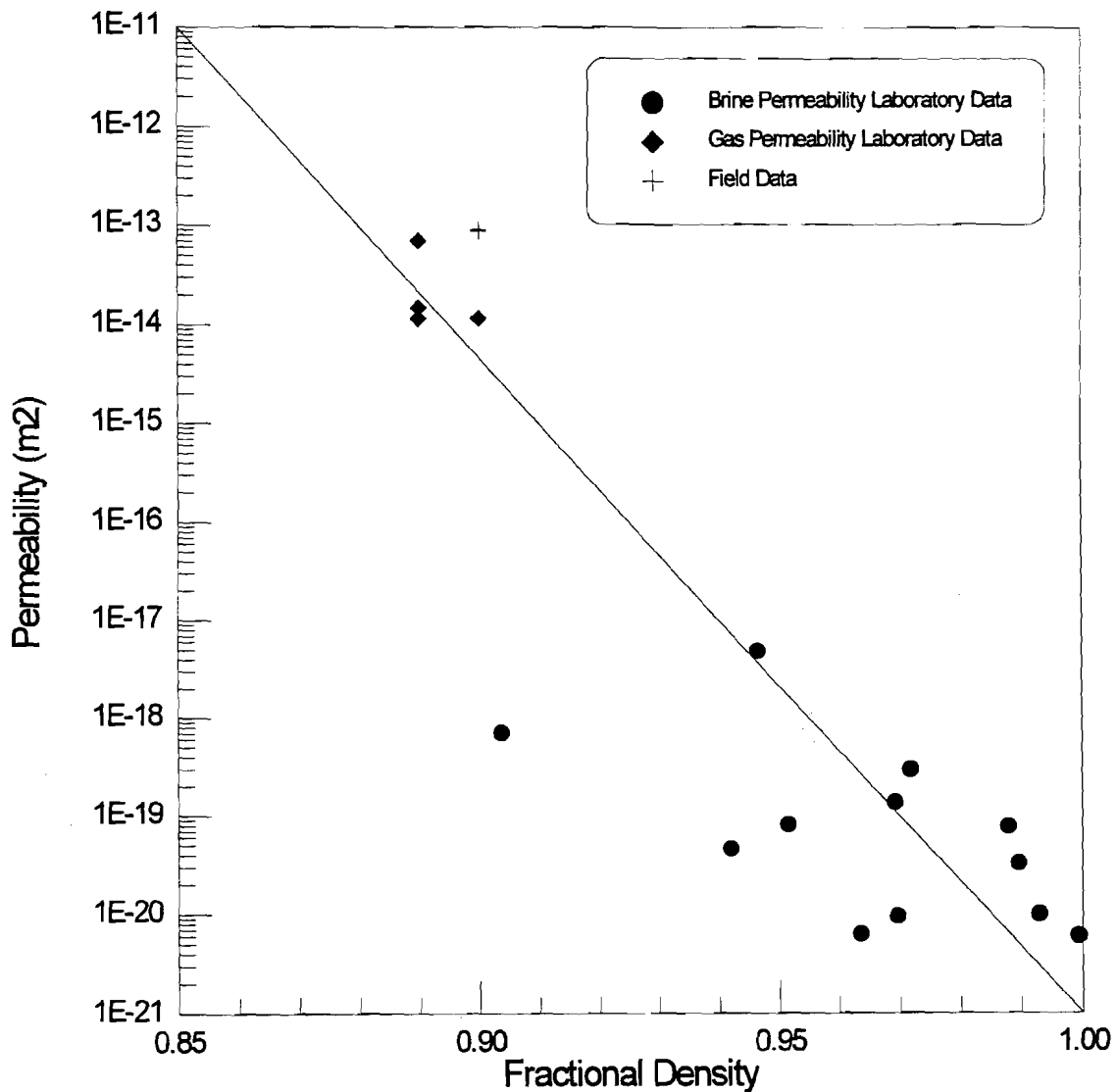

Figure D-8. Knowles-Hansen fractional density versus permeability relationship for WIPP crushed salt.

WIPP Sealing System Design Report

The effective DRZ permeability is estimated from the maximum disturbed permeability and the intact (undisturbed) rock permeability which can be found listed in Table 4-2. The effective DRZ permeability accounts for the decreasing DRZ permeability and the increasing flow area as a function of radius away from the excavation or into the DRZ.

D.4 Comparative Analysis of Seal System Design

The following sections discuss the current seal system design in regards to the design guidance. Because uncertainty is inherent in any engineered system, the design takes advantage of redundancy to minimize overall system uncertainty and to require multiple failure modes. As will be demonstrated, the current seal design offers redundancy in meeting the design guidance for seal hydraulic conductance.

The comparison to the design guidance is discussed in terms of an upper seal and a lower seal consistent with the functional needs of the sealing system. For purposes of this comparative analysis, the upper Salado seal is defined as the seal system between the Rustler-Salado interface and the bottom of the upper Salado compacted clay column. The lower Salado seal is defined as the seal system between the top of the compacted salt column and the bottom of the lower Salado compacted clay column.

D.4.1 Lower Salado Seal Components

The hydraulic conductance for each component comprising the lower seal was calculated. The hydraulic conductance for each component accounts for both the capacity for flow through the cross-sectional seal and the adjacent DRZ (if there is one predicted for the seal material at the time of interest). Table D-1 presents the hydraulic conductance calculated for each seal component comprising the lower seal at 0, 10, 50 and 100 years after closure. Hydraulic conductance is calculated for the cross-sectional seal, the DRZ, and the combination of the two (referred to as the total). In order to make comparisons to the design guidance easier, Table D-1 also contains the hydraulic conductance normalized to the lower seal guidance value of $2.0 \times 10^{-12} \text{ m}^2$. The normalized hydraulic conductance is defined as the guidance hydraulic conductance divided by the calculated hydraulic conductance for the specific seal component. A calculated normalized hydraulic conductance with a value greater than or equal to unity indicates the guidance criteria are satisfied.

After 100 years, it is assumed that the concrete components fully degrade to the permeability of a silt to silty sand ($1 \times 10^{-14} \text{ m}^2$). This is considered a conservative assumption. By 100 years, the compacted salt column has healed to a permeability which provides a hydraulic conductance which by itself meets the lower seal criteria by a factor of 13. From 100 to 10,000 years, the permeability (i.e. hydraulic conductance) of the compacted salt column will continue to decrease approaching an intact salt magnitude. The clay will be stable in the WIPP environment and will maintain its sealing properties throughout the 10,000-year time frame. The asphalt may also be stable in the WIPP environment throughout the regulatory period. However, either the clay or consolidated salt components are sufficient to meet the design guidance.

WIPP Sealing System Design Report

Table D-1. Absolute and Normalized Hydraulic Conductance - Lower Seal Component

Element I	Material Type	Seal Component KA/L (m ² /s)	Normalized Seal Component (KA/L)	DRZ KA/L (m ² /s)	Normalized DRZ KA/L	Total KA/L (m ² /s)	Normalized Total KA/L
TIME = 0 YEARS							
9a	salt-saturated concrete	3.28E-11	0.061	2.50E-09	0.001	2.53E-09	0.001
9b	asphalt	4.26E-13	4.69	1.68E-09	0.001	1.68E-09	0.001
9c	salt-saturated concrete	2.47E-11	0.081	1.90E-09	0.001	1.92E-09	0.001
10	reconsolidated salt	5.19E-09	0.0004	4.62E-11	0.043	5.24E-09	0.0004
11a	salt-saturated concrete	3.28E-11	0.061	2.84E-09	0.001	2.87E-09	0.001
11b	asphalt	4.26E-13	4.69	1.68E-09	0.001	1.68E-09	0.001
11c	salt-saturated concrete	2.47E-11	0.081	2.15E-09	0.001	2.17E-09	0.001
12	compacted clay	7.30E-12	0.274	3.19E-10	0.006	3.26E-10	0.006
TIME = 10 YEARS							
9a	salt-saturated concrete	3.28E-11	0.061	2.99E-10	0.007	3.32E-10	0.006
9b	asphalt	4.26E-13	4.69	---	---	4.26E-13	4.69
9c	salt-saturated concrete	2.47E-11	0.081	2.13E-10	0.009	2.38E-10	0.008
10	reconsolidated salt	1.30E-09	0.0015	5.91E-12	0.339	1.31E-09	0.0015
11a	salt-saturated concrete	3.28E-11	0.061	3.13E-11	0.064	6.41E-11	0.031
11b	asphalt	4.26E-13	4.69	---	---	4.26E-13	4.69
11c	salt-saturated concrete	2.47E-11	0.081	1.18E-11	0.170	3.65E-11	0.055
12	compacted clay	7.30E-12	0.274	5.63E-11	0.036	6.36E-11	0.031
TIME = 50 YEARS							
9a	salt-saturated concrete	3.28E-11	0.061	---	---	3.28E-11	0.061
9b	asphalt	4.26E-13	4.69	---	---	4.26E-13	4.69
9c	salt-saturated concrete	2.47E-11	0.081	---	---	2.47E-11	0.081
10	reconsolidated salt	1.30E-11	0.153	---	---	1.30E-11	0.153
11a	salt-saturated concrete	3.28E-11	0.061	---	---	3.28E-11	0.061
11b	asphalt	4.26E-13	4.69	---	---	4.26E-13	4.69
11c	salt-saturated concrete	2.47E-11	0.081	---	---	2.47E-11	0.081
12	compacted clay	7.30E-12	0.274	---	---	7.30E-12	0.274
TIME = 100 YEARS							
9a	salt-saturated concrete	3.28E-11	0.061	---	---	3.28E-11	0.061
9b	asphalt	4.26E-13	4.69	---	---	4.26E-13	4.69
9c	salt-saturated concrete	2.47E-11	0.081	---	---	2.47E-11	0.081
10	reconsolidated salt	1.77E-13	11.3	---	---	1.77E-13	11.3
11a	salt-saturated concrete	3.28E-11	0.061	---	---	3.28E-11	0.061
11b	asphalt	4.26E-13	4.69	---	---	4.26E-13	4.69
11c	salt-saturated concrete	2.47E-11	0.081	---	---	2.47E-11	0.081
12	compacted clay	7.30E-12	0.274	---	---	7.30E-12	0.274

Note: Design guidance hydraulic conductance is equal to 2.0E-12 m²/s

WIPP Sealing System Design Report

Table D-1. Absolute and Normalized Hydraulic Conductance - Lower Seal Component (concluded)

Element I	Material Type	Seal Component KA/L (m ² /s)	Normalized Seal Component (KA/L)	DRZ KA/L (m ² /s)	Normalized DRZ KA/L	Total KA/L (m ² /s)	Normalized Total KA/L
TIME > 100 YEARS							
9a	salt-saturated concrete	6.57E-07	0	---	---	6.57E-07	0
9b	asphalt	4.26E-13	4.69	---	---	4.26E-13	4.69
9c	salt-saturated concrete	4.95E-07	0	---	---	4.95E-07	0
10	reconsolidated salt	1.77E-13	11.3	---	---	1.77E-13	11.3
11a	salt-saturated concrete	6.57E-07	0	---	---	6.57E-07	0
11b	asphalt	4.26E-13	4.69	---	---	4.26E-13	4.69
11c	salt-saturated concrete	4.95E-07	0	---	---	4.95E-07	0
12	compacted clay	7.30E-12	0.274	---	---	7.30E-12	0.274

Note: Design guidance hydraulic conductance is equal to 2.0E-12 m²/s

D.4.2 Upper Salado Seal Components

The hydraulic conductance for each material comprising the upper seal component was calculated. The hydraulic conductance for each component accounts for both the capacity for flow through the cross-sectional seal and the adjacent DRZ (if there is one predicted for the seal material at the time of interest).

Table D-2 presents the hydraulic conductance calculated for each seal material comprising the upper seal at 0, 10, 50 and 100 years after closure. Hydraulic conductance is calculated for the cross-sectional seal, the DRZ, and the combination of the two. In order to make comparison to the PA guidance easier, Table D-2 also contains the hydraulic conductance normalized to the guidance value of $2.0 \times 10^{-10} \text{ m}^2$.

WIPP Sealing System Design Report

Table D-2. Absolute and Normalized Hydraulic Conductance - Upper Seal Component

Element I	Material Type	Seal Component KA/L (m ² /s)	Normalized Seal Component (KA/L)	DRZ KA/L (m ² /s)	Normalized DRZ KA/L	Total KA/L (m ² /s)	Normalized Total KA/L
TIME = 0 YEARS							
6	asphalt	5.52E-15	36200	1.74E-10	1.15	1.74E-10	1.15
7a	salt-saturated concrete	3.28E-11	6.09	2.14E-09	0.094	2.17E-09	0.092
7b	asphalt	4.26E-13	469	1.68E-09	0.119	1.68E-09	0.119
7c	salt-saturated concrete	2.47E-11	8.088	1.62E-09	0.123	1.65E-09	0.122
8	compacted clay	1.84E-12	109	6.56E-11	3.05	6.75E-11	2.96
TIME = 10 YEARS							
6	asphalt	5.52E-15	36200	1.72E-10	1.16	1.72E-10	1.16
7a	salt-saturated concrete	3.28E-11	6.09	5.38E-10	0.371	5.71E-10	0.350
7b	asphalt	4.26E-13	469	---	---	4.26E-13	469
7c	salt-saturated concrete	2.47E-11	8.09	3.93E-10	0.508	4.18E-10	0.478
8	compacted clay	1.84E-12	109	4.27E-11	4.69	4.45E-11	4.49
TIME = 50 YEARS							
6	asphalt	5.52E-15	36200	1.69E-10	1.18	1.69E-10	1.18
7a	salt-saturated concrete	3.28E-11	6.09	---	---	3.28E-11	6.09
7b	asphalt	4.26E-13	469	---	---	4.26E-13	469
7c	salt-saturated concrete	2.47E-11	8.09	---	---	2.47E-11	8.09
8	compacted clay	1.84E-12	109	9.71E-12	20.6	1.16E-11	17.3
TIME = 100 YEARS							
6	asphalt	5.52E-15	36200	1.69E-10	1.18	1.69E-10	1.18
7a	salt-saturated concrete	3.28E-11	6.09	---	---	3.28E-11	6.09
7b	asphalt	4.26E-13	469	---	---	4.26E-13	469
7c	salt-saturated concrete	2.47E-11	8.09	---	---	2.47E-11	8.09
8	compacted clay	1.84E-12	109	9.71E-12	20.6	1.16E-11	17.3
TIME > 100 YEARS							
6	asphalt	5.52E-15	36200	1.65E-10	1.21	1.65E-10	1.21
7a	salt-saturated concrete	6.57E-07	0	---	---	6.57E-07	0
7b	asphalt	4.26E-13	469	---	---	4.26E-13	469
7c	salt-saturated concrete	4.95E-07	0	---	---	4.95E-07	0
8	compacted clay	1.84E-12	109	---	---	1.84E-12	109

Note: Design guidance hydraulic conductance is equal to 2.0E-10 m²/s

D.5 References

- Brodsky, N.S., 1994. *Hydrostatic and Shear Consolidation Tests With Permeability Measurements on Waste Isolation Pilot Plant Crushed Salt*, SAND93-7058, prepared by RE/SPEC Inc., Rapid City, SD, RSI-0453, for Sandia National Laboratories, Albuquerque, NM.
- Butcher, B.M., and F.T. Mendenhall, 1993. *A Summary of the Models Used for the Mechanical Response of Disposal Rooms in the Waste Isolation Pilot Plant with Regard to Compliance with 40 CFR 191, Subpart B*. SAND92-0427, Sandia National Laboratories, Albuquerque, NM.
- Callahan, G.D., 1993. *Crushed Salt as a Seal Material*, invited presentation to technical meeting on consolidation of salt, prepared by RE/SPEC Inc., Rapid City, SD, for Sandia National Laboratories, Albuquerque, NM, March.
- Callahan, G.D., and K.L. DeVries, 1991. *Analyses of Backfilled Transuranic Waste Storage Rooms*, SAND91-7052, prepared by RE/SPEC Inc., Rapid City, SD, RSI-0384, for Sandia National Laboratories, Albuquerque, NM.
- Davies, P.B., 1991. *Evaluation of the Role of Threshold Pressure in Controlling Flow of Waste-Generated Gas into Bedded Salt at the Waste Isolation Pilot Plant*, SAND90-3246, Sandia National Laboratories, Albuquerque, NM, June.
- Munson, D.E., K.L. DeVries, D.M. Schiermeister, W.F. DeYonge, and R.L. Jones, 1992. "Measured and Calculated Closures of Open and Brine Filled Shafts and Deep Vertical Boreholes in Salt," *Proceedings, 33rd U.S. Rock Mechanics Symposium, Santa Fe, NM, June 3-5, 1992*. Eds. J.R. Tillerson and W.R. Wawersik. SAND91-1869. Brookfield, VT: A.A. Balkema. 439-448.
- Munson, D.E., A.F. Fossum, and P.E. Senseny, 1989. *Advances in Resolution of Discrepancies Between Predicted and Measured In Situ WIPP Room Closures*, SAND88-2948, Sandia National Laboratories, Albuquerque, NM, February.
- RE/SPEC Inc., 1995. *Structural Analysis of the Air Intake Shaft Preliminary Seal Design*, Calculation No. 355/11/05, prepared for Sandia National Laboratories, Albuquerque, NM.
- RE/SPEC Inc., 1995a. *Effect of Crushed-Salt Initial Density on WIPP Shaft Seals, Volume 1*, Calculation No. 325/05/04, prepared for Sandia National Laboratories, Albuquerque, NM.

WIPP Sealing System Design Report